

# DISC BRAKE CALIPER TYPES: GMR-S and GMR40-S SPRING APPLIED-AIR RELEASED

## DB 4601

Issue 2

Date: January 86

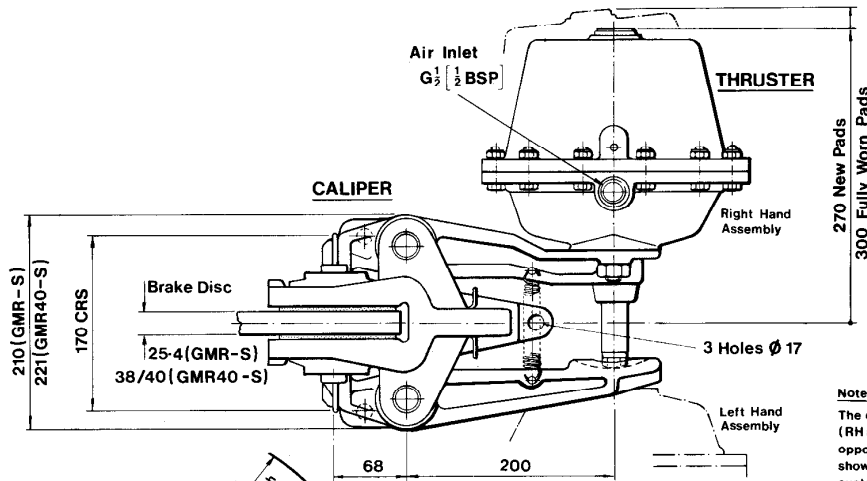

**Note**  
The caliper may be assembled as drawn (RH assembly) or with arms and thruster oppositely handed (LH assembly as shown in broken outline) to suit customer's requirements. Unless otherwise requested, the RH assembly will be supplied.

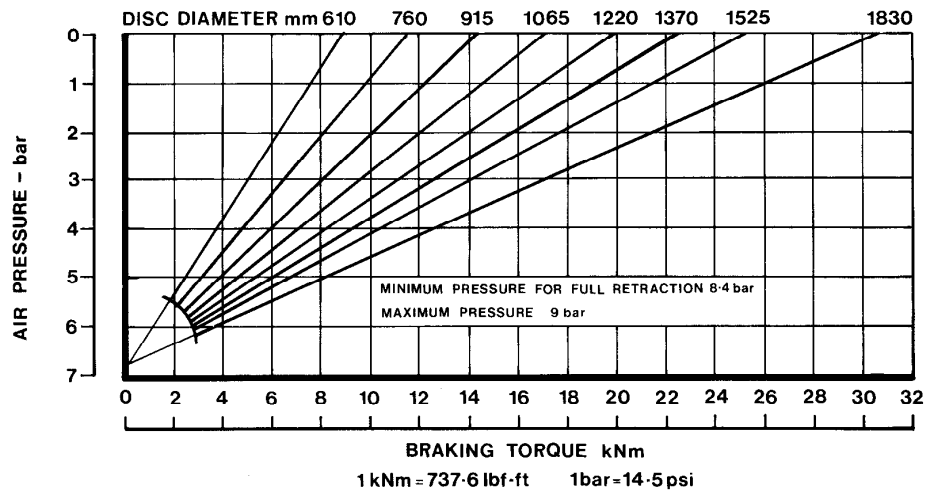
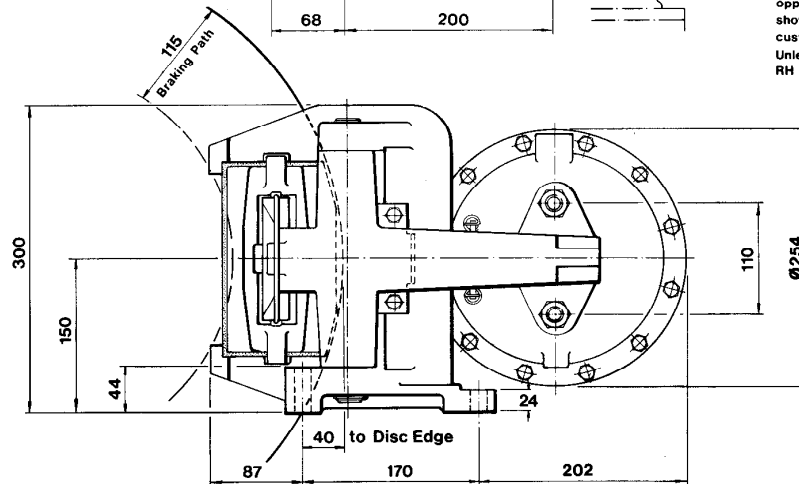

**Brake performance at 36kN braking force (max rating).**  
**Braking Torque (kNm) = Braking Force (kN) × Effective Disc Radius (m) where**  
**effective Disc Radius (m) = Actual Disc Radius (m) - 0.060m**



Distribuidor para España:  
**FU IBERICA, S. L.**

Trafalgar, 4, planta 5  
Telf. 268 18 33 - Fax: 268 32 92  
08010 BARCELONA