

# DISC BRAKE CALIPER: TYPE MUS4

## SPRING APPLIED — AIR RELEASED

Stopping and holding duties.

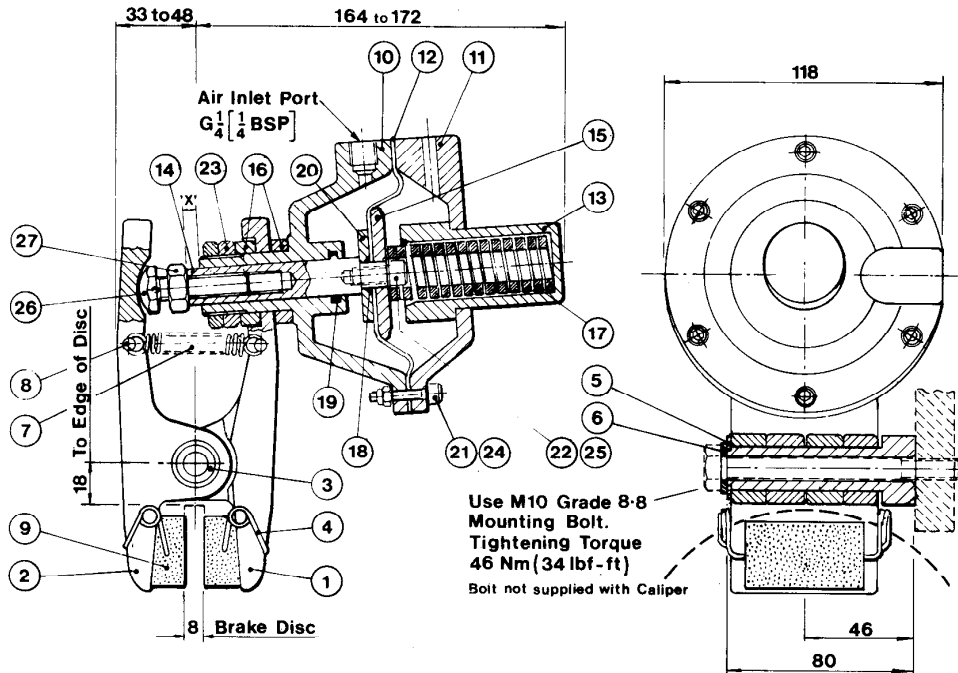

### Disc Brake Caliper Assembly Type MUS4

**Note:** Set dimension 'X' to 8mm with brake 'ON'. This setting corresponds to maximum Braking Force setting. Readjust setscrew (item 26) when dimension 'X' exceeds 10mm. To avoid damage to thruster diaphragm do not turn the Piston Rod while adjusting the setscrew.

### Parts List

Item	Component	Part No.	Qty.
1	Arm (Thruster Side)	6640177	1
2	Arm (Opposite Side)	6640178	1
3	Pivot Post	8240039	1
4	Pad Retaining Spring	2450093	2
5	3/16" Plain Washer	4700209	1
6	M10 Plain Washer	4700208	1
7	Tension Spring	2400109	1
8	Grooved Pin	3100088	2
9	Brake Pad	7080047	2
10	Front Cap	7240934	1
11	Rear Cap	7240935	1
12	Diaphragm	7200936	1
13	Thruster Spring Cap	7250940	1
14	Piston Rod	7250937	1

Item	Component	Part No.	Qty.
15	Piston Rod Plate	7250938	1
16	Spacer	1650494	2
17	Compression Spring	2500191	1
18	O-Ring	6000304	1
19	Quad Seal	6000299	1
20	Pressure Washer	7200976	1
21	M5x25 Skt Hd Cap Screw	5400331	6
22	M8 Light Washer	4700253	1
23	3/4" BSP Nut	5100051	2
24	M5 Nut	5100195	6
25	M8x16 Skt Hd Cap Screw	5400420	1
26	M10x40 Hex Hd Screw	5300268	1
27	M10 Full Nut	5100185	1

### Technical Data MUS4:

Thruster only Part No. 7201127(S4).

Caliper only Part No. 6780918.

Complete assembly

(Caliper and thruster) Part No. 6780924.

Weight (complete assembly) — 2.240kg

Minimum brake disc diameter — 150mm

Disc thickness (Standard) — 8mm

New pad dimensions — 30x50x21mm thick

Brake pad wear allowance — 5mm each pad

Total pad area — 30cm<sup>2</sup>

Minimum pressure for full retraction—6.2 bar (90 psi)

Maximum pressure — 7 bar (100 psi)

**Braking Force** 2600 N (584 lbf) at coefficient of friction  $\mu = 0.38$

Brake torque (Nm) = Braking force (N) x effective disc radius (m).

(Effective disc radius (m) = actual radius (m) — 0.020).



Distribuidor para España:

**"F.U." IBERICA, S.L.**

TRAFALGAR, 4.º B - 08010 BARCELONA

TEL. 93 268 18 33 - FAX 93 268 32 92

Internet: www.fuiberica.com - Email: fuiberica@fuiberica.com