

**DISC BRAKE CALIPER**  
**TYPES: GMR-SH and GMR40-SH**  
**SPRING APPLIED-HYDRAULICALLY RELEASED**

**DB 4600**

Issue 2

Date: Nov. 84

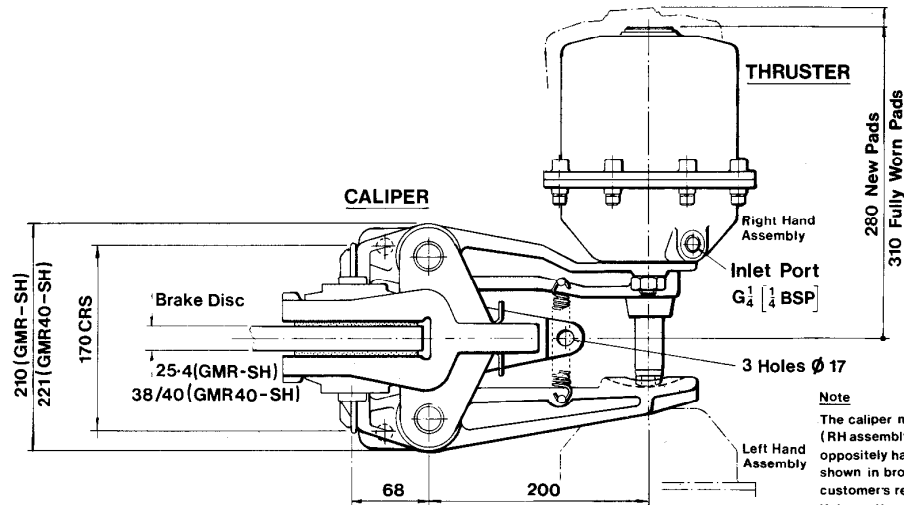

**Note**  
 The caliper may be assembled as drawn (RH assembly) or with arms and thruster oppositely handed (LH assembly as shown in broken outline) to suit customer's requirements. Unless otherwise requested, the RH assembly will be supplied.

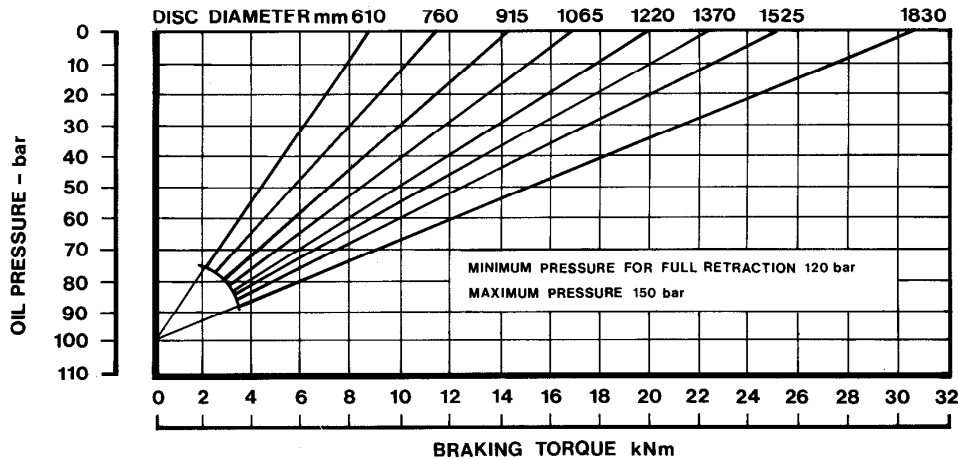
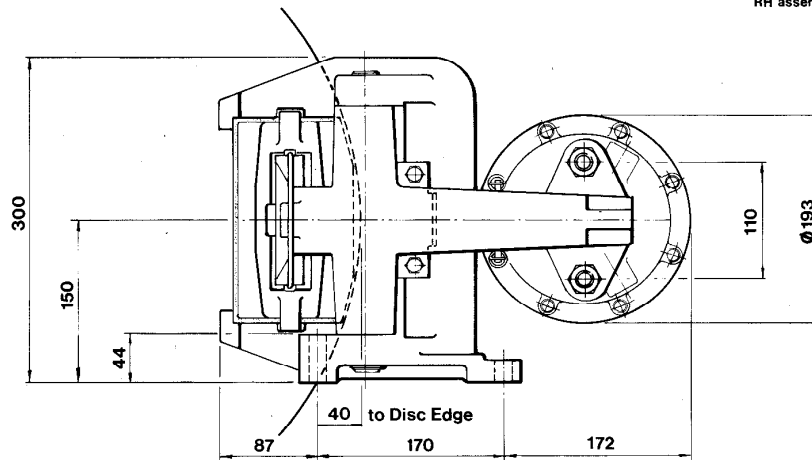

**Brake performance at 35kN braking force (max rating).**



Distribuidor para España:  
**FU IBERICA, S. L.**

Trafalgar, 4, planta 5  
 Telf. 268 18 33 - Fax: 268 32 92  
 08010 BARCELONA