

DISC BRAKE CALIPER TYPE: MRL
SPRING APPLIED – HYDRAULICALLY RELEASED

DB 4059

Issue 4

Date: October 1987

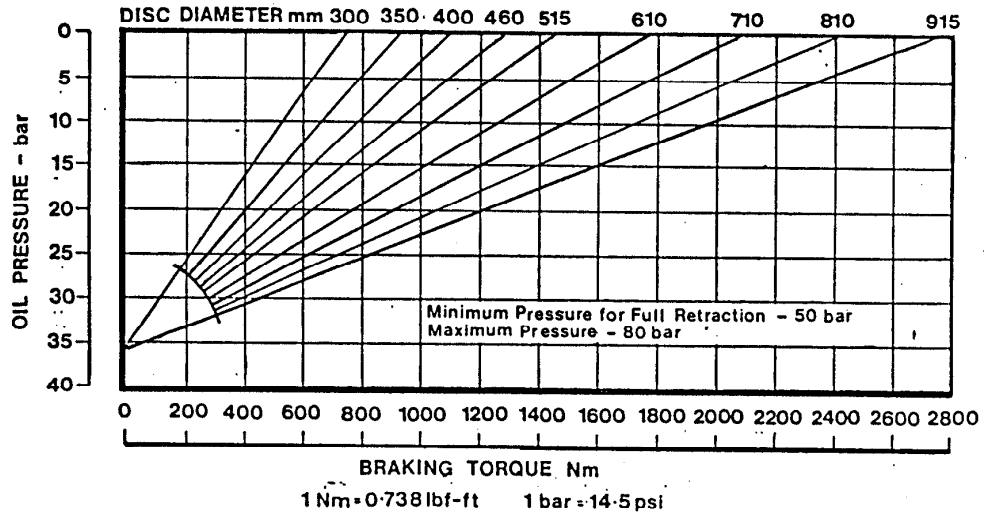
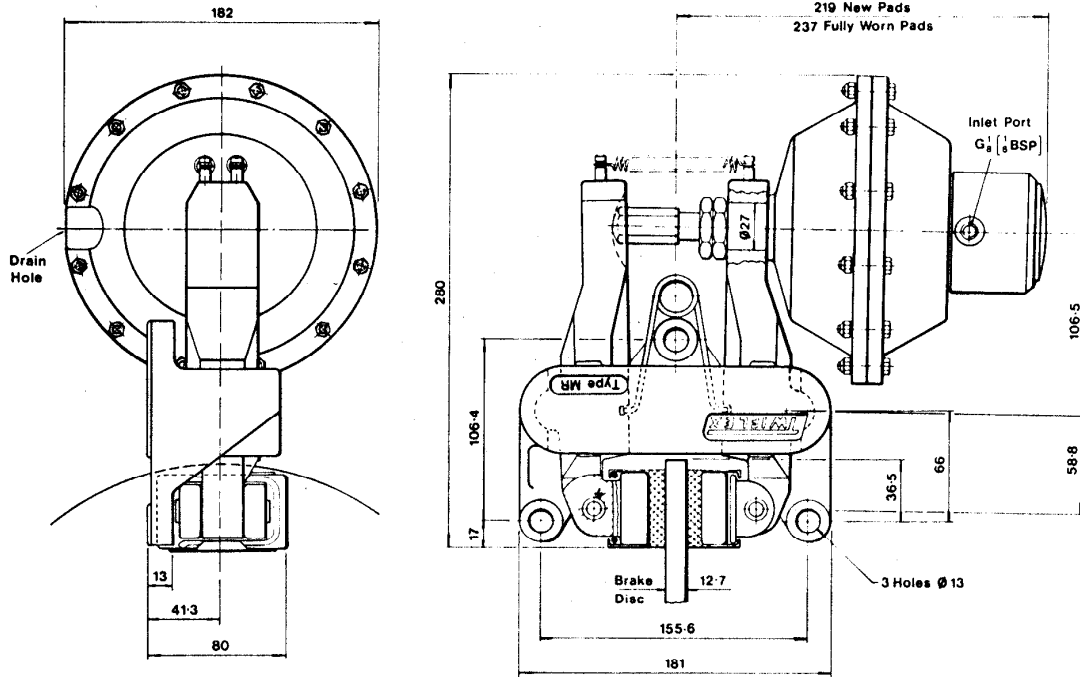

Brake performance at 6.4 kN Braking Force (max rating).

The ratings shown on the above graph are based on fully bedded and conditioned brake pads.

Lower rating calipers are available – see page 3.

- Caliper constructed from SG iron BS 2789.
- Thruster constructed from aluminium alloy to BS 1490.
- Finish – hammer blue paint.
- Weight (caliper and thruster) – 10.2 Kg.
- Weight (caliper only) – 6.2 Kg.
- Total pad area – 58cm².
- Volume displacement of thruster at 4mm stroke = 5ml.

"FU" IBERICA, S.L.