

GMXH Disc Brake Caliper - Mechanically applied Lever operated

Nominal diamensions given
For caliper diamensions see DS2600

DS2606

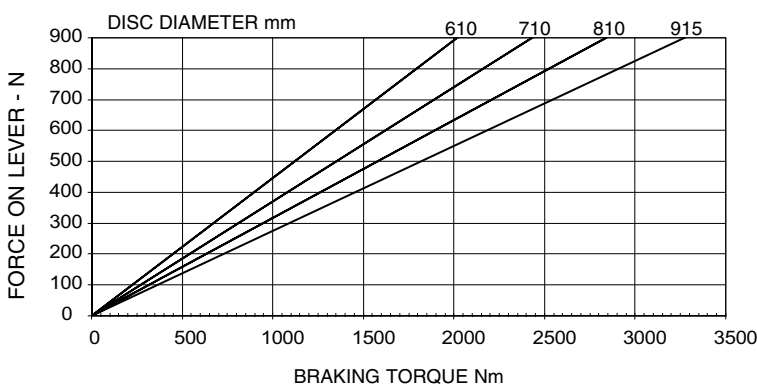
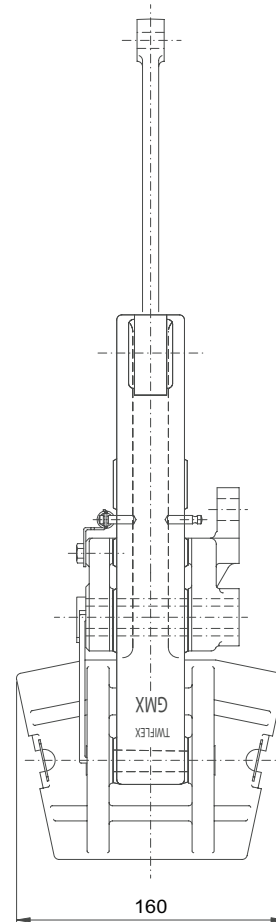
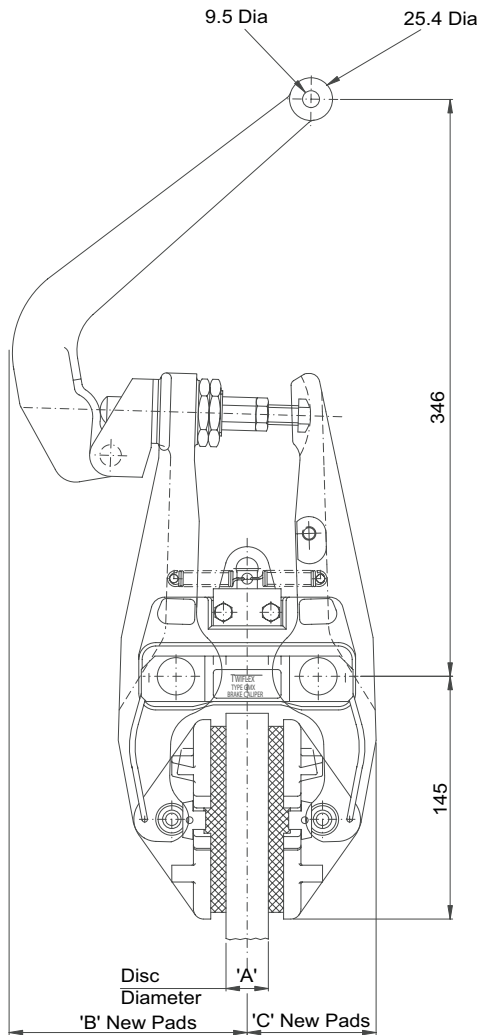

Caliper	Dimensions in mm		
	A	B	C
GMXH 25	25	166	76
GMXH 30	30	167.5	77.5
GMXH 40	40	171	81

Weight (caliper and thruster) - 10.62kg
(lever assembly only) - 1.4kg

Maximum Braking Force = 8.3kN @ 0.9kN force on lever

The ratings shown on the above graph are based on fully bedded and conditioned brake pads with nominal friction coefficient $\mu = 0.4$.

For bedding-in and conditioning procedures see Publication M1060.

Braking Force is defined as the Tangential Force acting on the brake disc at the Effective Disc Radius.

Braking Torque (Nm) = Braking Force (N) x Effective Disc Radius (m) where Effective Disc Radius = Actual Disc Radius - 0.06.

Twiflex Disc Brakes must be used with Twiflex asbestos free brake pads. The use of any other brake pads will invalidate the warranty. Twiflex Limited reserves the right to modify or change the design without prior notice.

GMXH Disc Brake Caliper - Mechanically applied Lever operated

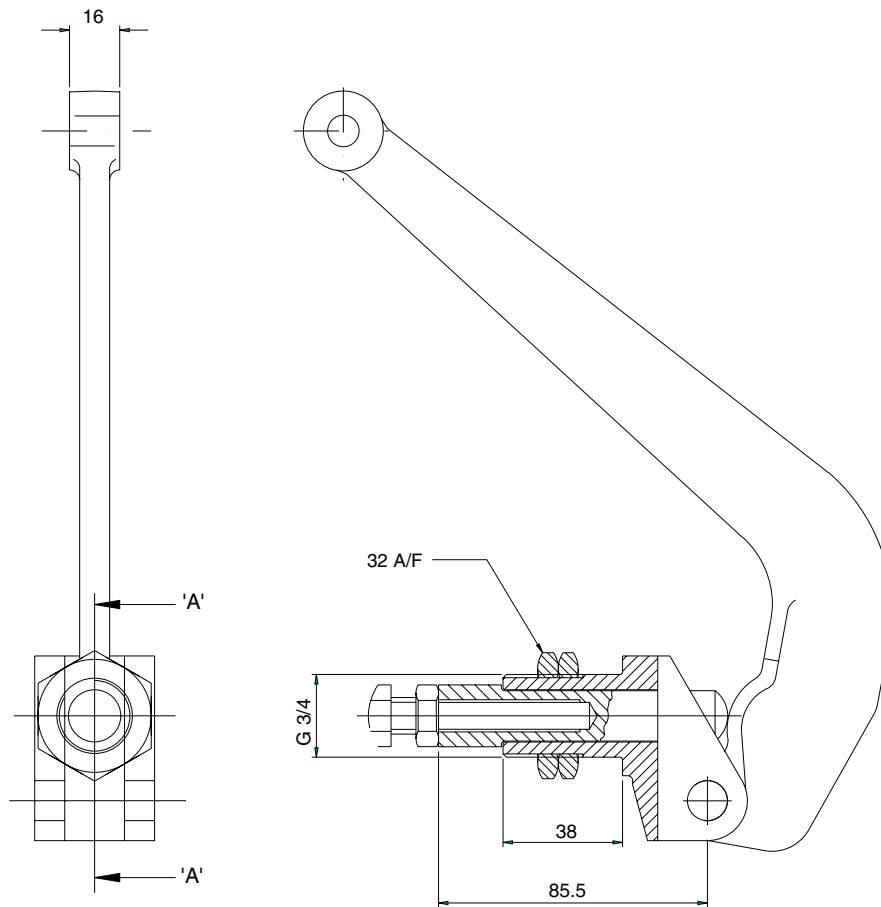

Lever assembly part number 7800125

Thruster fitment

1. Offer thruster to caliper making sure that both lock nuts are removed before placing push rod through caliper arm.
2. Fit lock nuts over the push rod and locate it's end within the slot of the other arm.
3. Tighten one lock nut to 50-60 Nm then tighten the second nut against the first.

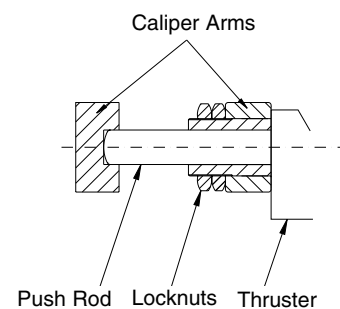

This Approval is in Accordance with Certificate number 850822 Issue 1 Feb 2001 © Twiflex 1998.

Twiflex Limited.

The Green Twickenham
TW2 5AQ England

Tel: 020 8894 1161
Fax: 020 8894 6056
Website: www.twiflex.co.uk
e-mail: sales@twiflex.co.uk