

The Controlflex® series



Standard

For all standard encoders



Impuls Plus

For encoders with maximum accuracy



Compact

The very short design



Industry

For robust industrial encoders

Controlflex®

Controlflex® is the ideal coupling for encoders.

Controlflex® is a compact, electrically-insulating, precise shaft coupling with excellent kinematic properties.

Modular construction makes it possible to realize all possible bore combinations from stock.

Industry

The Controlflex® series, designed for robust industrial encoders with larger shaft diameters up to 40 mm.

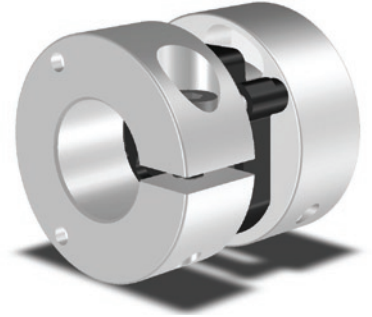
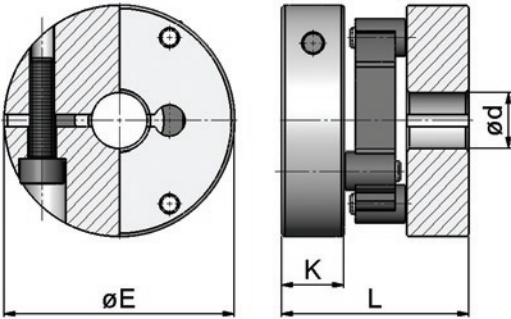

	$\varnothing E$ (mm)	L (mm)	$\varnothing d_{max}$ (mm)	$\varnothing d_{min}$ (mm)	K (mm)	m (kg)	J (kg cm ²)	T_{KN} (Nm)	TK_{max} (Nm)	ΔK_r (mm)	ΔK_w (°)	ΔK_s (mm)	n_{max} (1/min)	C_R (N)
CPS 23.1	56	45	30	8	15	0,2	0,92	7	10	1,5	1,5	1	10.000	6,8
CPS 30.1	75	57	40	10	18	0,43	3,8	15	22	2	1,5	1,5	10.000	10

Order Example 1: CPS 23.1 $\varnothing 12$ $\varnothing 16$ Order Example 2: CPS 30.1 $\varnothing 16$ $\varnothing 20$

CPS 30.1	$\varnothing 16$ $\varnothing 20$
Type Controlflex® Industry CPS 30.1	bore diameters

To ensure the correct selection of the Controlflex® please use our selection procedure and legend area to download the required information.

1. Calculation of the design torque. Please multiply your continuous torque by the required service factor to get the design torque.

service factor

uniform	1
light shocks	1,5
medium shocks	2
heavy shocks	2,5

2. Select a coupling size that has a continuous torque rating greater than your calculated design torque.
3. Make sure that the peak torque of the application does not exceed the maximum torque rating of the coupling.
4. Please check the coupling maximum speed to be sure it is within the rated maximum speed.
5. Make sure that the misalignment capability is sufficient. There is a trade-off between the radial, axial and angular misalignment capabilities. Be certain that the combined percentages of each do not exceed 100%.

Legend

Performance

T_{KN}	continuous torque rating of the coupling (Nm)
T_{Kmax}	maximum torque capacity of the coupling (Nm)
n_{max}	maximum speed of the coupling (1/min)
ΔK_r	maximum radial misalignment capacity (mm)
ΔK_a	maximum axial misalignment capacity (mm)
ΔK_w	maximum angular misalignment capacity (°)
C_R	restoring forces at 0,2 mm radial misalignment (N)
J	moment of inertia (kg cm ²)

Dimension

$\varnothing E$	coupling diameter (mm)
L	coupling length (mm)
K	clamp hub length (mm)
$\varnothing d_{max}$	maximum bore diameter (mm)
$\varnothing d_{min}$	minimum bore diameter (mm)
m	weight of the coupling (kg)