

METRIC BALL SCREW JACKS

With over twenty-five years of experience manufacturing precision worm gear screw jacks, Nook Industries has expanded the ActionJac™ offering to include metric models providing design engineers a globally accepted product. All the efficiency advantages that come with ball screw technology are available in ActionJac™ metric ball screw jacks. A full line of IEC motor mounts are available.

See the technical introduction at the beginning of this section for additional Metric Ball Screw Jack features and comparison to Machine Screw Jacks.



Download Accurate Moveable Assembly 3D Models and 2D Drawings

For ActionJac™ Worm Gear Screw Jacks:

- **Configure** specific requirements for your Worm Gear Screw Jack application in a simple interface, including motor adapter, right angle reducer, bellows boots and limit switch accessories.
- **View** complete assemblies on-line with zoom, pan and rotate capabilities.
- **Download** true assembly models with full range of motion in native AutoCAD®, SolidWorks®, Pro/E®, CATIA®, ParaSolids®, SAT® and many other formats.
- **Order** complete jack assemblies with generated part number.



FU IBERICA, S.L.U.
TRANSMISION DE POTENCIA

Tel. (+34)+34 932 681 833

Fax (+34)+34 932 683 292

<http://www.fuiberica.com>
fuiberica@fuiberica.com



JACK SIZES					JACK SELECTION									
MODEL	Capacity (kN)	Lifting Screw Dia. (mm)	Screw Lead (mm)	Root Dia. (mm)	Gear Ratio	Raise for One Turn of Worm (mm)	Maximum Input Torque (N-m)	Maximum Allowable Input (kW)	Max. Worm Speed at Rated Load (rpm)	Maximum Load at 1425 RPM (kN)	Torque to Raise 1 kN (N-m)	No Load Torque (N-m)	BackDrive Holding Torque (N-m)	Page Ref
EM05-BSJ	5	15.7	5	12.9	5:1	1.00	1.21	0.21	1625	5.0	0.24	0.11	1.0	349
					20:1	0.25	0.51	0.09	1625	5.0	0.10	0.11	0.5	349
EM1-BSJ	10	20.0	5	17.5	5:1	1.00	2.41	0.38	1500	10.0	0.24	0.34	2.0	350
					20:1	0.25	1.14	0.19	1585	10.0	0.11	0.34	1.0	350
EM2.5-BSJ	25	25.0	5	22.5	6:1	0.83	5.05	1.08	2035	25.0	0.20	0.56	4.5	351
					12:1	0.42	3.05	0.65	2035	25.0	0.12	0.56	2.5	351
					24:1	0.21	2.13	0.38	1695	25.0	0.09	0.56	2.0	351
EM5-BSJ	50	40	10	34.8	6:1	1.67	19.3	2.28	1125	39.4	0.39	1.13	16.0	352
					24:1	0.42	7.7	0.56	695	24.4	0.15	1.13	6.5	352
EM10-BSJ	100	50	10	45.2	8:1	1.25	31.9	3.75	1125	78.9	0.32	2.26	26.0	353
					24:1	0.42	16.2	1.12	665	46.6	0.16	2.26	13.5	353
EM20-BSJ	200	63	12	57	8:1	1.50	75.2	5.6	710	99.8	0.38	4.52	61.0	354
					24:1	0.50	37.7	1.9	470	66.1	0.19	4.52	31.0	354

NOTES:

- 1) The recommended maximum speed is 3000 RPM providing that the recommended horsepower and temperature are not exceeded.
- 2) Input torque is shown as torque to lift one kN of load. Starting Torque is 100% greater than torque shown. For loads less than 25% of rated loads add tare drag torque.
- 3) Maximum allowable horsepower ratings are based on a 35% duty cycle. For operation at higher duty cycles or repeated use over any segment of the total travel, temperature must be monitored and remain less than 95°C.
- 4) Overload capacity of the Metric ball Screw Jack is as follows: 0% for dynamic loads, 20% for static loads.
- 5) All Ball Screw Jacks can backdrive and require some means of holding the load, such as a brake on the motor. The product specification pages show holding torque values. Holding torque represents the amount of input torque required to restrain the load and does not indicate recommended brake size to bring dynamic load to stop.
- 6) All units are suitable for intermittent operation providing that the housing temperature including ambient is not lower than -30°C. or higher than +95°C. Factory supplied grease in standard units will operate in this range. For higher or lower operating temperature ranges consult Nook Industries.

- 7) Accessories such as boots, limit switches, top plates and clevises are available.
- 8) Catalog dimensions are representative only and are subject to change without notice. For construction, use only certified prints.
- 9) Units are not to be used as personnel support or movement.
- 10) End-of-travel stops are not provided.

Δ Starting torque is 100% greater than torque shown.

$$\text{kW per jack} = \frac{\text{Torque to raise one kN(N-m)} \times \text{Number of kN to be raised} \times \text{RPM}}{9,549}$$

* No load torque need only be added if operating under 25% rated load.

Column strength is the ability of the lift shaft to hold compressive loads without buckling. With longer screw lengths, column strength may be substantially lower than nominal jack capacity.

If the lift shaft is in tension only, the screw jack travel is limited by the available screw material or by the critical speed of the screw. Refer to the ball screw technical section for critical speed limitations. If there is any possibility for the lift shaft to go into compression, the application should be sized for sufficient column strength.

The chart below is used to determine the required jack size in applications where the lift shaft is loaded in compression.

To use this chart:
Find a point at which the maximum length "L" intersects the maximum load. Be sure the jack selected is above and to the right of that point.

CAUTION: chart does not include a design factor.

The chart assumes proper jack alignment with no bending loads on the screw. Effects from side loading are not included in this chart. Jacks operating horizontally with long lift shafts can experience bending from the weight of the screw. Consult Nook Industries, Inc. if side thrust is anticipated, operating horizontally, or maximum raise is greater than 30 times the screw diameter.

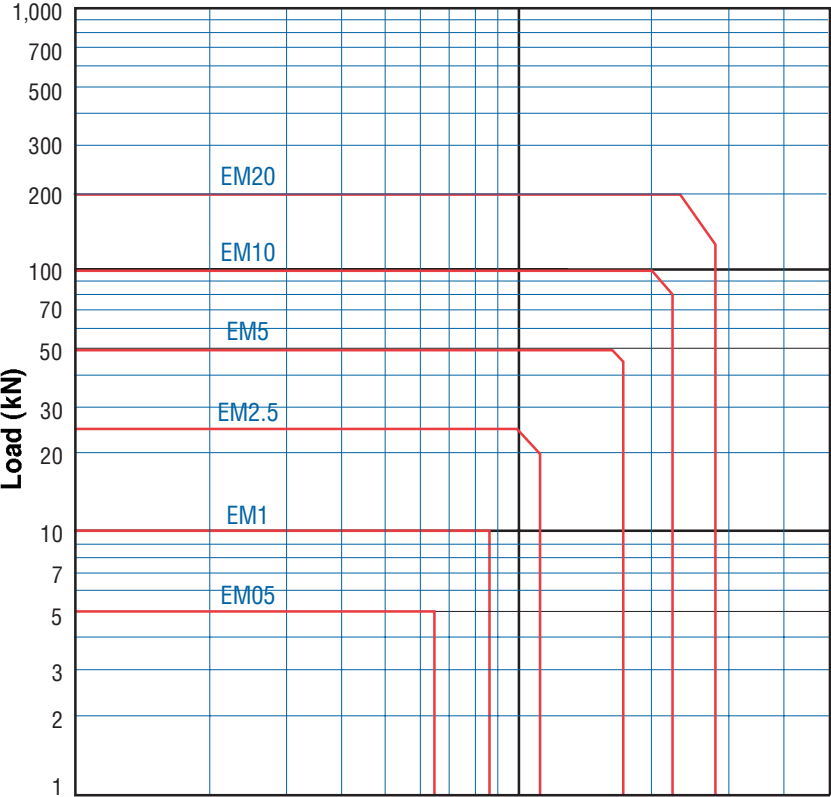

A	50	100	150	250	350	500	1,000	1,500	2,500
B	100	200	200	500	700	1,000	2,000	3,000	5,000
C	150	300	450	750	1,050	1,500	3,000	4,500	7,500
D	200	400	600	1,000	1,400	2,000	4,000	6,000	10,000

"L" (mm)
Metric Ball Screw Jack

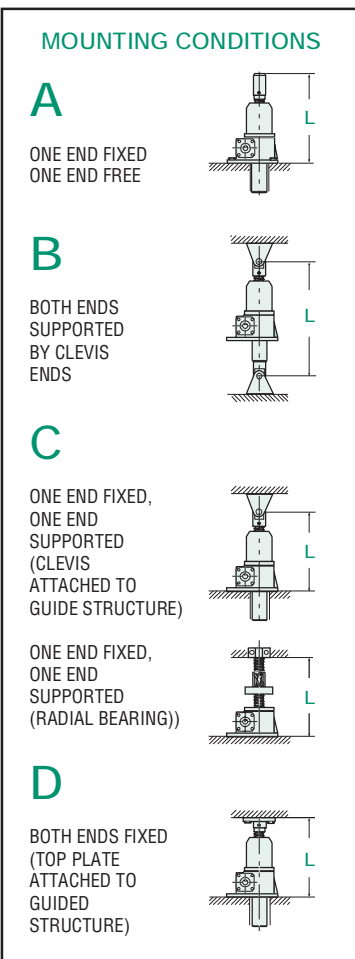

AVAILABLE LIFT SCREW LENGTHS

As a major manufacturer of industrial lead screws, Nook Industries stocks a wide selection of ball screws. Nook Industries has the capacity to make long ball screws for

special applications. Rotating screw jacks can be built with a larger diameter lift screw for greater column strength, or a different lead to change the jack operating speed.

The following Chart provides the minimum life expectancy in total meters of travel for the ball screws.

MODEL	Operating Load (kN)	MINIMUM METERS OF TRAVEL		Page Number
		UPRIGHT & INVERTED	UPRIGHT & INVERTED ROTATING	
		Standard	Standard	
EM05-BSJ	4	34,295	42,869	349
	2	274,360	342,950	
	1	2,194,880	2,743,600	
EM1-BSJ	8	21,455	26,819	350
	5	87,880	109,850	
	2.5	703,040	878,800	
EM2.5-BSJ	22	2,793	3,716	351
	12	18,321	22,901	
	6	146,565	183,206	
EM5-BSJ	44	28,660	35,825	352
	22	229,283	286,604	
	10	2,441,406	3,051,758	
EM10-BSJ	88	6,315	7,894	353
	44	50,522	63,153	
	22	404,178	505,223	
EM20-BSJ	170	6,702	8,378	354
	85	53,618	67,023	
	42	444,444	555,555	

LEAD ACCURACY

The metric rolled thread ball screw, as employed in ActionJac™ products, is held within .1mm per 300 mm cumulative from nominal dimension. Jacks can be matched to within ±.05mm per 300mm when ordered as matched sets. Special ground threads having lead accuracies of .013mm per 300mm can be provided if necessary.

BACKLASH

Axial backlash ranges from .2 to .5 mm. Specify optional selective fit lift shaft for 0.13 to 0.2mm backlash.

MATERIAL HARDNESS

Ball screws have a race hardness of Rockwell C 58 minimum. Core hardness will run from Rc 20 to 35.

NOTES:

- Refer to Lubrication Instructions in order to obtain maximum life from ball screw assemblies
- These values may be greatly reduced if the units are subjected to misalignment, shock loads, side thrust, contamination or lack of proper lubrication and maintenance.

EM2.5-BSJ- U 6:1 / SSE-1 / 80B5-2 / FT / 580mm / SB

BALL SCREW MODEL

kN	Model #	kN	Model #
5	= EM05-BSJ	50	= EM5-BSJ
10	= EM1-BSJ	100	= EM10-BSJ
25	= EM2.5-BSJ	200	= EM20-BSJ

CONFIGURATION

- U = Upright
- I = Inverted
- UR = Upright Rotating
- IR = Inverted Rotating

GEAR RATIO

Refer to product pages for available ratios.

SHAFT ORDER CODE

- CCW Position 1
- CW Position 2

ORDER CODES (Must Include A Position)

NO ACCESSORY

- SSE- = Standard Shaft Extension, Position 1 or 2
- 000- = Delete Shaft Extension, Position 1 or 2
- SPC- = Special Modified Shaft Extension, Position 1 or 2

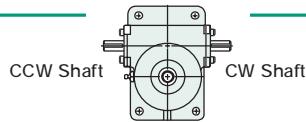

Motor Mounts Without Motor (Position 1 or 2)

56B5 = EM05	80B5 = EM2.5 and EM5
56B14 = EM05	80B14 = EM2.5 and EM5
63B5 = EM1	90B5 = EM5 and EM10
63B14 = EM1	90B14 = EM5 and EM10
71B5 = EM1 and EM2.5	100B5 = EM10 and EM20
71B14 = EM1 and EM2.5	100B14 = EM10 and EM20

NOTE: Both Shaft Extensions Must Be Specified

HOUSING CONFIGURATION

- F = Standard Flange Base

SCREW CONFIGURATION

TRANSLATING - U and I MODELS

- T = Standard Threaded End
- C = Clevis End
- P = Top Plate

ROTATING - UR and IR MODELS

- A = Travel Nut Position "A"
- B = Travel Nut Position "B"

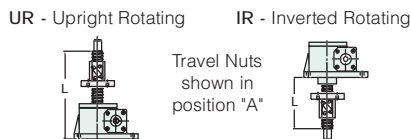

TRAVEL

For Translating Screw Models (U and I) use actual Travel in mm. For Rotating Screw Models (UR and IR) use "L" Dimension in Inches.

MODIFIER LIST

S or M Required

- S = Standard, no additional description required
- M = Modified, additional description required

E and/or B Optional

- E = In-Line Encoder (motor or motor mount required)
- B = Bellows Boots (must calculate retracted and extended boot length, see page 280-281)

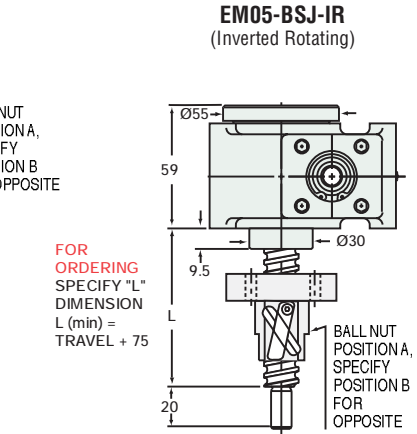
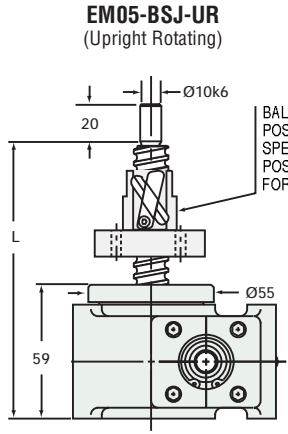
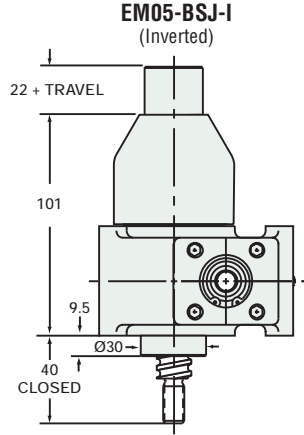
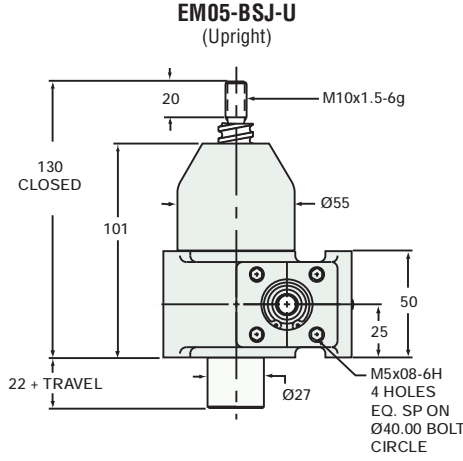
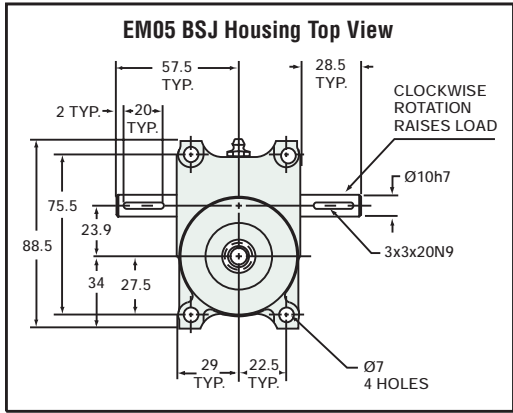

FOR ORDERING SPECIFY "L" DIMENSION L (min) = TRAVEL + 125

FOR ORDERING SPECIFY "L" DIMENSION L (min) = TRAVEL + 75

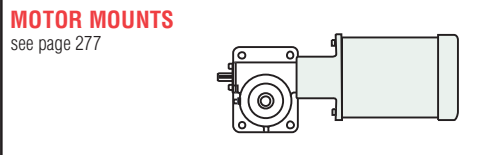
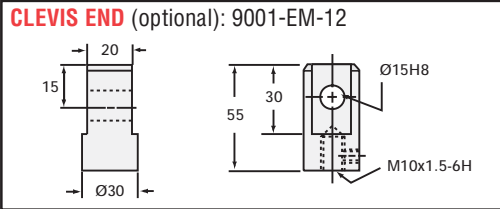
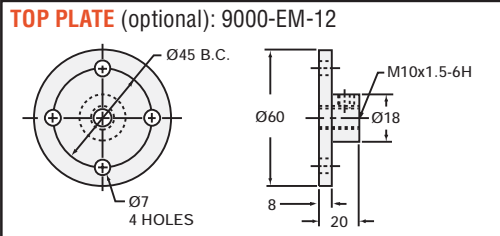

BALL NUT & FLANGE DIMENSIONS

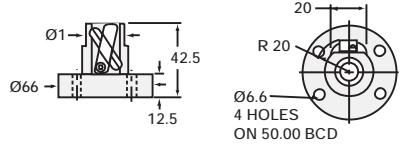

EM05-BSJ SCREW
 SCREW: MRT16x5
 ROOT DIAMETER: 12.9
 DRAG TORQUE: .11
 START TORQUE: 2 x Running Torque
 WEIGHT (Approx. in Kg)
 "0" TRAVEL: 1.36
 PER 100mm TRAVEL: 0.14
 GREASE: 0.14

RATIO	TRAVEL PER 1 TURN OF WORM	TORQUE TO RAISE ONE kN NON-KEYED	MAX. kW	MAX. WORM SPEED AT RATED LOAD NON-KEYED	MAX. LOAD AT 1425 RPM NON-KEYED
5:1	1.00 mm	0.24 Nm	0.21	1625 rpm	5.0 kN
20:1	0.25 mm	0.10 Nm	0.09	1625 rpm	5.0 kN

CAUTION! JACK IS SELF-LOWERING. LIFTING SCREW OR NUT MUST BE SECURED TO PREVENT ROTATION FOR NON-KEYED UNITS.

EM1 BSJ Housing Top View

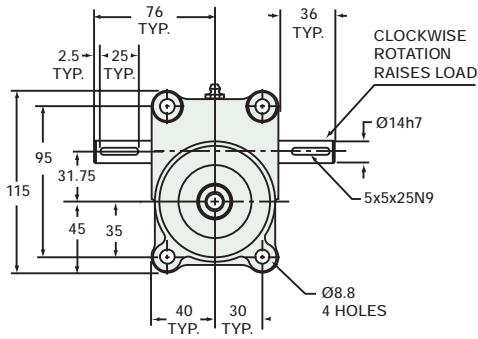

EM1-BSJ-U (Upright)

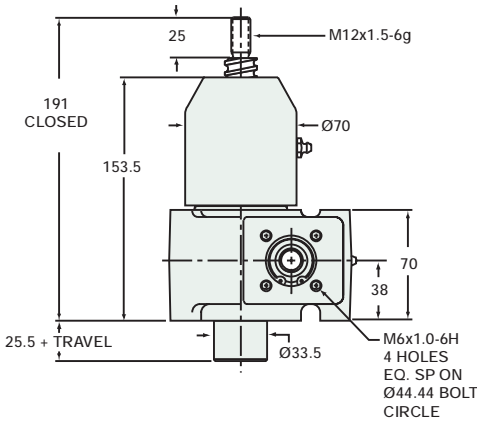

EM1-BSJ-I (Inverted)

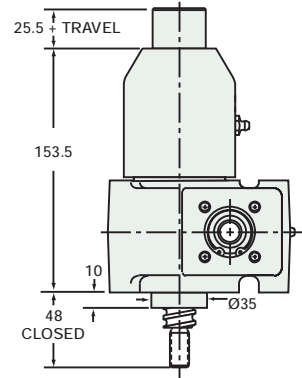

EM1-BSJ-UR (Upright Rotating)

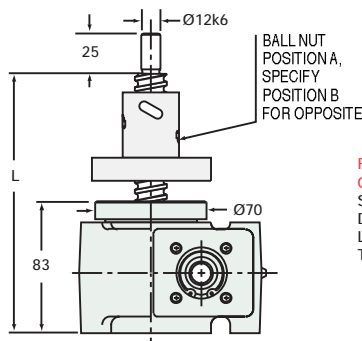

EM1-BSJ-IR (Inverted Rotating)

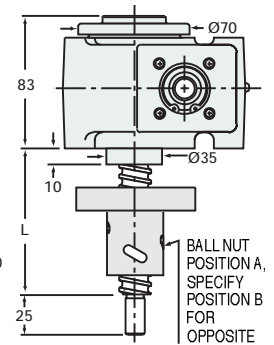

TOP PLATE (optional): 9000-EM-11

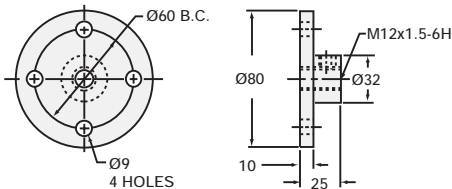

CLEVIS END (optional): 9001-EM-11

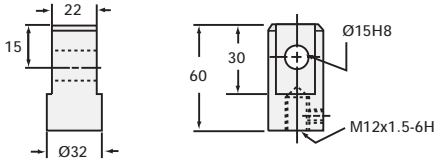

MOTOR MOUNTS

see page 277

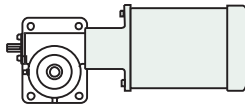

BALL NUT & FLANGE DIMENSIONS

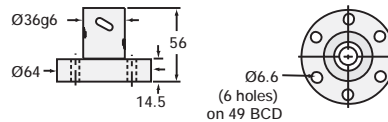

EM1-BSJ SCREW

SCREW:	MRT20x5
ROOT DIAMETER:	17.5
DRAG TORQUE:	0.34
START TORQUE:	2 x Running Torque
WEIGHT (Approx. in Kg)	
"0" TRAVEL:	3.6
PER 100mm TRAVEL:	0.23
GREASE:	0.23

RATIO	TRAVEL PER 1 TURN OF WORM	TORQUE TO RAISE ONE kN NON-KEYED	MAX. kW	MAX. WORM SPEED AT RATED LOAD NON-KEYED	MAX. LOAD AT 1425 RPM NON-KEYED
5:1	1.00 mm	0.24 Nm	0.38	1500 rpm	10.0 kN
20:1	0.25 mm	0.11 Nm	0.19	1585 rpm	10.0 kN

CAUTION! JACK IS SELF-LOWERING. LIFTING SCREW OR NUT MUST BE SECURED TO PREVENT ROTATION FOR NON-KEYED UNITS.

EM2.5 BSJ Housing Top View

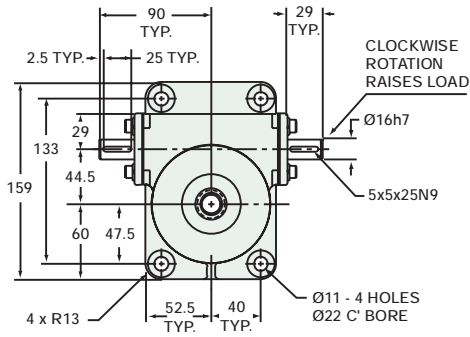

EM2.5-BSJ-U (Upright)

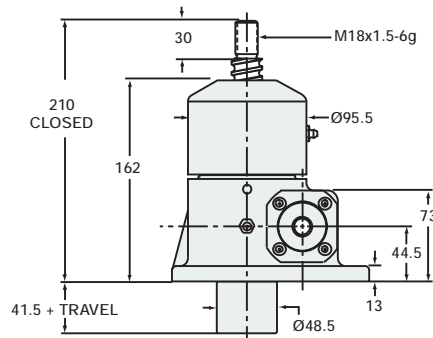

EM2.5-BSJ-I (Inverted)

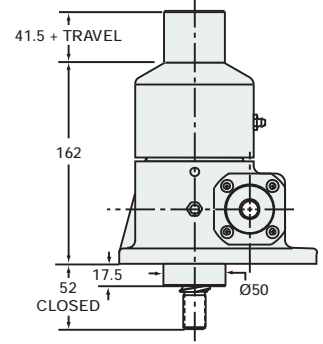

EM2.5-BSJ-UR (Upright Rotating)

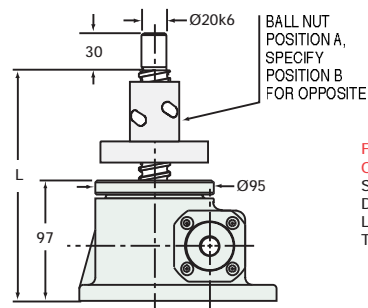

FOR ORDERING SPECIFY "L" DIMENSION
 $L (\text{min}) = \text{TRAVEL} + 186$

EM2.5-BSJ-IR (Inverted Rotating)

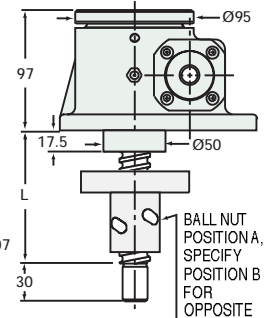

FOR ORDERING SPECIFY "L" DIMENSION
 $L (\text{min}) = \text{TRAVEL} + 107$

TOP PLATE (optional): 9000-EM-01

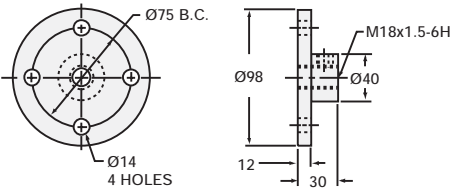

CLEVIS END (optional): 9001-EM-01

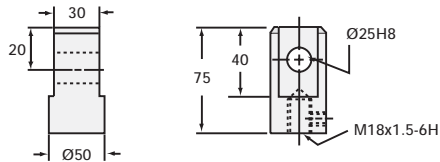

MOTOR MOUNTS

see page 277

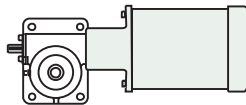

BALL NUT & FLANGE DIMENSIONS

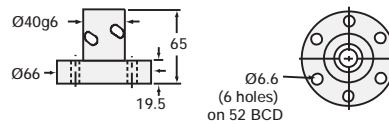

EM2.5-BSJ SCREW

SCREW: MRT25x5
 ROOT DIAMETER: 22.5
 DRAG TORQUE: 0.56
 START TORQUE: 2 x Running Torque
 WEIGHT (Approx. in Kg)
 "O" TRAVEL: 7.7
 PER 100mm TRAVEL: 0.36
 GREASE: 0.22

RATIO	TRAVEL PER 1 TURN OF WORM	TORQUE TO RAISE ONE kN NON-KEYED	MAX. KW	MAX. WORM SPEED AT RATED LOAD NON-KEYED	MAX. LOAD AT 1425 RPM NON-KEYED
6:1	0.83 mm	0.20 Nm	1.08	2035 rpm	25.0 kN
12:1	0.42 mm	0.12 Nm	0.65	2035 rpm	25.0 kN
24:1	0.21 mm	0.09 Nm	0.38	1695 rpm	25.0 kN

CAUTION! JACK IS SELF-LOWERING. LIFTING SCREW OR NUT MUST BE SECURED TO PREVENT ROTATION FOR NON-KEYED UNITS.

EM5 BSJ Housing Top View

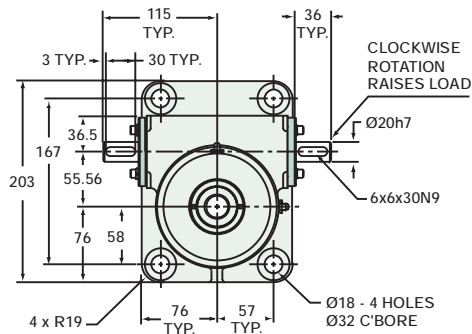

EM5-BSJ-U (Upright)

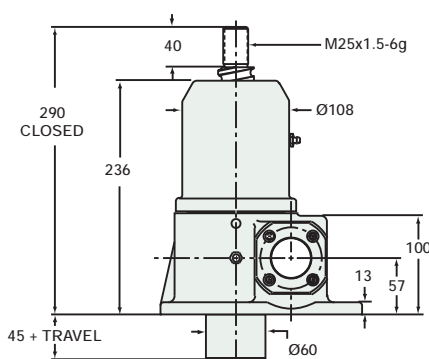

EM5-BSJ-I (Inverted)

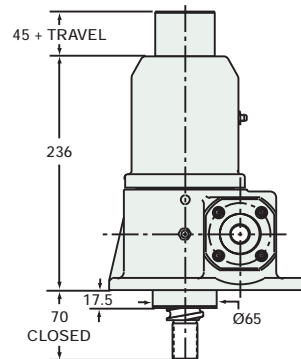

EM5-BSJ-UR (Upright Rotating)

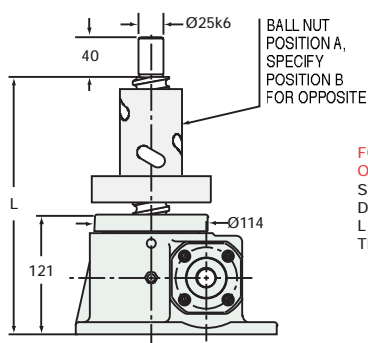

FOR ORDERING SPECIFY "L" DIMENSION
L (min) = TRAVEL + 260

EM5-BSJ-IR (Inverted Rotating)

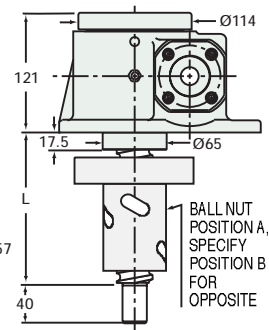

FOR ORDERING SPECIFY "L" DIMENSION
L (min) = TRAVEL + 157

TOP PLATE (optional): 9000-EM-02

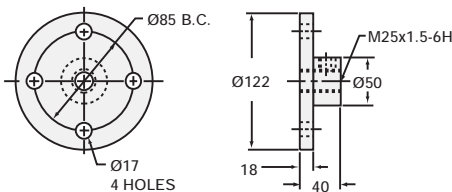

BALL NUT & FLANGE DIMENSIONS

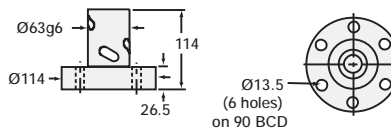

CLEVIS END (optional): 9000-EM-02

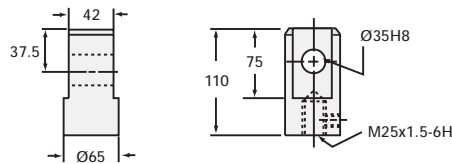

MOTOR MOUNTS

see page 277

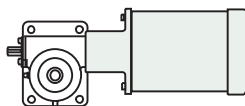

EM5-BSJ SCREW

SCREW:	MRT40x10
ROOT DIAMETER:	34.8
DRAG TORQUE:	1.13
START TORQUE:	2 x Running Torque
WEIGHT (Approx. in Kg)	
"0" TRAVEL:	15.9
PER 100mm TRAVEL:	0.93
GREASE:	0.45

RATIO	TRAVEL PER 1 TURN OF WORM	TORQUE TO RAISE ONE kN NON-KEYED	MAX. kW	MAX. WORM SPEED AT RATED LOAD NON-KEYED	MAX. LOAD AT 1425 RPM NON-KEYED
6:1	1.67 mm	0.39 Nm	2.28	1125 rpm	39.4 kN
24:1	0.42 mm	0.15 Nm	0.56	695 rpm	24.4 kN

CAUTION! JACK IS SELF-LOWERING. LIFTING SCREW OR NUT MUST BE SECURED TO PREVENT ROTATION FOR NON-KEYED UNITS.

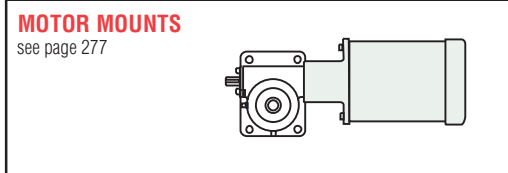
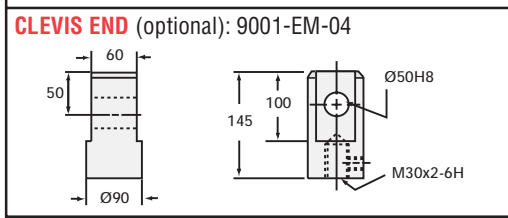
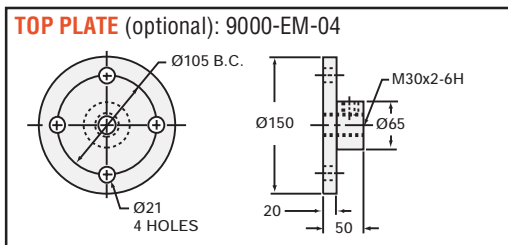
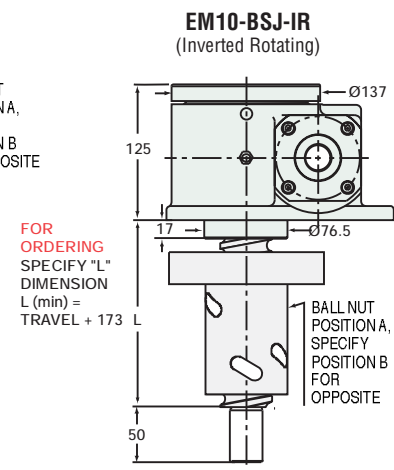
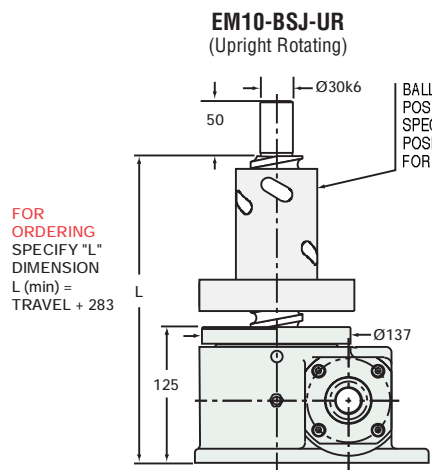
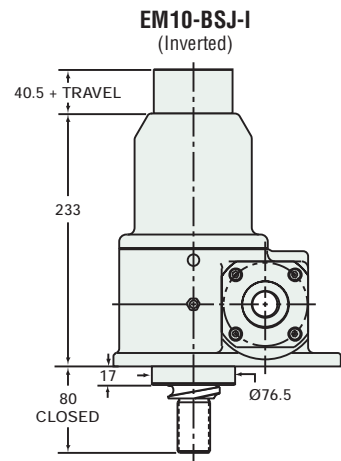
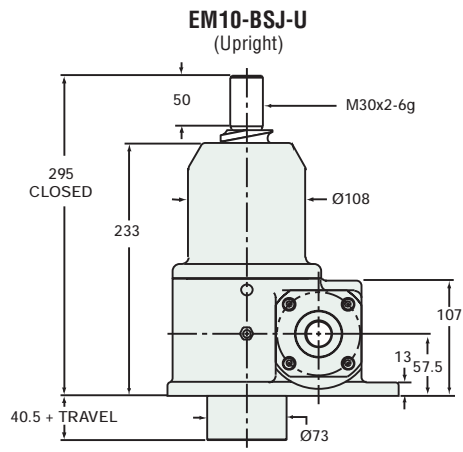
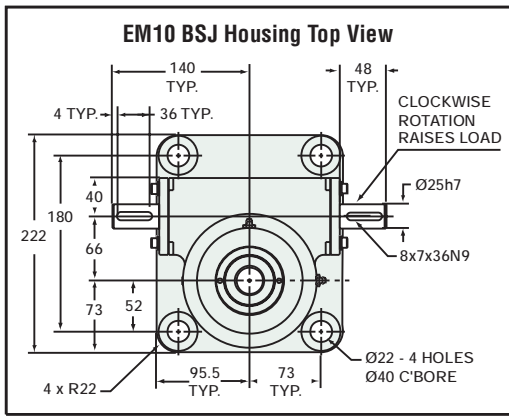

BALL NUT & FLANGE DIMENSIONS

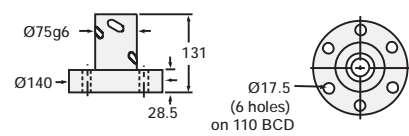

EM10-BSJ SCREW		EM10-BSJ SCREW					
SCREW:	MRT50x10	RATIO	TRAVEL PER 1 TURN OF WORM	TORQUE TO RAISE ONE kN NON-KEYED	MAX. kW	MAX. WORM SPEED AT RATED LOAD NON-KEYED	MAX. LOAD AT 1425 RPM NON-KEYED
ROOT DIAMETER:	45.2	8:1	1.25 mm	0.32 Nm	3.75	1125 rpm	78.9 kN
DRAG TORQUE:	2.26	24:1	0.42 mm	0.16 Nm	1.12	665 rpm	46.6 kN
START TORQUE:	2 x Running Torque						
WEIGHT (Approx. in Kg)							
"D" TRAVEL:	22.7						
PER 100mm TRAVEL:	1.46						
GREASE:	0.68						

CAUTION! JACK IS SELF-LOWERING. LIFTING SCREW OR NUT MUST BE SECURED TO PREVENT ROTATION FOR NON-KEYED UNITS.

EM20 BSJ Housing Top View

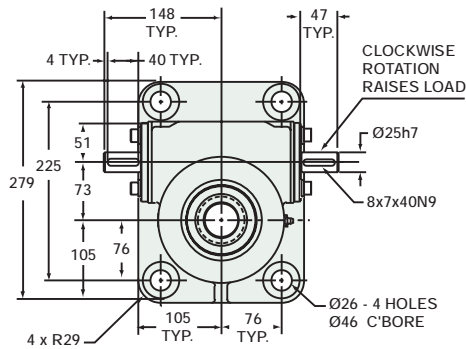

EM20-BSJ-U

(Upright)

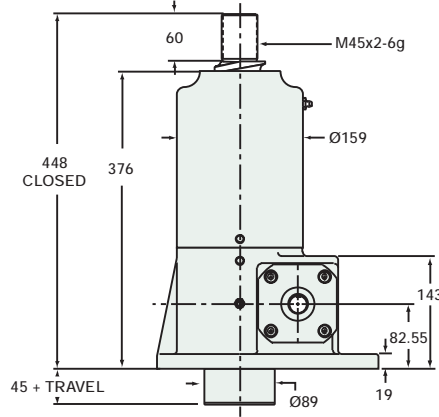

EM20-BSJ-I

(Inverted)

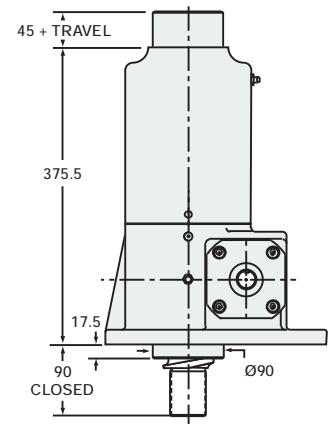

EM20-BSJ-UR

(Upright Rotating)

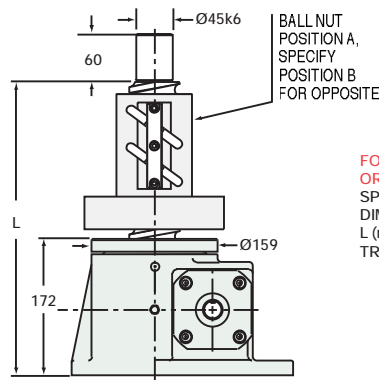

EM20-BSJ-IR

(Inverted Rotating)

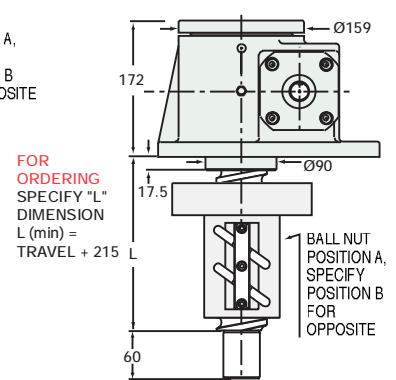

TOP PLATE (optional): 9000-EM-06

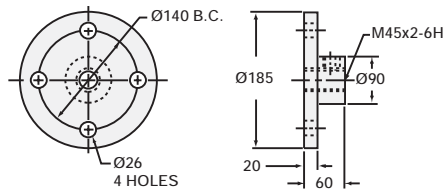

CLEVIS END (optional): 9001-EM-06

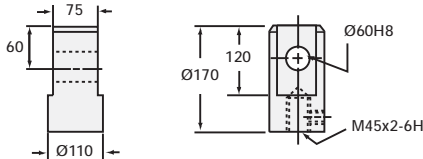

MOTOR MOUNTS

see page 277

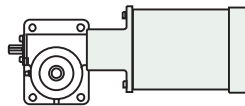

BALL NUT & FLANGE DIMENSIONS

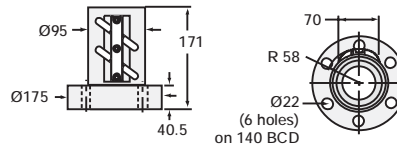

EM20-BSJ SCREW

SCREW: MRT63x12
 ROOT DIAMETER: 57.0
 DRAG TORQUE: 4.52
 START TORQUE: 2 x Running Torque
 WEIGHT (Approx. in Kg)
 "0" TRAVEL: 38.6
 PER 100mm TRAVEL: 2.31
 GREASE: 1.0

RATIO	TRAVEL PER 1 TURN OF WORM	TORQUE TO RAISE ONE kN NON-KEYED	MAX. kW	MAX. WORM SPEED AT RATED LOAD NON-KEYED	MAX. LOAD AT 1425 RPM NON-KEYED
8:1	1.5 mm	0.38 Nm	5.6	710 rpm	99.8 kN
24:1	0.5 mm	0.19 Nm	1.9	470 rpm	66.1 kN

CAUTION! JACK IS SELF-LOWERING. LIFTING SCREW OR NUT MUST BE SECURED TO PREVENT ROTATION FOR NON-KEYED UNITS.