

Eaton Corporation
Airflex Division
9919 Clinton Road
Cleveland, Ohio 44144-1077

Phone (216) 281-2211
Fax: (216) 281-3890

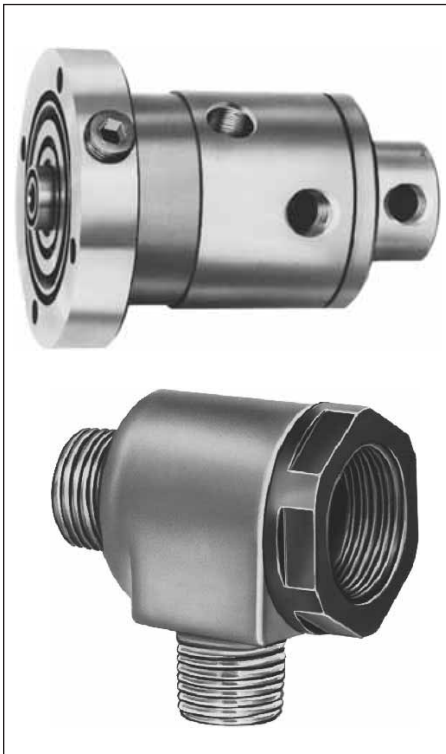

Rotorseals and Quick Release Valves

J

Rotorseals

Description J-1

Single Passage J-2

Dual Passage J-8

Triple Passage J-13

Operating Parameters J-18

Quick Release Valves

Description J-19

Dimensional and Technical Data J-21

Description

The Airflex rotorseal is a rotary union (rotary joint) which permits the transfer of gases or liquids, under pressure or vacuum, into or out of the exposed end of a rotating shaft or body. It was designed primarily for the passage of compressed air or hydraulic fluid to control clutches or brakes. Other applications include the transmittal of cutting fluid to machine tools, lubrication of shaft-mounted components and circulation of water or oil for cooling systems.

The rotating seal is established by a non-metallic sealing ring, held against the rotorseal shaft by a light spring force. The sealing ring is designed so that media pressure acts on both of its ends to minimize the force on the sealing surface.

This design gives positive protection against leakage and compensates for seal wear. Ball bearings are used between the stationary and rotating ports to provide rigidity to the rotorseal assembly and to minimize the running torque.

Rotorseals are available with single, dual and triple passages, in a variety of sizes and designs, to provide the versatility needed to handle most requirements. Single passage rotorseals, in pneumatic installation, can be plumbed with a quick release valve at its inlet port to provide a convenient exhaust.

In most applications, the rotorseal is mounted to the end of a shaft. The shaft is rifle and cross drilled to provide a passageway for the media transmitted. It is important that the rotorseal's axis of rotation be concentric with the rotating member's axis of rotation to minimize rotorseal wobble.

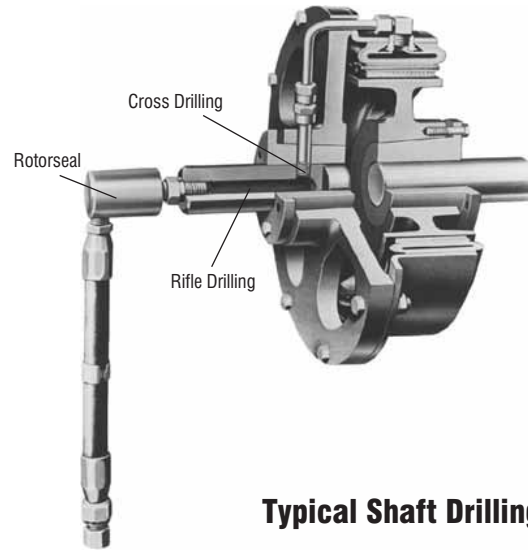

Typical Shaft Drilling

To accommodate eccentricities, a flexible connection must be used between the rotorseal and supply. A rigid connection will tend to preload the rotorseal bearings. The flexible connection should not be installed taut and should include a union and 45° elbow as shown.

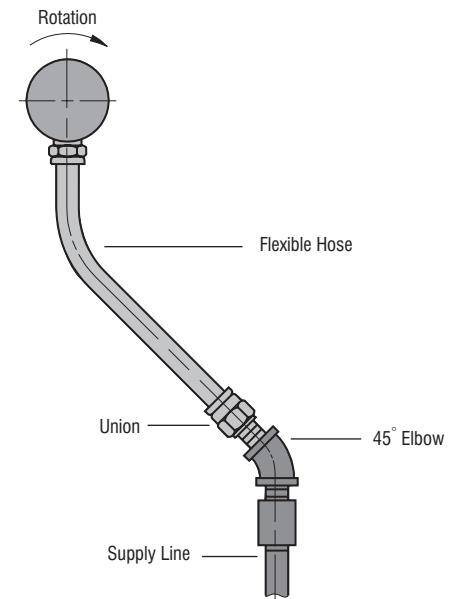
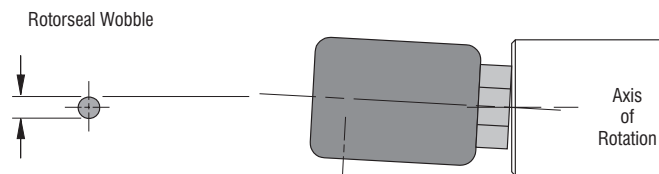

Rotorseal Type	No. of Passages	Inlet Port(s) ❶
AA2	1	1/8-27
B3	1	3/8-18 ❷
C2	1	1/2-14
3/4 RH	1	3/4-14
1 RH	1	1-11 1/2
1 1/4 RH	1	1 1/4-11 1/2
1 1/2 RH	1	1 1/2-11 1/2
2 RH	1	2-11 1/2
AD	2	1/4-18
ADP	2	1/4-18
BD	2	1/4-18
FDA	2	1/2-14
BTA	3	1/2-14

❶ American National Pipe Thread

❷ Furnished with 3/8-18 NPT to 1/4-18 NPT reducer bushing.

The flexible connection should be attached to the rotorseal prior to fastening the rotorseal to the rotating body to avoid seal or bearing damage. The union connection to the supply line is made last.

Component Part Descriptions

Types AA2, B3 and C2

Item	Description
1	Housing
2	Copper Gasket
3	Shaft
4*	Spring
5*	Spring Stop
6*	"O" Ring
7*	Carbon Seal
8	Snap Ring (Internal)
9	Bearing
10	Snap Ring (External)
*	Replacement Seal Kit

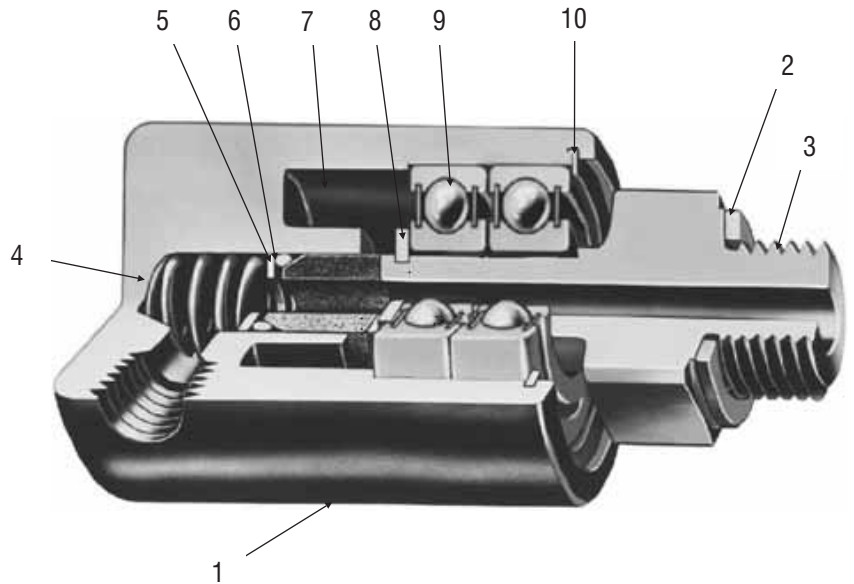

Type RH

Item	Description
1	Housing
2*	Spring
3*	Spring Retainer Washer
4*	"O" Ring
5*	Carbon Seal
6	Shaft
7	Ball Bearings
8	Bearing Spacer
9	Cover
*10	Grommet
*	Replacement Seal Kit

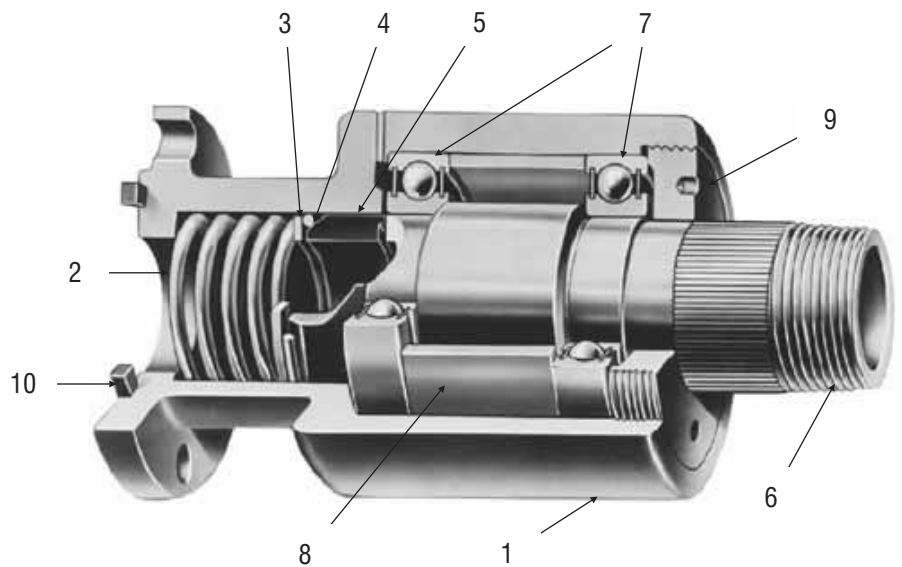

Mounting Dimensions Sizes AA2, B3, & C2

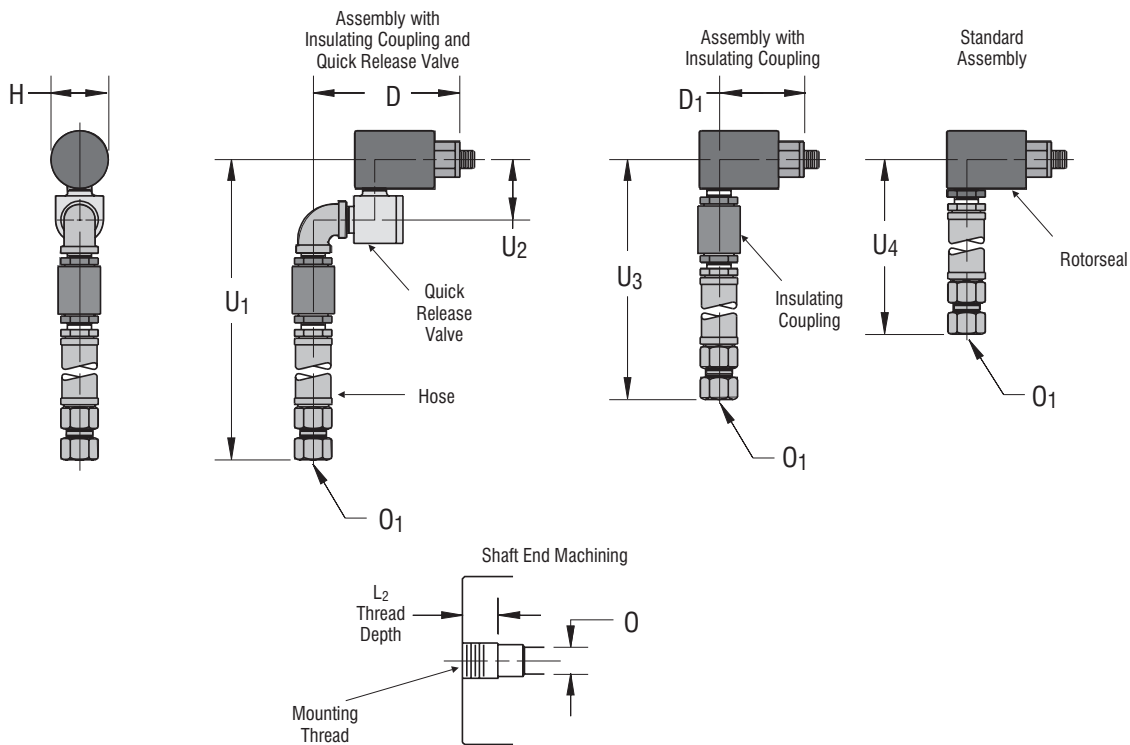

English		Dimensions in inches									
AA2	3/8-24	N/A	2.31	1.38	0.75	0.19	1/8-27	N/A	N/A	N/A	12.5
B3	5/8-18	3.70	2.53	1.63	0.75	0.50	3/8-18	15.3	1.7	14.5	12.5
C2	1-14	4.49	3.15	2.50	1.00	0.75	1/2-14	15.4	2.3	14.2	12.8
Size	Mounting Thread ①	D	D ₁	H	L ₂	O	O ₁ ②	U ₁	U ₂	U ₃	U ₄
AA2	3/8-24	N/A	59	35	19	5	1/8-27	N/A	N/A	N/A	318
B3	5/8-18	94	64	41	19	13	3/8-18	389	43	368	318
C2	1-14	114	80	64	25	19	1/2-14	391	58	361	325
SI		Dimensions in millimeters									

Description	Part Numbers		
	AA2	B3	C2
Rotorseal	145631E	145106BQ	145107BG
Hose used in all arrangements	153x261	318x3	318x2
Insulating coupling ④	N/A	153x263	153x263
Quick release valve	N/A	145406DG	145407DG
Assembly with insulating coupling	N/A	104921	104907
Assembly with insulating coupling & QRV	N/A	104921A	104907A

Notes:

- ① American National Standard for Unified Screw Threads.
- ② American National Pipe Thread.
- ③ Operation at maximum pressure and speed should be avoided. Refer to J-18 for operating parameters.
- ④ Used to prevent the transmittal of stray electrical eddy current.
- ⑤ Furnished with 3/8-18 NPT to 1/4-18 NPT reducer bushing.

Mounting Dimensions Sizes AA2, B3 & C2

Types AA2, B3 AND C2

In most applications, only one fluid is to be transmitted to a rotating assembly. This group of rotorseals will handle most medium volume, single passage requirements. External threads on the seal shaft and standard pipe threads on the inlet port make installations an easy job.

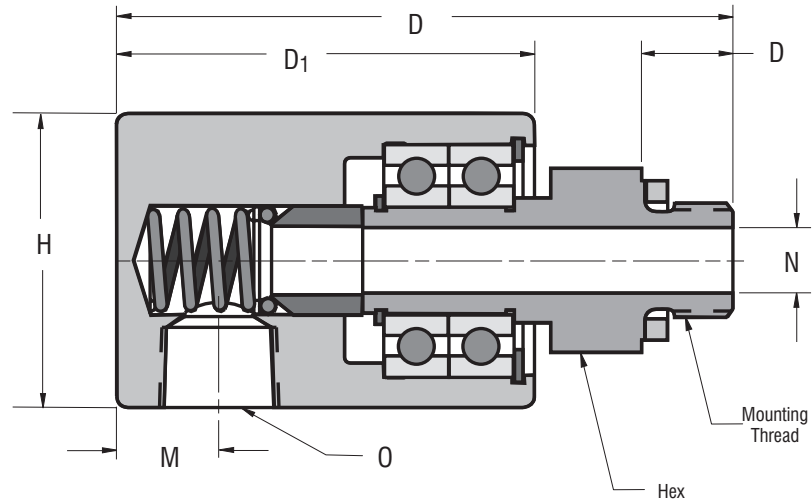

English	in ²	lb	Dimensions in inches								
AA2	0.019	0.4	0.625	3/8-24	2.81	2.00	0.50	1.38	0.38	0.16	1/8-27
B3	0.111	0.6	0.875	5/8-18	3.38	2.29	0.50	1.63	0.56	0.36	3/8-18 ⁵
C2	0.307	2.0	1.375	1-14	4.45	3.06	0.75	2.38	0.69	0.63	1/2-14
Type	Passage Area	Weight Mass	Hex Size	Mounting Thread ¹	D	D ₁	D ₂	H	M	N	O ²
AA2	0,12	0,2	15,9	3/8-24	71	51	13	35	10	4	1/8-27
B3	0,72	0,3	22,2	5/8-18	86	57	13	41	14	9	3/8-18
C2	1,98	0,9	34,9	1-14	113	76	19	60	18	16	1/2-14
SI	cm ²	kg	Dimensions in millimeters								

Type	Description	Part Number	Maximum rpm ³	Maximum Pressure ⁴	
				psi	bar
AA2	Standard model	145631E	4000	150	10,3
	High pressure	145631T	1000	1000	69
B3	Standard model	145106BQ	4000	150	10,3
	High pressure	145106BV	600	1000	69
	With left hand mounting thread	145106BE	4000	150	10,3
C2	Standard model	145107BG	3000	150	10,3
	High pressure	145107BK	400	1000	69
	With left hand mounting thread	145107AQ	3000	150	10,3

Airflex® Single Passage Rotorseals



Form RS 908

Dimensional and Technical Data Type RH

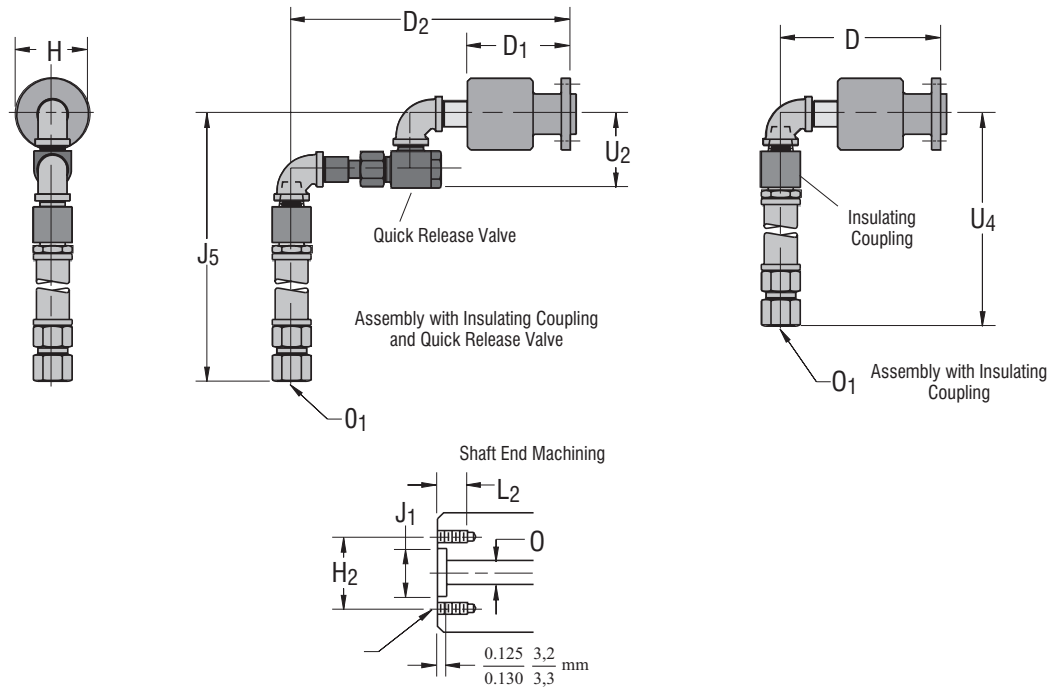

English	Dimensions in inches													
3/4 RH	6.85	4.31	11.94	3.00	2.375	1.750	5/16-18	0.62	0.75	3/4-14	3.75	18.8	21.3	
1 RH	7.50	5.00	12.96	3.25	2.625	2.000	3/8-16	0.75	1.00	1-11 1/2	3.75	19.9	22.8	
1 1/4 RH	8.51	5.50	N/A	3.75	3.125	2.500	3/8-16	0.75	1.25	1 1/4-11 1/2	N/A	27.3	N/A	
1 1/2 RH	9.10	5.63	N/A	4.00	3.375	2.750	3/8-16	0.75	1.50	1 1/2-11 1/2	N/A	33.8	N/A	
2 RH	10.39	6.29	N/A	5.00	4.250	3.500	3/8-16	0.75	2.00	2-11 1/2	N/A	29.1	N/A	
Size	D	D₁	D₂	H	H₂	J₁ ⑤	L ⑥	L₂	O	O₁ ②	U₂	U₄	U₅	
3/4 RH	174	109	303	76	60,3	44,5	5/16-18	16	19	3/4-14	95	478	541	
1 RH	191	127	329	83	66,7	50,8	3/8-16	19	25	1-11 1/2	95	505	579	
1 1/4 RH	216	140	N/A	95	79,4	63,5	3/8-16	19	32	1 1/4-11 1/2	N/A	693	N/A	
1 1/2 RH	231	143	N/A	102	85,7	69,9	3/8-16	19	38	1 1/2-11 1/2	N/A	859	N/A	
2 RH	264	160	N/A	127	108,0	88,9	3/8-16	19	51	2-11 1/2	N/A	739	N/A	
SI	Dimensions in millimeters													

Description	3/4 RH	1 RH	1 1/4 RH	1 1/2 RH	2 RH
Rotorseal	145487K	145488K	145489K	145461K	146175
Hose used in all arrangements	318x4	250x20	250x6	250x7	250x25
Insulating coupling	153x263	153x267	153x265	153x266	153x782
Quick Release Valve	145413BR	145413BR	N/A	N/A	N/A
Assembly with insulating coupling ⑦	104908	104909	104910	105519	N/A
Assembly with insulating coupling & QRV	104908B	104909B	N/A	N/A	N/A

Type RH

For applications which demand a large flow, single passage rotorseal, the RH (rotating housing) type provides a solution. This design incorporates a mounting flange for attachment to the machinery shaft or assembly. External American National Pipe Threads are provided on the rotorseal inlet shaft to facilitate supply line connections.

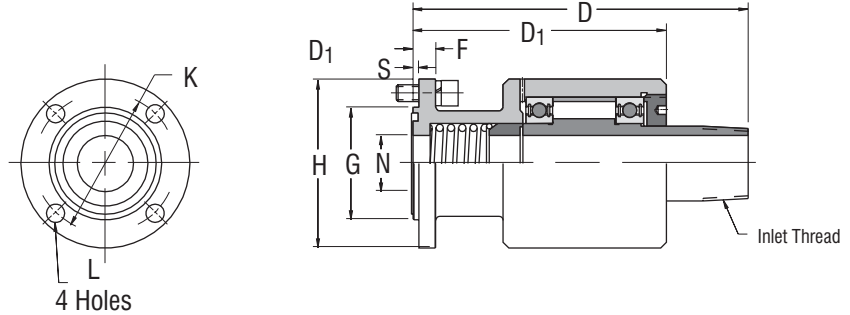

English		in ²	lb	rpm	psi	Dimensions in inches									
3/4 RH	145487K	0.44	3.5	1500	150	3/4-14	6.06	4.44	0.50	1.749	3.00	2.375	0.344	0.75	0.125
1 RH	145488K	0.79	4.5	1200	150	1-11 1/2	6.63	5.13	0.50	1.999	3.25	2.625	0.406	1.00	0.125
1-1/4 RH	145489K	1.23	7	1000	150	1 1/4-11 1/2	7.44	5.63	0.50	2.499	3.75	3.125	0.406	1.25	0.125
1-1/2 RH	145461K	1.77	12	800	150	1 1/2-11 1/2	7.84	5.75	0.63	2.749	4.00	3.375	0.406	1.50	0.125
2 RH	146175	3.14	13	600	150	2-11 1/2	8.69	6.41	0.85	3.499	5.00	4.250	0.406	2.00	0.125
Size	Part Number	Passage Area	Weight Mass	Max. Speed ^①	Max. Pressure ^①	Inlet Thread ^②	D	D ₁	F	G ^③	H	K	L	N ^④	S
3/4 RH	145487K	3	1,6	1500	10,4	3/4-14	154	113	13	44,4	76	60,3	8,7	19	3,2
1 RH	145488K	5	2,0	1200	10,4	1-11 1/2	168	130	13	50,8	83	66,7	10,3	25	3,2
1-1/4 RH	145489K	8	3,2	1000	10,4	1 1/4-11 1/2	189	143	13	63,5	95	79,4	10,3	32	3,2
1-1/2 RH	145461K	11	5,4	800	10,4	1 1/2-11 1/2	199	146	16	69,8	102	85,7	10,3	38	3,2
2 RH	146175	20	5,9	600	10,4	2-11 1/2	221	163	22	88,9	127	108,0	10,3	51	3,2
SI		cm ²	kg	rpm	bar	Dimensions in millimeters									

Notes:

- ① Operation at maximum pressure and speed should be avoided. Refer to J-18 for operating parameters.
- ② American National Pipe Thread
- ③ Tolerance +0.000/-0.002 in (+0,00/-0,05 mm)
- ④ Tolerance +0.000/-0.005 in (+0,00/-0,13 mm)
- ⑤ Tolerance +0.002/-0.000 in (+0,05/-0,00 mm)
- ⑥ American National Standard for Unified Screw Threads.
- ⑦ Used to prevent the transmittal of stray electrical eddy currents.

Internal Rotorseals

Applications may arise where axial length is critical and space not available for an overhung rotorseal. If the shaft is of sufficient diameter, it may be possible to insert the rotorseal into the shaft end as shown in the figure at the right. The internal design and components are the same as those used in the single passage rotorseals.

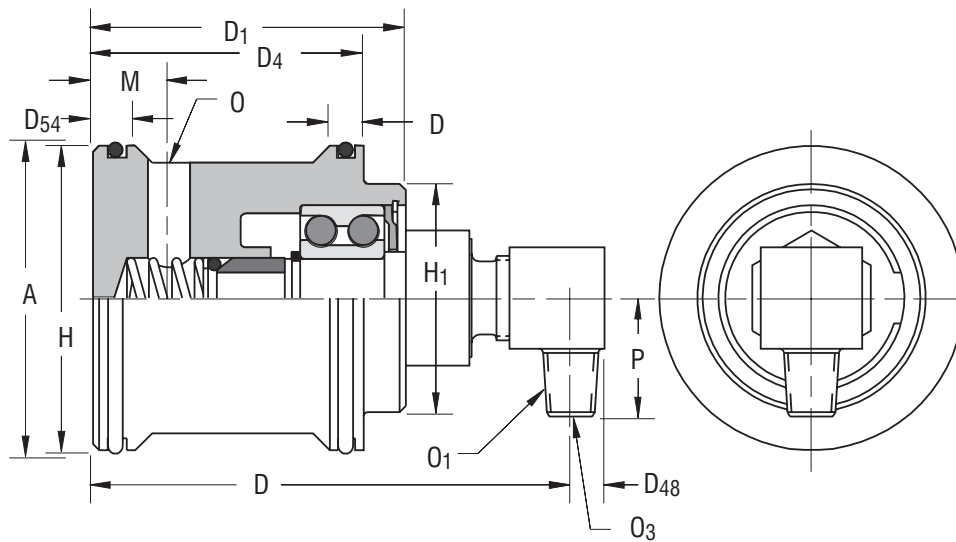
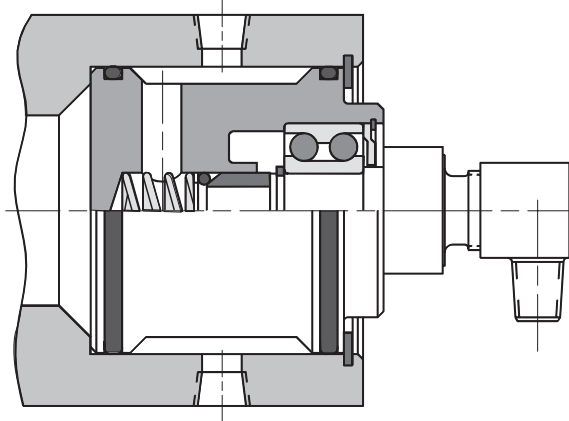

English		rpm	psi	in ²	lb	Dimensions in inches														
AA2	145631L	4000	150	0.019	0.4	0.63	1.596	3.19	2.00	2.000	0.22	0.41	0.25	1.498	1.50	0.41	0.19	1/8-27	0.16	0.63
B3	145106BM	4000	150	0.058	1	0.88	2.250	3.53	2.31	2.000	0.28	0.31	0.25	2.248	1.69	0.56	0.31	3/8-14	0.27	0.91
B3	145106BL	4000	150	0.058	1	0.88	2.625	3.53	2.31	2.000	0.28	0.31	0.25	2.623	1.88	0.56	0.31	3/8-14	0.27	0.91
C2	145107BA	3000	150	0.307	3	1.38	3.063	4.84	3.00	2.312	0.50	0.31	0.25	3.061	2.44	0.56	0.38		⑥	1.31
Type	Part Number	Max. ① Speed	Max. ① Pres.	Pass. Area	Weight Mass	Hex Size	A ^②	D	D ₁	D ₄ ③	D ₄₈	D ₅₄	D ₅₅	H ^④	H1	M	O	O ₁ ⑤	O ₃	P
AA2	145631L	4000	10,4	0,12	0,2	16	40,5	81	51	50,8	6	10	6	38,0	38	10	5	1/8-27	4	16
B3	145106BM	4000	10,4	0,37	0,5	22	57,2	90	59	50,8	7	8	6	57,1	43	14	8	3/8-14	7	23
B3	145106BL	4000	10,4	0,37	0,5	22	66,7	90	59	50,8	7	8	6	66,6	48	14	8	3/8-14	7	23
C2	145107BA	3000	10,4	1,98	1,4	35	77,8	123	76	58,7	13	8	6	77,7	62	14	10		⑥	33
SI		rpm	bar	cm ²	kg	Dimensions in millimeters														

Notes:

- ① Operation at maximum pressure and speed should be avoided. Refer to J-18 for operating parameters.
- ② Shaft counterbore diameter. Tolerance +0.002/-0.000 in (+0,05/-0,00 mm)
- ③ Tolerance +0.000/-0.005 in (+0,00/-0,13 mm)
- ④ Tolerance +0.000/-0.002 in (+0,00/-0,05 mm)
- ⑤ American National Pipe Thread
- ⑥ 1/2-14 American National Pipe Thread female port.

Component Part Descriptions

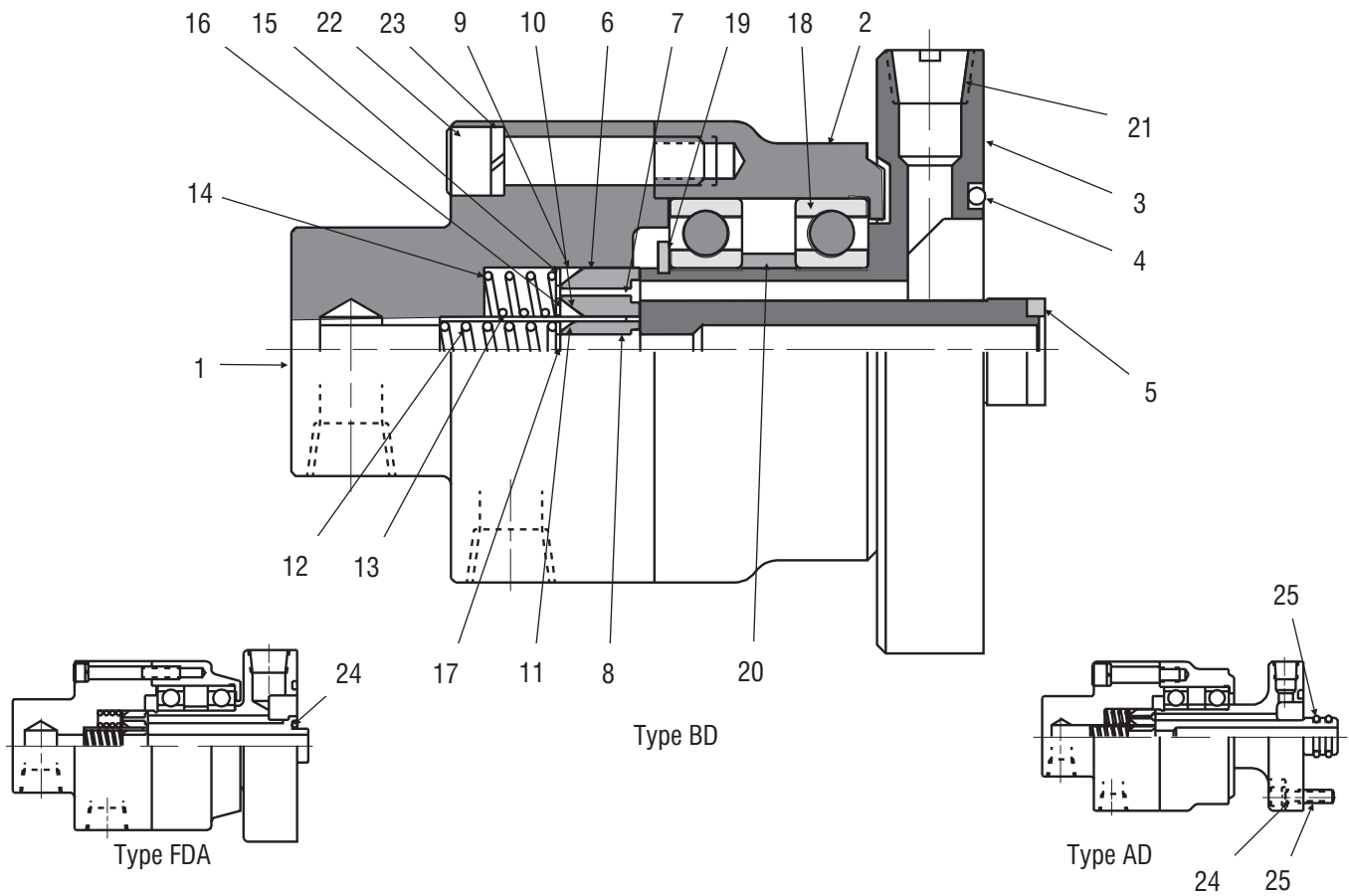

Item	Description
1	Rear Housing and Spring Retainer Assembly
2	Front Housing
3	Shaft
4*	Grommet
5*	Grommet
6*	Outer Carbon
7*	Intermediate Carbon
8*	Inner Carbon
9*	Outer "O" Ring
10*	Intermediate "O" Ring
11*	Inner "O" Ring
12*	Inner Seal Spring
13*	Intermediate Seal Spring
14*	Outer Seal Spring

Item	Description
15*	Outer Spring Retainer Ring
16*	Intermediate Spring Retainer Ring
17*	Inner Spring Retainer Ring
18	Bearing
19	Snap Ring
20	Bearing Spacer
21	Pipe Plug
22	Socket Head Cap Screw
23	Lockwasher
24*	Grommet
25*	Grommet
26	Hex or Socket Head Cap Screw
27	Lockwasher
*	Seal Kit (includes items marked *)

Dual Passage Rotorseals

Dual passage rotorseals allow the transfer of media through two separate shaft passages located on the same shaft end. Each passage can be used for a different medium; for instance, air for clutch actuation and oil for bearing lubrication. Inlet and outlet ports have American National Pipe Threads.

Type AD

The AD rotorseal has 1/4-18 inlet ports for each of the passages. Both passage outlets can discharge directly into the shaft end. An optional 1/4-18 outlet port in the mounting flange could be used for the outer passage. The inner passage nose is sealed on its outside diameter by a pair of "O" rings. The outer passage is sealed to the shaft end with a compression grommet.

Type ADP

The type ADP rotorseal attaches to the shaft end with a 1-11 1/2 thread outlet instead of a mounting flange. The outer passage outlet feeds into the

end of the machine shaft. The inner passage is a 1/4-18 port located on a flat of the hex mounting nut.

Type BD

The type BD is similar to the AD, except for a larger diameter mounting flange. The inner passage is sealed with a flat rubber washer which compresses on the bottom of a counterbore in the shaft end. A compression grommet is used between the shaft end and mounting flange to seal the outer passage.

Type FDA

The FDA type rotorseal has larger passages than the BD rotorseal. The two inlet ports and the two flange outlet ports for the outer passage are 1/2-14. Compression grommets are used between the shaft end and mounting flange to seal the inner and outer passages.

English		in ²	in ²	rpm	psi	lb
AD	145785C	0.049	0.155 ②	1200	150	4.3
ADP	145785B	0.049	0.124 ③	1200	150	4.0
BD	145405T	0.049	0.171 ④	1200	150	5.8
FDA	145583AJ	0.196	0.221 ⑤	1000	150	9.4

Size	Part Number	Passage Area		① Maximum Speed	① Maximum Pressure	Weight
		Inner	Outer			Mass
AD	145785C	0,32	1,00 ②	1200	10,4	1,9
ADP	145785B	0,32	0,80 ③	1200	10,4	1,8
BD	145405T	0,32	1,10 ④	1200	10,4	2,6
FDA	145583AJ	1,26	1,43 ⑤	1000	10,4	4,3

SI		cm ²	cm ²	rpm	bar	kg
AD	145785C	0,049	0,155 ②	1200	10,4	1,9
ADP	145785B	0,049	0,124 ③	1200	10,4	1,8
BD	145405T	0,049	0,171 ④	1200	10,4	2,6
FDA	145583AJ	0,196	0,221 ⑤	1000	10,4	4,3

English	Dimensions in inches																
AD	5.69	4.56	0.75	0.75	4.14	1.13	3.25	1.75	2.562	3.250	2.17	1.50	0.34	0.38	1/4-18	0.38	0.798
ADP	5.28	4.16	1.00	1.00	3.73	1.13	3.25	1.75	N/A	N/A	N/A	N/A	N/A	0.50	1/4-18	③	N/A
BD	4.88	3.75	0.393 ⑥	0.75	3.34	1.13	3.25	1.75	3.562	4.250	2.78	1.88	0.40	0.38	1/4-18	0.38	0.750
FDA	6.31	4.94	0.25	1.19	4.22	1.47	3.75	2.06	3.562	4.250	3.22	2.25	0.40	0.63	1/2-14	0.50	0.750
Size	D	D ₁	D ₃₀	D ₃₁	D ₄₈	D ₄₉	H	H ₁	H ₂	H ₁₁ ⑥	H ₁₃	H ₁₆	L	M	O ₁ ⑦	O ₂	S ⑧
AD	145	116	19	19	105	29	83	44	65,1	82,6	55	38	9	10	1/4-18	10	20,3
ADP	134	106	25 ⑥	25	95	29	83	44	N/A	N/A	N/A	N/A	N/A	13	1/4-18	③	N/A
BD	124	95	10,0	19	85	29	83	44	90,5	108,0	71	48	10	10	1/4-18	10	19,1
FDA	160	125	6	30	107	37	95	52	90,5	108,0	82	57	10	16	1/2-14	13	19,1
SI	Dimensions in millimeters																

Notes:

- ① Operation at maximum pressure and speed should be avoided. Refer to J-18 for operating parameters.
- ② Passage consists of ten 0.14 in (3,6 mm) diameter holes.
- ③ Passage consists of eight 0.14 in (3,6 mm) diameter holes.
- ④ Passage consists of eleven 0.14 in (3,6 mm) diameter holes.
- ⑤ Passage consists of eight 0.18 in (4,8 mm) diameter holes.
- ⑥ Tolerance +0.000/-0.001 in (+0,00/-0,03 mm)
- ⑦ American National Pipe Thread
- ⑧ Tolerance +0.000/-0.002 in (+0,00/-0,05 mm)
- ⑨ Tolerance +0.000/-0.003 in (+0,00/-0,08 mm)

Airflex® Dual Passage Rotorseals



Forms RS905 & RS906 Dimensional Data Types AD, ADP, BD & FDA

Type AD

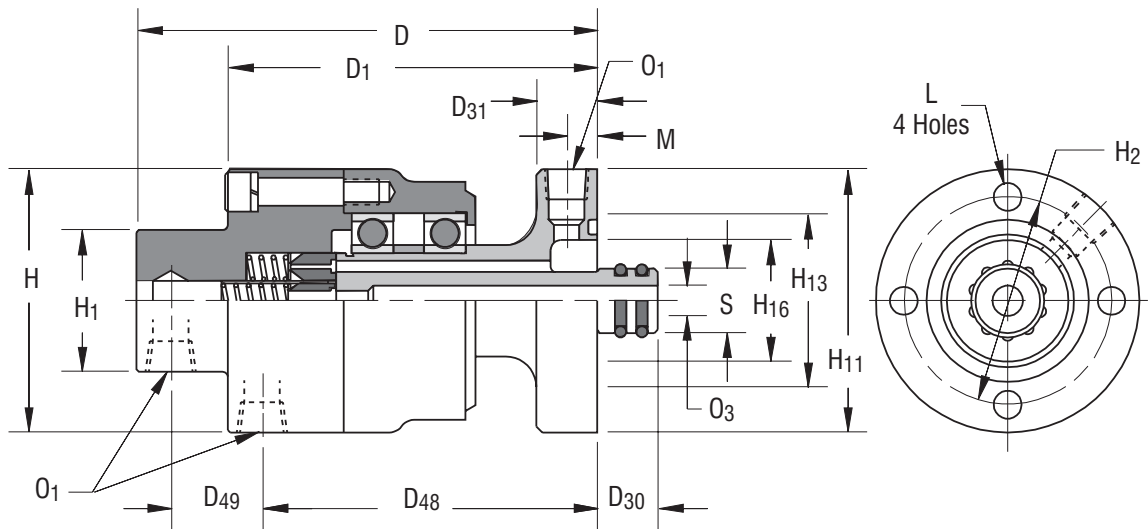

Type ADP

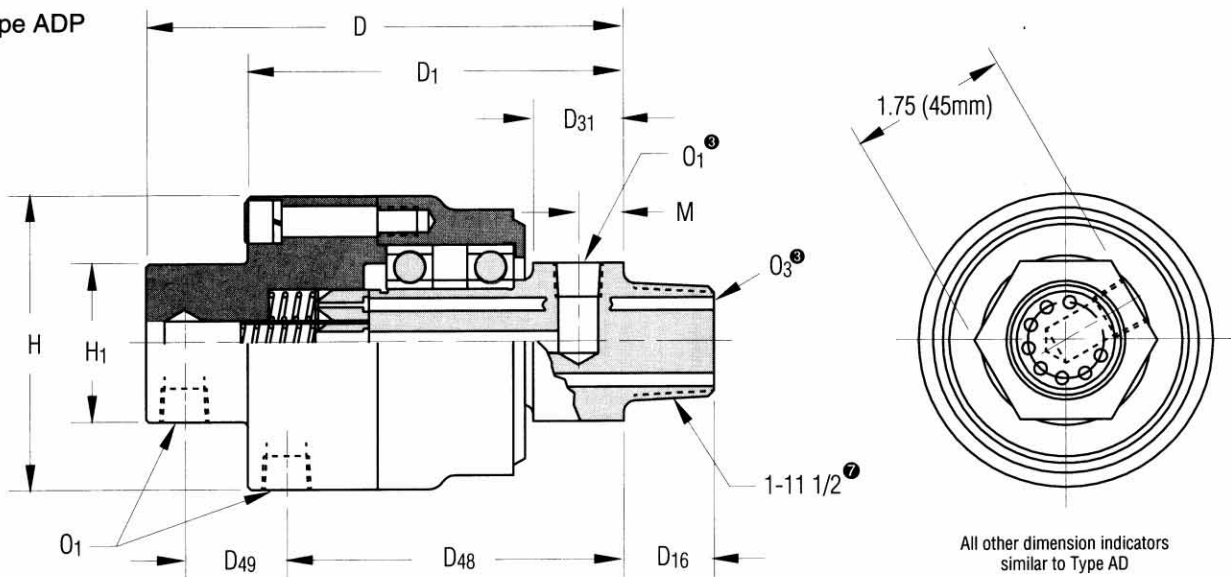

Type BD & FDA

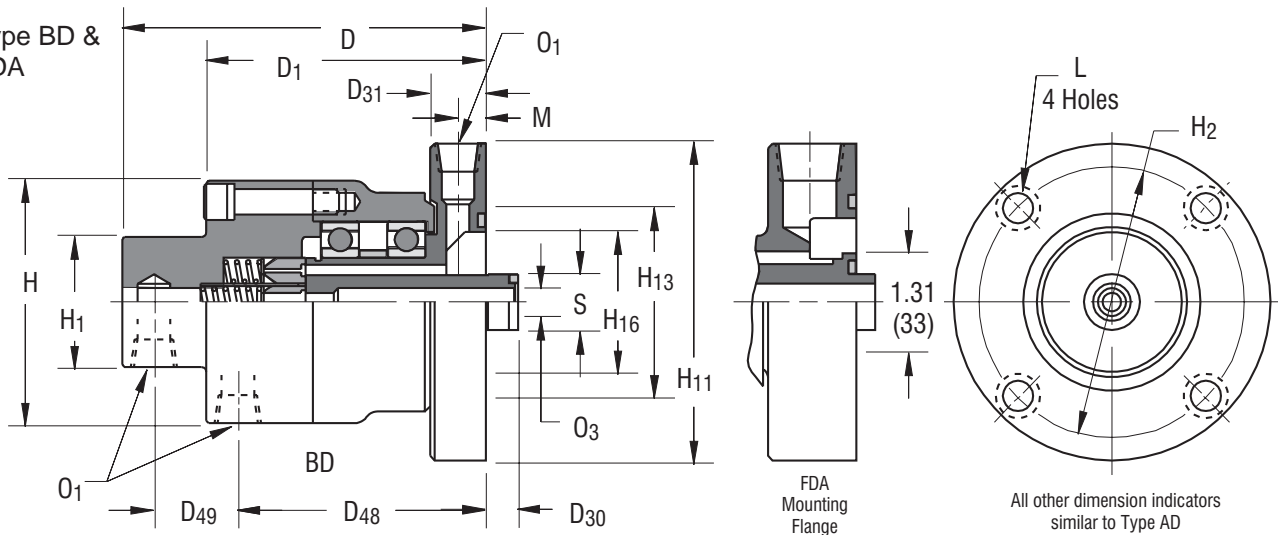

Dimensional Data

Airflex RD Dual Passage Rotorseals are designed to simultaneously transmit two different fluids (or gasses) into or out of machinery through a rotating shaft.

These heavy-duty units were designed to transmit actuating fluid and cooling oil into hydraulic clutches. They can be used with mineral oil, water, and air. The rotating seal is provided by a non-metallic sealing ring, held

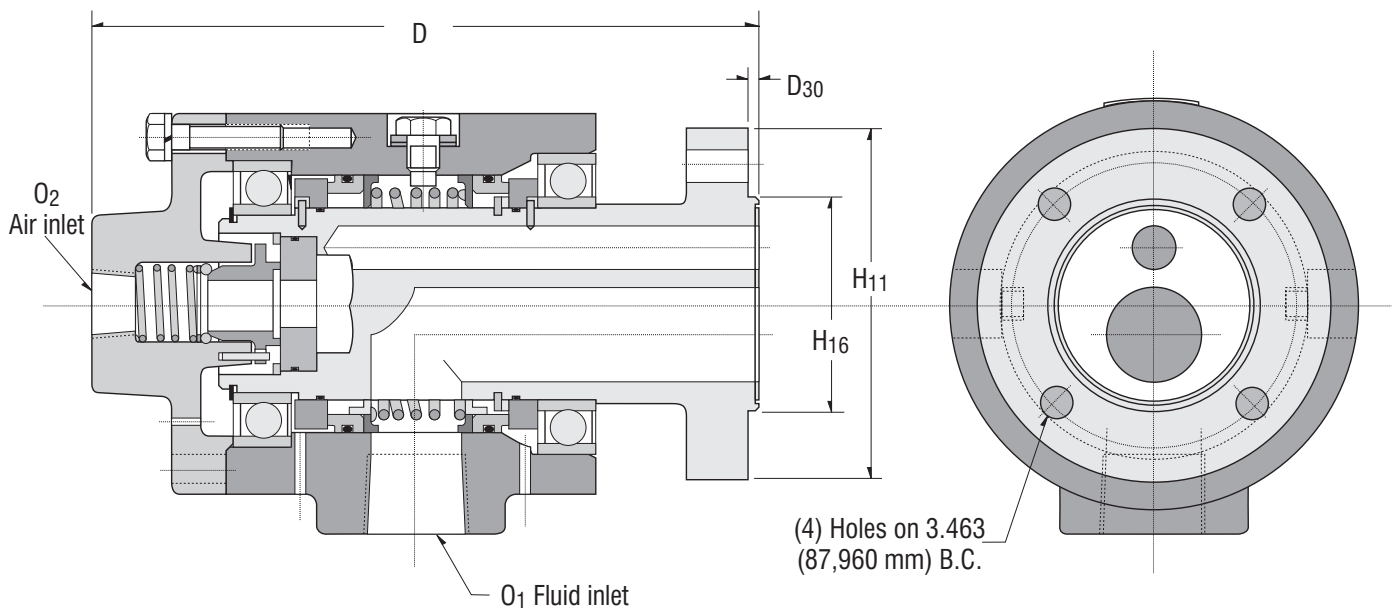

Technical Data	English Units	SI Units
Maximum Speed	1200 rpm	
Maximum Pressure through 1" passage*	75 psi	5,15 bar
Maximum Pressure through 0.5" passage*	150 psi	10,3 bar
Weight	25 lbs	11,34 kg

*Operation at both maximum speed and pressure should be avoided

Dimension	inches	millimeters
D	8.318	211,277
D₃₀	0.125 - 0.130	3,175 - 3,302
H₁₁	4.38	111,252
H₁₆	2.622 - 2.625	66,599 - 66,675
O₁	1-11 1/2 NPT	
O₂	1/2-14 NPT	

Component Parts

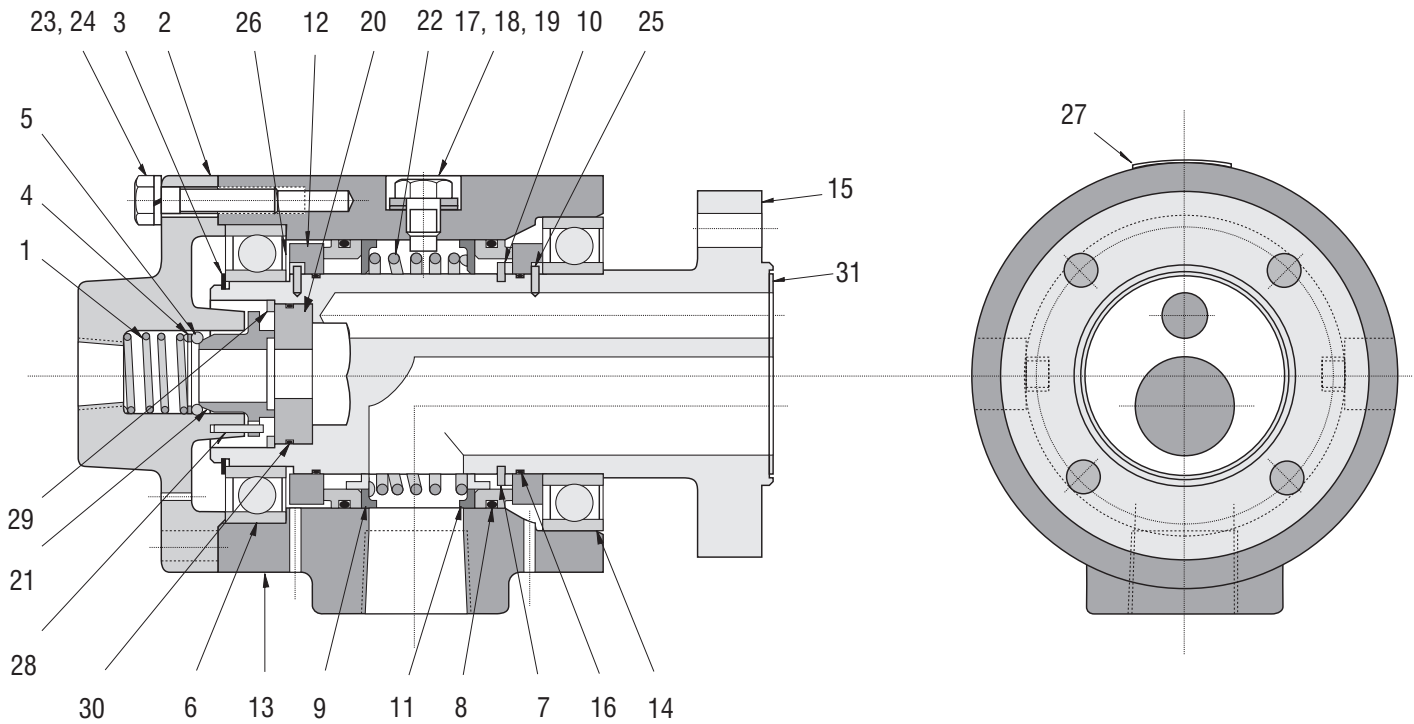

Item	Quantity	Description	Part. No.
1	1	Spring	009479
2	1	End Cap	415421
3	1	Snap Ring	000118x0022
4	1	Spring Retainer	009480
5	1	"O" Ring	000073x0384
6	1	Bearing	000159x0188
7	1	Snap Ring	307839
8	2	"O" Ring	000073x0382
9	2	Anti-Rotation Washer	307779
10	1	Spacer	307730
11	2	Face Seal	307726
12	2	Wear Ring	307725
13	1	Housing	513002
14	1	Bearing	000159x0085
15	1	Flanged Shaft	513016
16	2	"O" Ring	000073x0383

Item	Quantity	Description	Part. No.
17	2	Washer	000067x0038
18	2	Hex. Head Screw	307789
19	2	Thread seal	000341x0002
20	1	Shaft End Insert	307857
21	1	Carbon Seal	307858
22	1	Spring	307883
23	4	Hex Head Screw	000383x0109
24	4	Lock washer	000153x0809
25	5	Dowel Pin	000153x1085
26	1	Washer	307788
27	1	Rotorseal Handling Label	307942
28	2	Roll Pin	000382x0039
29	1	Snap Ring	000138x0067
30	1	"O" Ring	000073x0364
31	1	Gasket	307884

Type BTA

The BTA rotorseal was designed for simultaneous transfer of as many as three different fluids. A mounting flange simplifies installation to the shaft end. Three 1/2-14 American National Pipe Thread inlet ports on the side of the stationary rotorseal body provide access to the concentric fluid passages. All three passages can discharge directly into the rotating shaft. However, a 1/2-14 port in the mounting flange can be used as an optional outlet for the outermost passage.

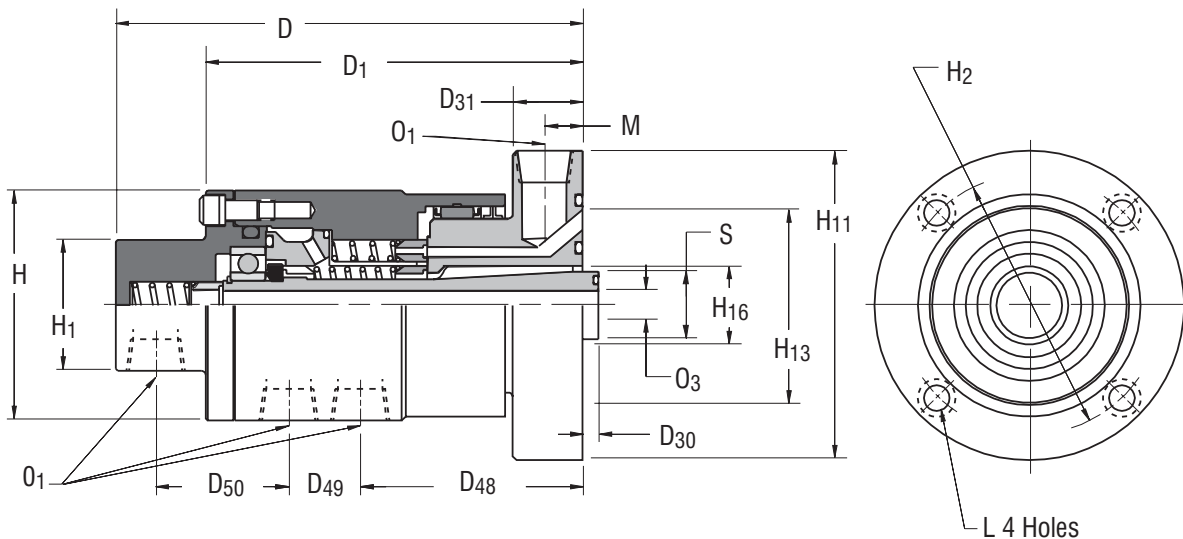

Technical Data	English Units	SI Units
Inner Passage Area	0.196 in ²	1,26 cm ²
Intermediate Passage Area	0.260 in ²	1,68 cm ²
Outer Passage Area ❶	0.307 in ²	1,98 cm ²
Maximum Speed ❷	1000 rpm	1000 rpm
Maximum Pressure ❷	150 psi	10,3 bar
Weight/Mass	11 lb	5 kg

Dimension	inches	millimeters
D	7.34	186
D₁	5.94	151
D₃₀	0.250	6,4
D₃₁ ❸	1.09	28
D₄₈	3.50	89
D₄₉	1.13	29
D₅₀	2.09	53
H	3.63	92
H₁	2.06	52

Dimension	inches	millimeters
H₂	4.125	104,8
H₁₁	4.88	124
H₁₃	3.14	80
H₁₆	1.25	32
L	0.40	10
M	0.59	15
O₁ ❹	1/2-14	1/2-14
O₃	0.47	12
S ❺	1.063	27,0

Notes:

- ❶ Passage consists of sixteen 0.15 in (3,8 mm) diameter holes.
- ❷ Operation at maximum pressure and speed should be avoided. Refer to J-18 for operating parameters.
- ❸ Tolerance +0.005/-0.000 in (+0,08/-0,00 mm)
- ❹ American National Pipe Thread
- ❺ American National Standard for Unified Screw Threads.
- ❻ Tolerance +0.000/-0.001 in (+0,00/-0,03 mm)
- ❼ Tolerance +0.010/-0.000 in (+0,25/-0,00 mm)
- ❽ Tolerance +0.001/-0.000 in (+0,03/-0,00 mm)

Component Part Descriptions

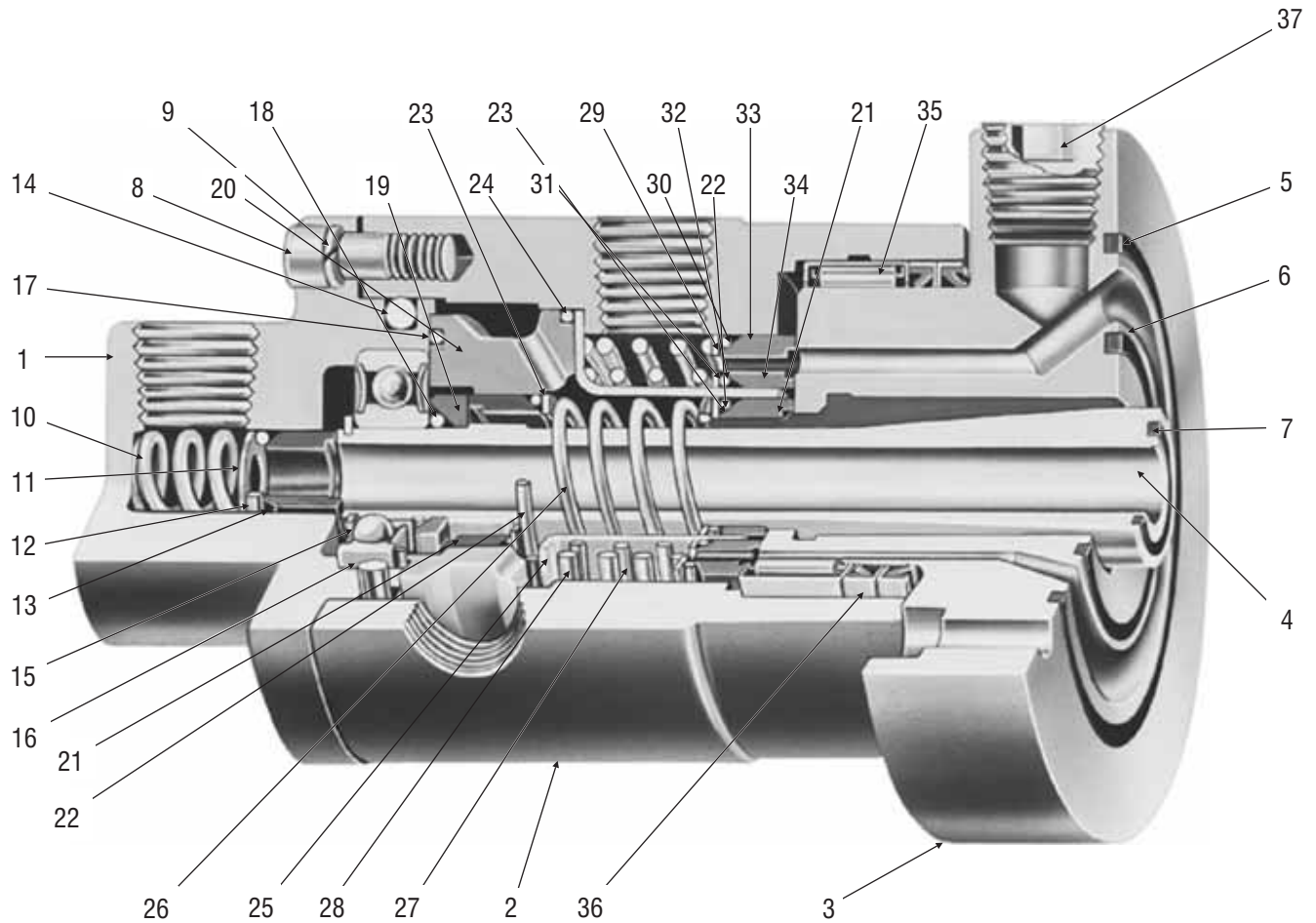

Item	Description
1	Rear Housing
2	Front Housing
3&4	Shaft Assembly
5*	Outer Grommet
6*	Intermediate Grommet
7*	Inner Grommet
8	Socket Head Cap Screw
9	Lockwasher
10	Rear Seal Spring
11*	Rear Seal Washer
12*	Rear Seal "O" Ring
13*	Rear Carbon Seal
14	Housing "O" Ring
15	Snap Ring
16	Ball Bearing
17*	Seal Support Rear "O" Ring
18*	Seal Ring "O" Ring
19	Seal Ring
20	Seal Support

Item	Description
21*	Inner Carbon Seal
22*	Inner Carbon Seal "O" Ring
23*	Inner Seal Washer
24*	Seal Support Front "O" Ring
25	Sleeve
26*	Inner Spring
27*	Intermediate Spring
28*	Outer Spring
29*	Outer Seal Washer
30*	Outer Carbon Seal "O" Ring
31*	Intermediate Seal Washer
32*	Intermediate Carbon Seal "O" Ring
33*	Outer Carbon Seal
34*	Intermediate Carbon Seal
35	Needle Bearing
36	Shaft Seal
37	Pipe Plug
*	Seal Replacement Kit (includes parts marked *)

Airflex[®] RT Triple Passage Rotorseal



Dimensional Data

Airflex RT Triple Passage Rotorseals™ are designed to simultaneously transfer three different fluids (or combination of fluid and gases) into or out of machinery through a rotating shaft or body. The RT Rotorseal has two 1" and one 0.5" diameter passageways and is available in a standard cast iron shaft design or a corrosion-resistant model with a brass shaft.

These heavy-duty units were designed primarily for the passage of fluids to water-cooled clutches. Other applications include the transmittal of cutting fluid to machine tools, lubrication of shaft-mounted components and circulation of water or oil for cooling systems.

The rotating seal is provided by a non-metallic sealing ring, held against the rotorseal shaft by a light spring force. The design promotes positive protection against leakage and minimal seal wear. Ball bearings are used between the stationary and rotating ports to provide rigidity to the rotorseal assembly and to minimize the running torque.

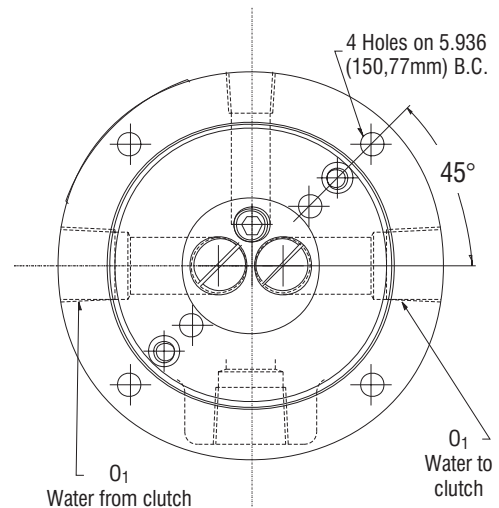
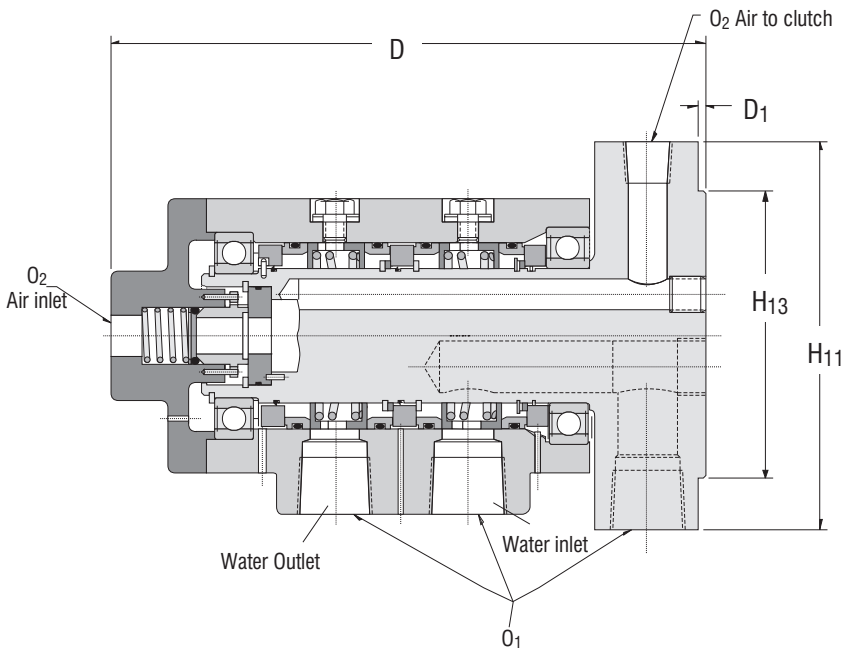

Technical Data	English Units	SI Units
Maximum Speed	1200 RPM	
Maximum Pressure through 1" passages	75 psi*	5,15 bar
Maximum Pressure through 0.5" passages	150 psi*	10,3 bar
Weight	34 lbs	15,4 kg

* Operation at both maximum speed and pressure should be avoided.

Dimension	inches	millimeters
D	10.35	262,89
D₁	0.125	3,175
H₁₁	6.75	171,45
H₁₃	4.997	126,924
O₁	1-11 1/2 NPT	
O₂	1/2-14 NPT	

Component Part Descriptions

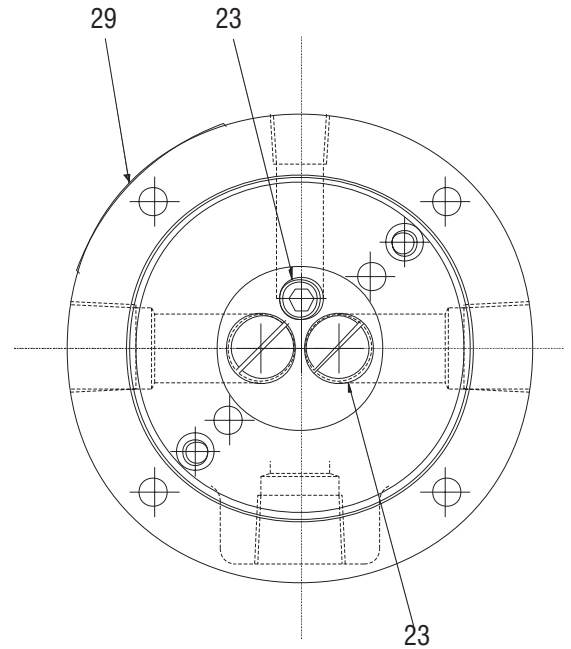
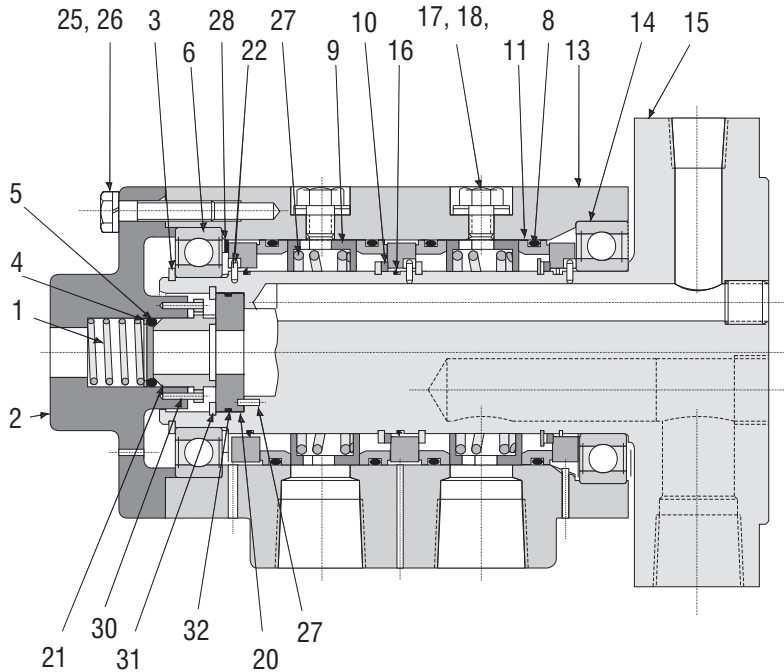

Part Number Reference

Cast iron model: 146256A

Corrosion resistant model: 146256B

Item	Description	Part Number		Quantity
		146256A	146256B	
1	Spring	009479	009479	1
2	End Cap	415421	415421	1
3	Snap Ring	000118x0022	000118x0022	1
4	Spring Retainer	009480	009480	1
5	"O" Ring	000073x0010	000073x0010	1
6	Bearing	000159x0188	000159x0188	1
7	Snap Ring	307839	307839	3
8	"O" Ring	000073x0331	000073x0331	4
9	Anti-Rotation Washer	307779	307779	4
10	Spacer	307730	308145	2
11	Face Seal	307726	307726	4
12	Wear Ring	307725	307725	3
13	Housing	512672	512672	1
14	Bearing	000159x0085	000159x0085	1
15	Flanged Shaft	513306	513761	1
16	"O" Ring	000073x0332	000073x0332	3

Item	Description	Part Number		Quantity
		146256A	146256B	
17	Washer	000067x0038	000067x0038	2
18	Hex Head Screw	307789	307789	2
19	Threadseal	000341x0002	000341x0002	2
20	Shaft End Insert	307857	307857	1
21	Carbon Seal	307858	307858	1
22	Spring	307719	307719	2
23	Socket Head Plug	000037x0604	000037x0604	1
24	Slotted Head Plug	000153x0796	000153x0796	2
25	Hex Head Screw	000383x0109	000383x0109	4
26	Lockwasher	000153x0796	000153x0796	4
27	Dowel Pin	000153x1085	000153x1085	7
28	Washer	307788	307788	1
29	Rotorseal Handling Label	307942	307942	1
30	Roll Pin	000382x0039	000382x0039	2
31	Snap Ring	000138x0067	000138x0067	1
32	"O" Ring	000073x0364	000073x0364	1

Types AD, BD, FDA, & BTA

Dual Passage Rotorseal

The diagrams on the right illustrate typical shaft drilling for fluid passages.

In the top diagram, one outlet is required out-board of the shaft support bearing. This outlet can be the one provided in the mounting flange of the rotorseal. The second outlet, between the shaft bearings, requires an axial hole and cross drilling.

In the bottom diagram, both outlets are between the shaft bearings. A bayonet assembly, consisting of a length of steel tubing properly supported at both ends, is inserted into the axial hole. One passage is formed by the outside diameter of the tube and the wall of the axial hole. The inner passage is the inside diameter of the tube. Rubber grommets are used at the inner bayonet support to seal the passages from each other.

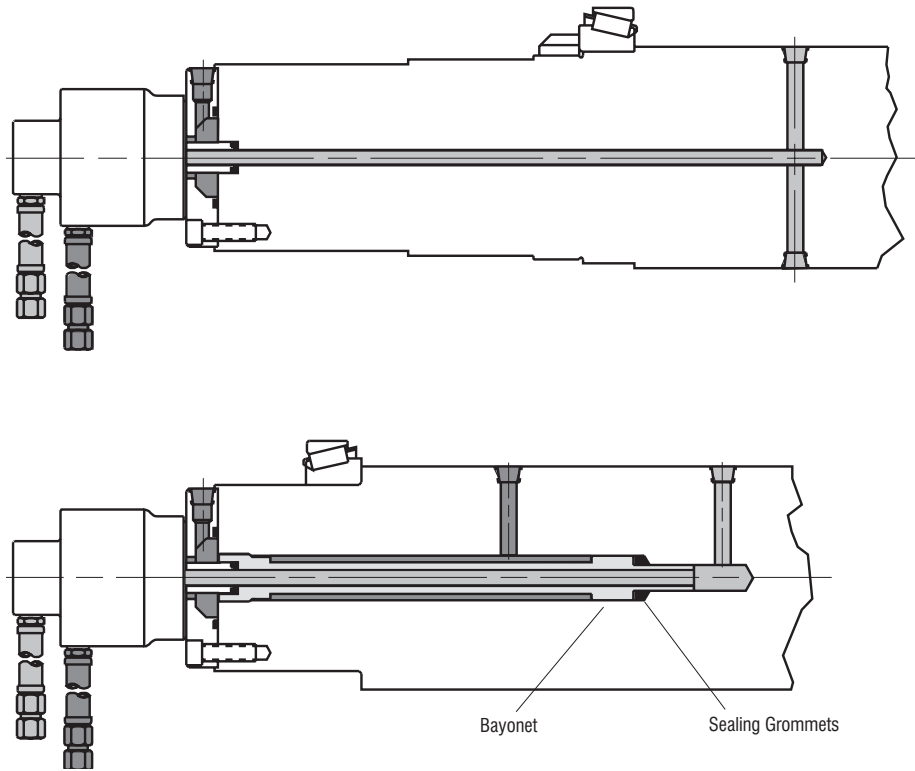

Triple Passage Rotorseal

The diagram on the right illustrates a BTA rotorseal mounting to shaft diameters smaller than the rotorseal mounting flange. The manifold and adapter plate are not required for larger diameter shafts.

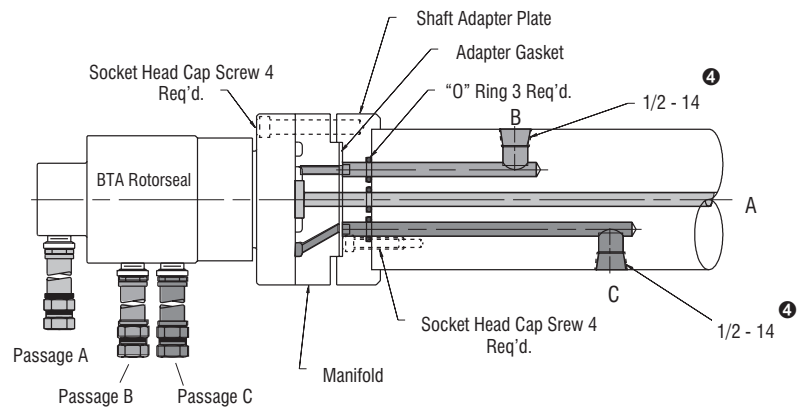

Shaft End Machining

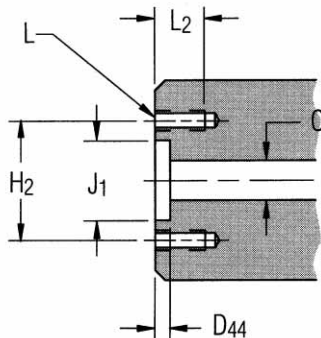

English	Dimensions in inches					
AD	0.81	2.562	0.800	5/16-18	0.56	0.38
BD	0.395 ⑧	3.562	0.751	3/8-16	0.50	0.38
BTA	0.255 ⑨	4.125	1.064	3/8-16	0.75	0.47
FDA	0.31	3.562	0.751	3/8-16	0.75	0.50
Type	D ₄₄	H ₂	J ₁ ⑥	L ⑦	L ₂	O
AD	21	65,1	20,3	5/16-18	14	10
BD	10,0 ⑧	90,5	19,1	3/8-16	13	10
BTA	6,5 ⑨	104,8	27,0	3/8-16	19	12
FDA	8	90,5	19,1	3/8-16	19	13
SI	Dimensions in millimeters					

Temperature

Rotorseal maximum operating temperature is dependent upon the sealing “O” ring and grommet rubber compounds and/or the type of ball bearings used in their design. The following temperatures should not be exceeded.

Rotorseal Type	Operating Temperature
AA2, B3 & C2	200°F (93°C)
All other types	130°F (54°C)

Pressure and Speed

The allowable pressure shown for each rotorseal is determined by the bursting strengths of the carbon sealing ring. Maximum rpm is determined by the bearings used. Operation at maximum pressure and speed should be avoided. Rather for good carbon seal life, operating pressure and speed should satisfy the following:

$$K \geq C_1 \cdot n + C_2 \cdot n \cdot p_o$$

where

$$K = 45000 \text{ for air}$$

$$K = 50000 \text{ for fluids}$$

$$n = \text{Operating rpm}$$

$$p_o = \text{Operating pressure psi (bar)}$$

C_1 & C_2 = Constants from following table

Rotorseal Type	C_1	C_2	
		English	SI
AA2	3.41	0.098	1,421
B3	4.80	0.070	1,015
C2	9.04	0.113	1,639
3/4 RH	10.25	0.143	2,074
1 RH	11.68	0.165	2,393
1 1/4 RH	34.61	0.205	2,973
1 1/2 RH	52.04	0.237	3,437
2 RH	7.53	0.034	0,493
AD, ADP & BD	1.14	0.162	2,349
FDA	9.25	0.235	3,408
BTA	2.25	0.052	0,754

Compatibility

The media which flows through the rotorseal must be compatible with the rotorseal materials it contacts. In general, the housings are an aluminum alloy, the shafts and springs are steel and the seals are carbon. The components most susceptible to attack, both chemically and thermally, are the “O” rings and grommets. As an example, shop air may contain synthetic lubricant from the compressor or, in the case of an outdoor installation, a deicer may be added to the compressor air. Composition of the “O” rings and grommets are given in the table.

Internal “O” Rings	Flange and Nose Grommets	Material
AA2, B3, C2 1, 1 1/4, 1 1/2 RH	3/4, 1, 1 1/4, 1 1/2 & 2 RH AD, FDA & BTA BD (Flange only) RD (Flange Gasket)	Buna N
3/4 & 2 RH FDA, BTA, RD		Viton
AD, ADP, BD	BD (Nose only)	Neoprene
RT		Buna N, Viton, Ethylon Propylene

Example

A B3 rotorseal will be used to transmit air to a 2000 rpm shaft. For good seal life, what is the maximum allowable air pressure?

$$K = 45000$$

$$C_1 = 4.80$$

$$C_2 = 0.70 (1,015)$$

$$n = 2000$$

$$C_1 \cdot n + C_2 \cdot n \cdot p = K$$

$$4.800 \cdot 2000 + 0.070 \cdot 2000 \cdot p = 45000$$

$$140 p = 45000 - 9600$$

$$p = 253 \text{ psi (18 bar)}$$