

STAINLESS STEEL MACHINE SCREW JACKS

ActionJac™ Stainless Steel Machine Screw Jacks are ideal for use in demanding environments where corrosion resistance is required. All external components are manufactured from 300 series Stainless Steel materials. These jacks use a stainless steel worm with a high strength bronze drive sleeve. The worm and drive sleeve are supported by tapered roller bearings and sealed to prevent loss of lubrication and to resist contamination. The stainless steel lifting screw threads are precision formed to Class 2-C (centralizing) thread profiles.

Load capacities for Stainless Steel Machine Screw Jacks range from 1,300 to 23,000 pounds. A 17-4PH hardened worm is available for a 300% increase in capacity.

See the technical introduction at the beginning of this section for a description of Stainless Steel Machine Screw Jack features.

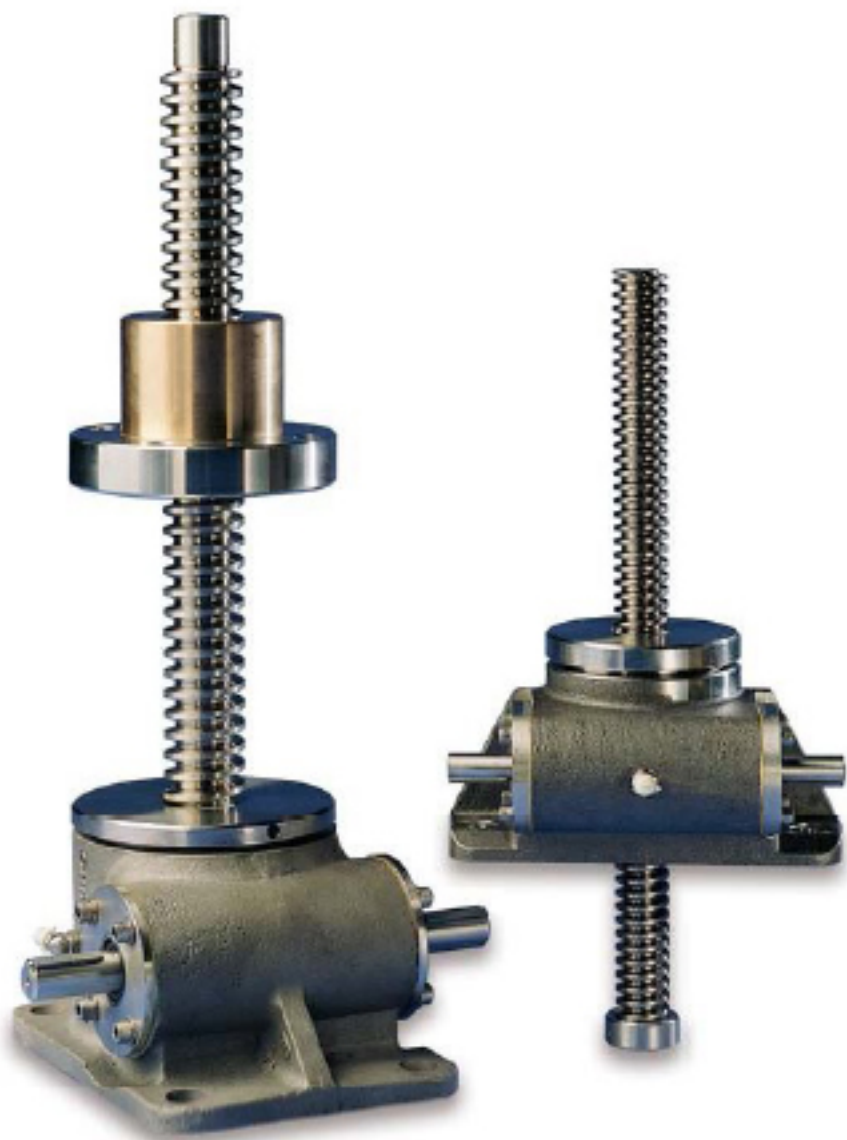

Download Accurate Moveable Assembly 3D Models and 2D Drawings

For ActionJac™ Worm Gear Screw Jacks:

- **Configure** specific requirements for your Worm Gear Screw Jack application in a simple interface, including motor adapter, right angle reducer, bellows boots and limit switch accessories.
- **View** complete assemblies on-line with zoom, pan and rotate capabilities.
- **Download** true assembly models with full range of motion in native AutoCAD®, SolidWorks®, Pro/E®, CATIA®, ParaSolids®, SAT® and many other formats.
- **Order** complete jack assemblies with generated part number.



FU IBERICA, S.L.U.
TRANSMISION DE POTENCIA

Tel. (+34)+34 932 681 833

Fax (+34)+34 932 683 292

<http://www.fuiberica.com>
fuiberica@fuiberica.com

JACK SIZES					JACK SELECTION								Page Ref
MODEL	Capacity (tons)	Lifting Screw Dia. (in)	Screw Lead (in)	Root Dia. (in)	Gear Ratio	Turns of Worm for 1" Travel	Maximum Input Torque (in.-lb.)	Maximum Allowable Input (hp)	Maximum Worm Speed at Rated Load	Maximum Load at 1750 RPM	Torque to Raise 1 lb. (in.-lb.)	Tare Drag Torque (in.-lb.)	
2SS-MSJ	0.66	1	.250	.698	6:1	24	33	2	1800	1330	.0250	4	337
					24:1	96	14	1/2	1800	1320	.0150	4	337
5SS-MSJ	1.67	1 1/2	.375	1.066	6:1	16	125	3	1510	2873	.0376	10	338
					24:1	64	48	3/4	985	1875	.0144	10	338
10SS-MSJ	3.33	2	.500	1.410	8:1	16	251	5	1255	4775	.0377	20	339
					24:1	48	128	1 1/2	739	2813	.0192	20	339
15SS-MSJ	5.00	2 1/4	.500	1.684	8:1	16	407	5	774	4424	.0407	20	340
					24:1	48	218	1 1/2	434	2478	.0218	20	340
20SS-MSJ	6.66	2 1/2	.500	1.908	8:1	16	580	5	540	4140	.0435	40	341
					24:1	48	291	1 1/2	325	2478	.0218	40	341
25SS-MSJ	8.30	3	.667	2.287	10 ^{2/3} :1	16	903	11	768	8764	.0452	50	342
					32:1	48	471	3 1/2	468	5364	.0235	50	342
35SS-MSJ	11.66	3 3/4	.667	3.083	10 ^{2/3} :1	16	1150	11	603	8035	.0493	50	343
					32:1	48	600	3 1/2	368	5022	.0251	50	343

* Measurements listed are for non-keyed units. See individual jack pages for keyed jack info.

NOTES:

1) The recommended maximum speed is 1800 rpm provided that the recommended horsepower and temperature are not exceeded.

2) Input torque is shown as torque to lift one pound of load. Starting Torque is 100% greater than torque shown. Tare drag torque should be added for all loads.

3) Maximum allowable horsepower ratings are based on a 25% duty cycle. For operation at higher duty cycles or repeated use over any segment of the total travel, temperature must be monitored and remain less than 200°F.

4) Overload capacity of the Stainless Steel Machine Screw Jack is as follows: 10% for dynamic loads, 30% for static loads.

5) Stainless Steel Machine Screw Jacks having gear ratios between 20:1 and 32:1, are self-locking and will hold loads without backdriving in the absence of vibration. All other ratios may require a brake to prevent backdriving.

6) All units are suitable for intermittent operation providing that the housing temperature including ambient is not lower than -20°F. or higher than +200°F. Factory supplied grease in standard units will operate in this range. For higher or lower operating temperature ranges consult Nook Industries.

7) Accessories such as boots, top plates and clevises are available.

8) Catalog dimensions are representative only and are subject to change without notice. For construction, use only certified prints.

9) Units are not to be used as personnel support or movement.

10) End-of-travel stops are not provided.

‡ For greater capacity, specify a 17-4PH hardened worm.

* Tare drag torque need only be added if operating under 25% rated load.

$$\text{Horsepower per jack} = \frac{\text{Torque to raise one pound} \times \text{Number of pounds to be raised} \times \text{rpm}}{63,025}$$

Starting Torque is 100% greater than torque shown.

Column strength is the ability of the lift shaft to hold compressive loads without buckling. With longer screw lengths, column strength may be substantially lower than nominal jack capacity.

If the lift shaft is in tension only, the screw jack travel is limited by the available screw material or by the critical speed of the screw. Refer to the acme screw technical section for critical speed limitations. If there is any possibility for the lift shaft to go into compression, the application should be sized for sufficient column strength.

The chart below is used to determine the required jack size in applications where the lift shaft is loaded in compression.

To use this chart:

Find a point at which the maximum length “L” intersects the maximum load. Be sure the jack selected is above and to the right of that point.

CAUTION: chart does not include a design factor.

The chart assumes proper jack alignment with no bending loads on the screw. Effects from side loading are not included in this chart. Jacks operating horizontally with long lift shafts can experience bending from the weight of the screw. Consult Nook Industries, Inc. if side thrust is anticipated, operating horizontally, or maximum raise is greater than 30 times the screw diameter.

IF 17-4PH WORM IS ORDERED, REFER TO PAGE 316 FOR COLUMN STRENGTH

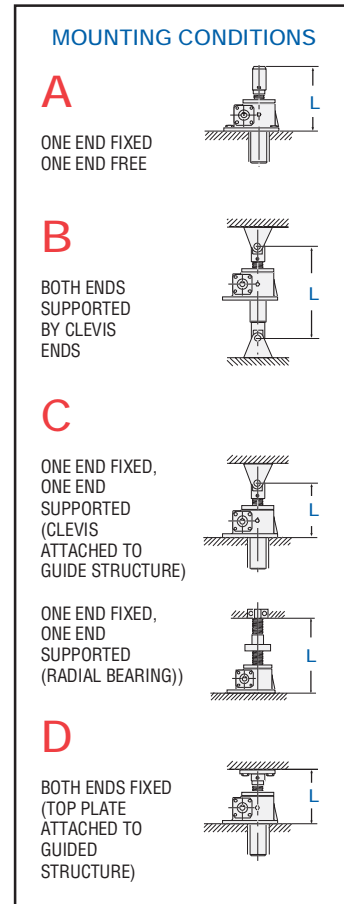
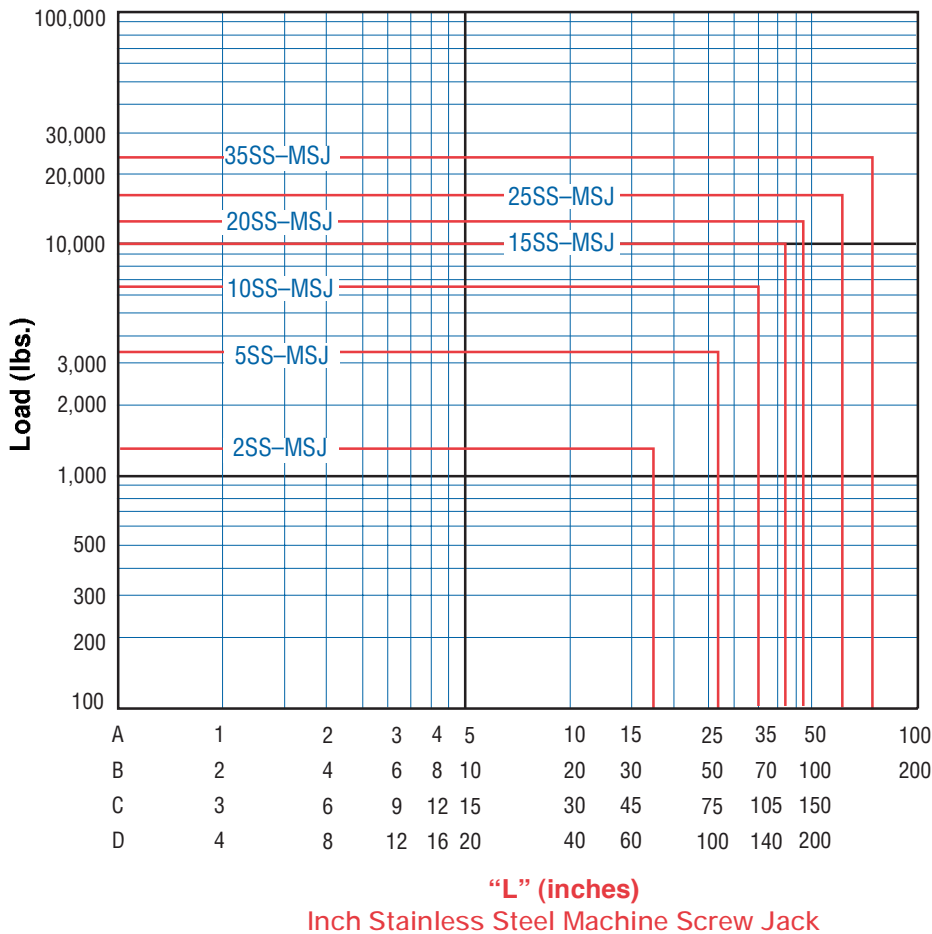

AVAILABLE LIFT SCREW LENGTHS

As a major manufacturer of industrial lead screws, Nook Industries stocks a broad selection of stainless acme screws. Nook Industries has the capacity to make long acme screws for special applications. Rotating screw

jacks can be built with a larger diameter lift screw for greater column strength, or a different lead to change the jack operating speed.

2SS-MSJ- U 6:1 / SSE-1 / 000-2 / FT / 24.5 / SB

SS MACHINE SCREW MODEL

Ton Model #
 0.66 = 2SS-MSJ
 1.67 = 5SS-MSJ
 3.33 = 10SS-MSJ
 5.00 = 15SS-MSJ
 6.66 = 20SS-MSJ
 8.30 = 25SS-MSJ
 11.66 = 35SS-MSJ

CONFIGURATION

U = Upright
 I = Inverted
 UR = Upright Rotating
 IR = Inverted Rotating

GEAR RATIO

Refer to product pages for available ratios.

SHAFT ORDER CODE

CCW Position 1
 CW Position 2

ORDER CODES (Must Include A Position)

NO ACCESSORY

SSE-__ = Standard Shaft Extension, Position 1 or 2
 000-__ = Delete Shaft Extension, Position 1 or 2
 SPC-__ = Special Modified Shaft Extension, Position 1 or 2

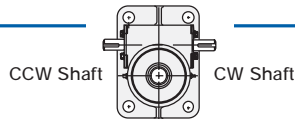

NOTE: Both Shaft Extensions Must Be Specified

HOUSING CONFIGURATION

F = Standard Flange Base

SCREW CONFIGURATION

TRANSLATING - U and I MODELS

T = Standard Threaded End
 C = Clevis End
 P = Top Plate

ROTATING - UR and IR MODELS

A = Travel Nut Position "A"
 B = Travel Nut Position "B"

UR - Upright Rotating IR - Inverted Rotating

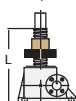

Travel Nuts shown in position "A"

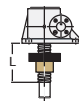

TRAVEL

TRANSLATING - U and I MODELS
 use actual Travel in inches.

ROTATING - UR and IR MODELS
 use "L" Dimension in Inches.

MODIFIER LIST

S or M Required

S = Standard. no additional description required
 M = Modified, additional description required

E, B and/or H Optional

E = In-Line Encoder (motor or motor mount required)
 B = Bellows Boots (must calculate retracted and extended boot length, see page 280-281)
 H = Hardened Worm

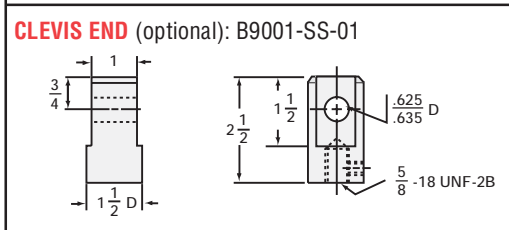
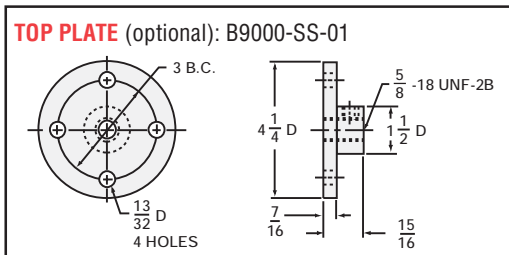
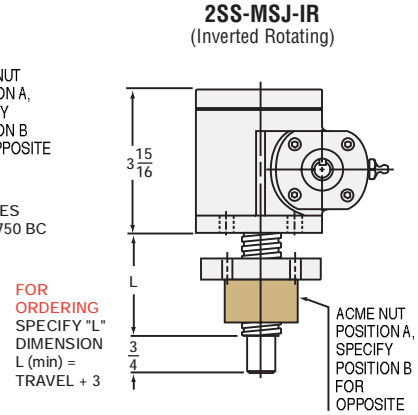
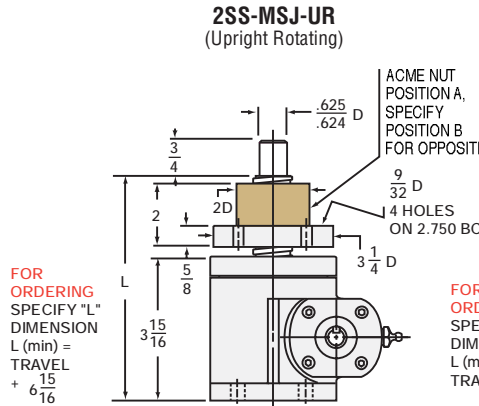
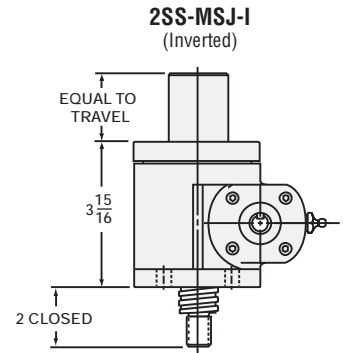
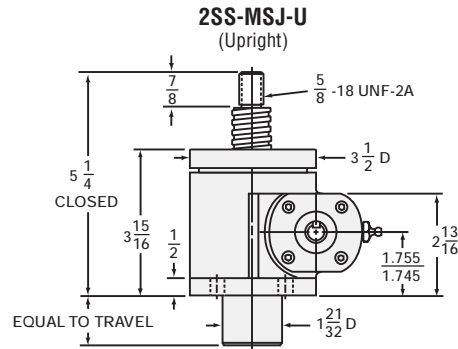
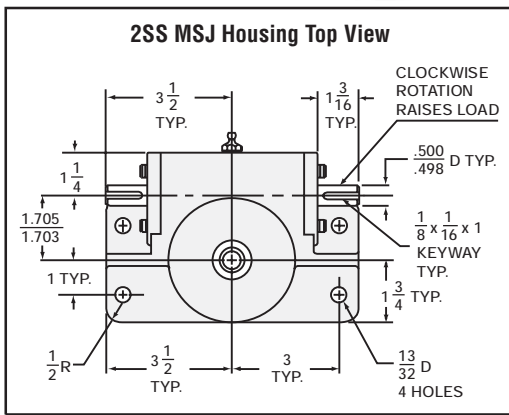

2SS-MSJ STANDARD SCREW

SCREW: 1 - 4
 ROOT DIAMETER: 0.698
 DRAG TORQUE: 4 IN.-LB.
 START TORQUE: 2 x Running Torque
 WEIGHT (Approx. in Pounds)
 "0" TRAVEL: 17
 PER INCH TRAVEL: .5
 GREASE: .5

RATIO	TURNS OF WORM PER INCH TRAVEL	TORQUE TO RAISE ONE LB.	MAX. HP	MAX. WORM SPEED AT RATED LOAD	MAX. LOAD AT 1750 RPM
6:1	24	.0250 in.-lbs.	2	1800 rpm	1330 lbs.
24:1	96	.0105 in.-lbs.	1/2	1800 rpm	1330 lbs.

LIFTING SCREW OR NUT MUST BE SECURED TO PREVENT ROTATION FOR NON-KEYED UNITS.
CAUTION! JACK MAY BE SELF-LOWERING IN SOME OPERATING CONDITIONS.

5SS MSJ Housing Top View

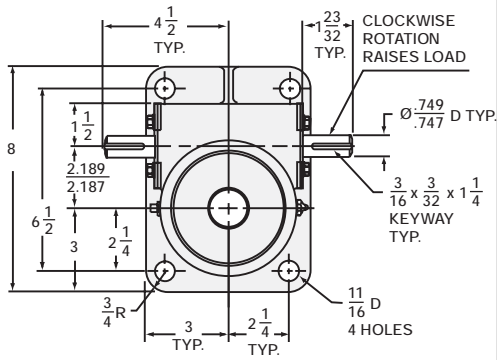

5SS-MSJ-U (Upright)

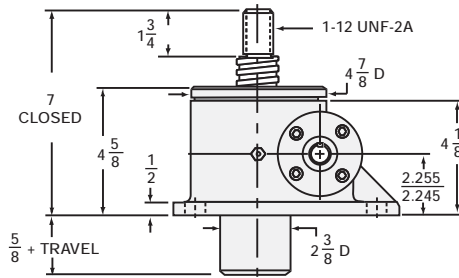

5SS-MSJ-I (Inverted)

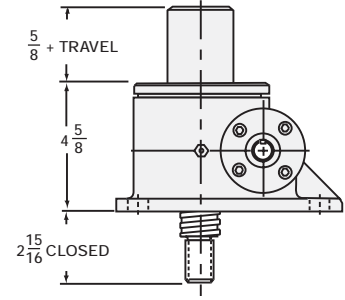

5SS-MSJ-UR (Upright Rotating)

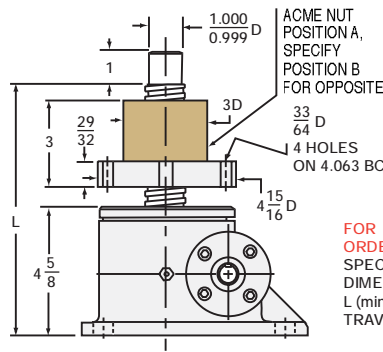

5SS-MSJ-IR (Inverted Rotating)

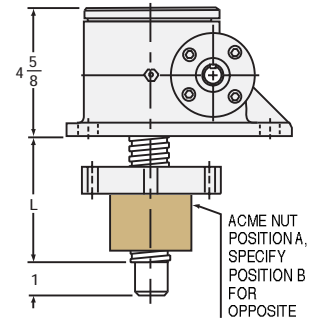

TOP PLATE (optional): B9000-SS-02

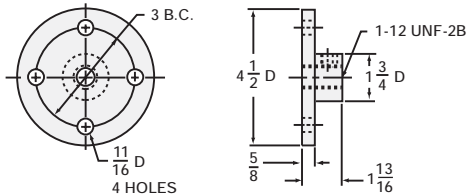

CLEVIS END (optional): B9001-SS-02

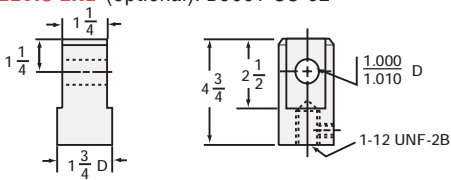

5SS-MSJ STANDARD SCREW

SCREW: $1\frac{1}{2}$ - 2 2/3
 ROOT DIAMETER: 1.066
 DRAG TORQUE: 10 IN.-LB.
 START TORQUE: 2 x Running Torque
 WEIGHT (Approx. in Pounds)
 "0" TRAVEL: 32
 PER INCH TRAVEL: .7
 GREASE: 1.00

RATIO	TURNS OF WORM PER INCH TRAVEL	TORQUE TO RAISE ONE LB.	MAX. HP	MAX. WORM SPEED AT RATED LOAD	MAX. LOAD AT 1750 RPM
6:1	16	.0376 in.-lbs.	3	1510 rpm	2873 lbs.
24:1	64	.0144 in.-lbs.	3/4	985 rpm	1875 lbs.

LIFTING SCREW OR NUT MUST BE SECURED TO PREVENT ROTATION FOR NON-KEYED UNITS.
CAUTION! JACK MAY BE SELF-LOWERING IN SOME OPERATING CONDITIONS.

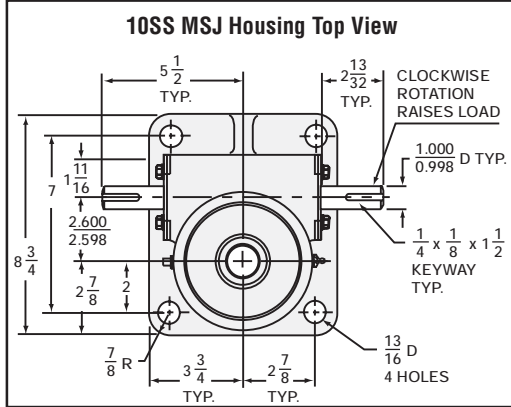

10SS-MSJ-U (Upright)

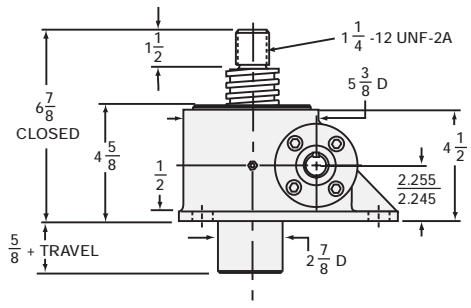

10SS-MSJ-I (Inverted)

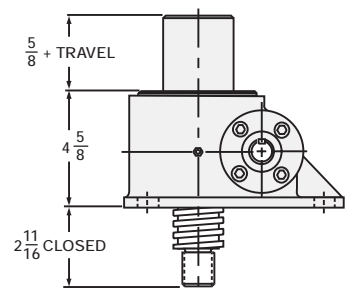

10SS-MSJ-UR (Upright Rotating)

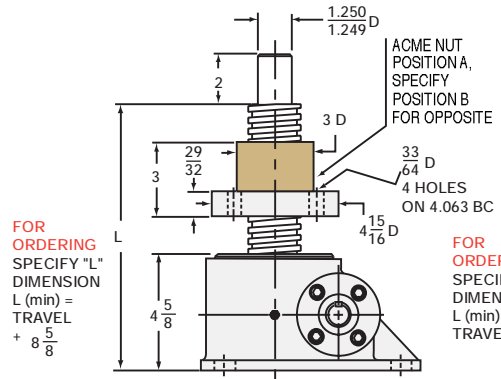

10SS-MSJ-IR (Inverted Rotating)

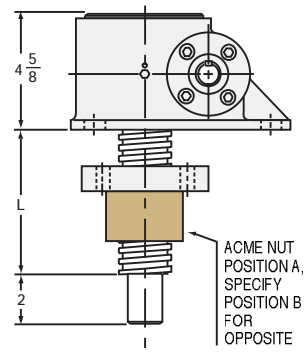

TOP PLATE (optional): B9000-SS-03

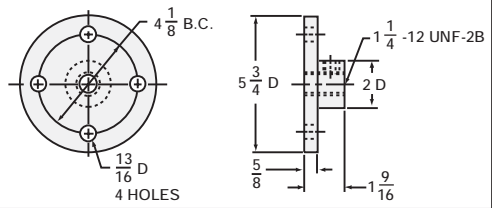

CLEVIS END (optional): B9001-SS-03

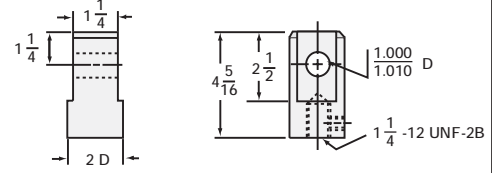

10SS-MSJ STANDARD SCREW

- SCREW: 2 - 2
- ROOT DIAMETER: 1.410
- DRAG TORQUE: 20 IN.-LB.
- START TORQUE: 2 x Running Torque
- WEIGHT (Approx. in Pounds)
- "0" TRAVEL: 50
- PER INCH TRAVEL: 1.2
- GREASE: 1.50

RATIO	TURNS OF WORM PER INCH TRAVEL	TORQUE TO RAISE ONE LB.	MAX. HP	MAX. WORM SPEED AT RATED LOAD	MAX. LOAD AT 1750 RPM
8:1	16	.0377 in.-lbs.	5	1255 rpm	4775 lbs.
24:1	48	.0192 in.-lbs.	1 1/2	739 rpm	2813 lbs.

LIFTING SCREW OR NUT MUST BE SECURED TO PREVENT ROTATION FOR NON-KEYED UNITS.
CAUTION! JACK MAY BE SELF-LOWERING IN SOME OPERATING CONDITIONS.

15SS MSJ Housing Top View

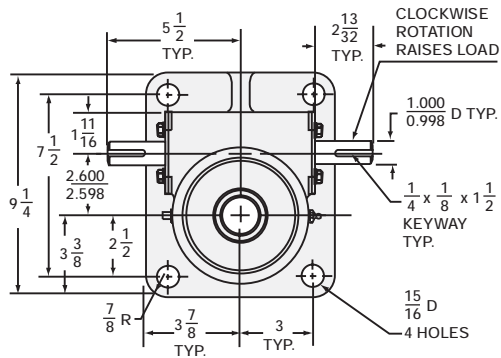

15SS-MSJ-U

(Upright)

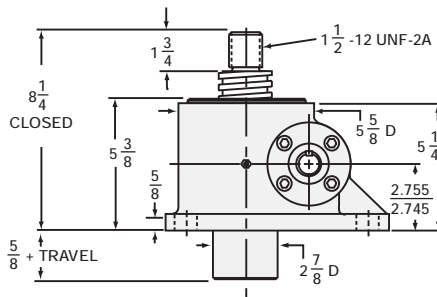

15SS-MSJ-I

(Inverted)

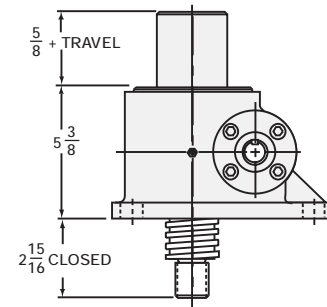

15SS-MSJ-UR

(Upright Rotating)

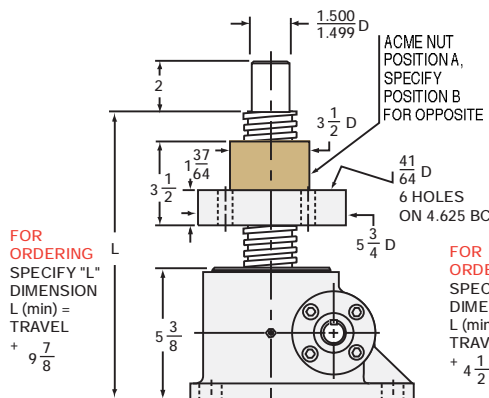

15SS-MSJ-IR

(Inverted Rotating)

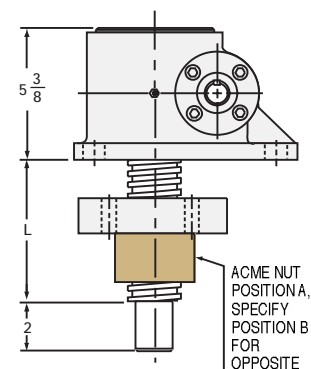

TOP PLATE (optional): B9000-SS-05

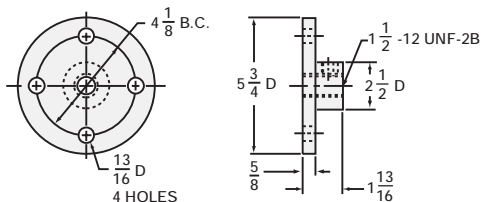

CLEVIS END (optional): B9001-SS-05

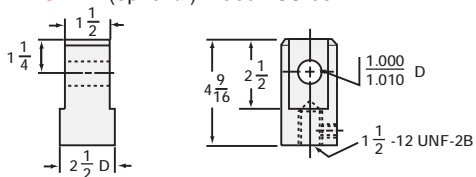

15SS-MSJ STANDARD SCREW

SCREW: 2 1/4 - 2

ROOT DIAMETER: 1.684

DRAG TORQUE: 20 IN.-LB.

START TORQUE: 2 x Running Torque

WEIGHT (Approx. in Pounds)

"0" TRAVEL: 60

PER INCH TRAVEL: 1.4

GREASE: 1.50

RATIO	TURNS OF WORM PER INCH TRAVEL	TORQUE TO RAISE ONE LB.	MAX. HP	MAX. WORM SPEED AT RATED LOAD	MAX. LOAD AT 1750 RPM
8:1	16	.0407 in.-lbs.	5	774 rpm	4424 lbs.
24:1	48	.0218 in.-lbs.	1 1/2	434 rpm	2478 lbs.

LIFTING SCREW OR NUT MUST BE SECURED TO PREVENT ROTATION FOR NON-KEYED UNITS.
CAUTION! JACK MAY BE SELF-LOWERING IN SOME OPERATING CONDITIONS.

20SS MSJ Housing Top View

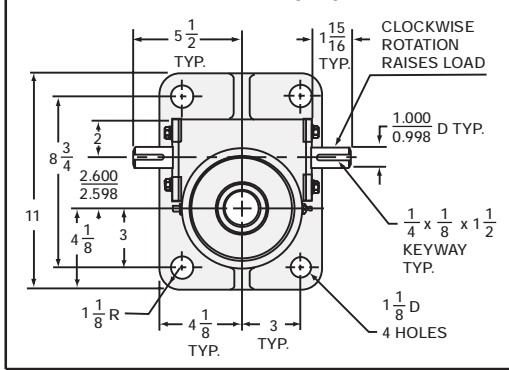

20SS-MSJ-U (Upright)

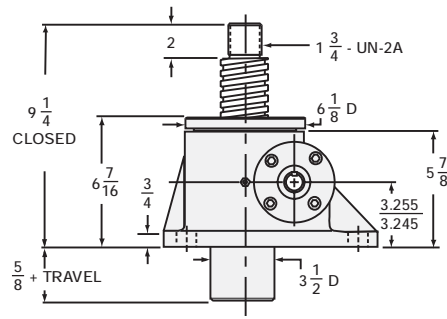

20SS-MSJ-I (Inverted)

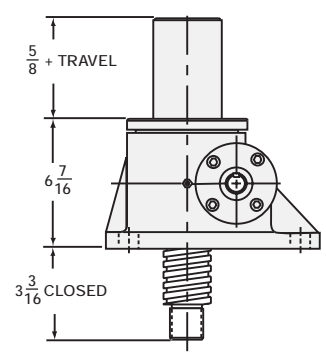

20SS-MSJ-UR (Upright Rotating)

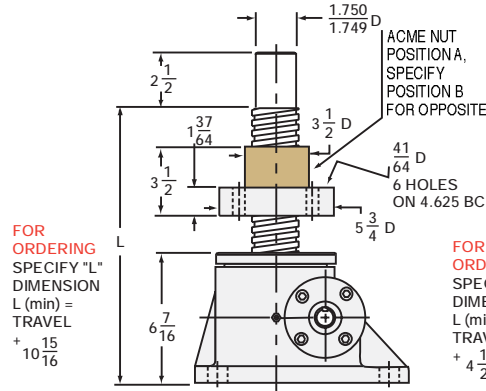

20SS-MSJ-IR (Inverted Rotating)

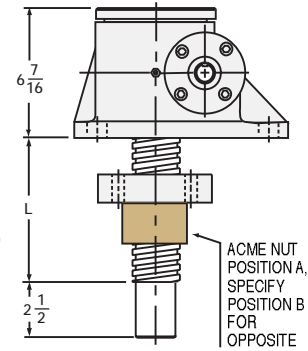

TOP PLATE (optional): B9000-SS-06

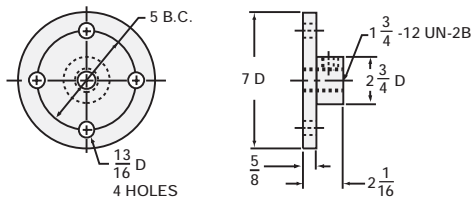

CLEVIS END (optional): B9001-SS-06

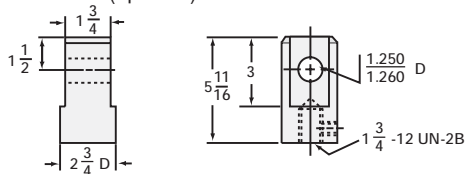

20SS-MSJ STANDARD SCREW

SCREW: $2\frac{1}{2}$ - 2
 ROOT DIAMETER: 1.908
 DRAG TORQUE: 40 IN.-LB.
 START TORQUE: 2 x Running Torque
 WEIGHT (Approx. in Pounds)
 "0" TRAVEL: 85
 PER INCH TRAVEL: 2.0
 GREASE: 2.25

RATIO	TURNS OF WORM PER INCH TRAVEL	TORQUE TO RAISE ONE LB.	MAX. HP	MAX. WORM SPEED AT RATED LOAD	MAX. LOAD AT 1750 RPM
8:1	16	.0435 in.-lbs.	5	540 rpm	4140 lbs.
24:1	48	.0218 in.-lbs.	11/2	325 rpm	2478 lbs.

LIFTING SCREW OR NUT MUST BE SECURED TO PREVENT ROTATION FOR NON-KEYED UNITS.
CAUTION! JACK MAY BE SELF-LOWERING IN SOME OPERATING CONDITIONS.

25SS MSJ Housing Top View

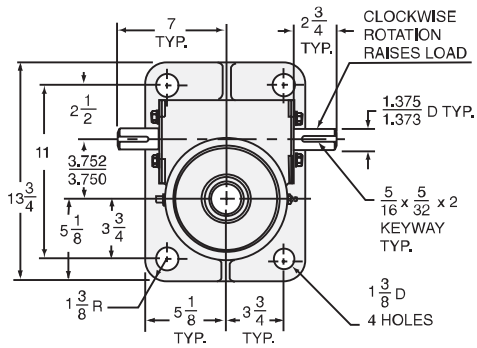

25SS-MSJ-U (Upright)

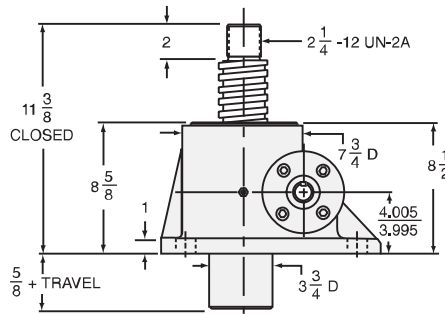

25SS-MSJ-I (Inverted)

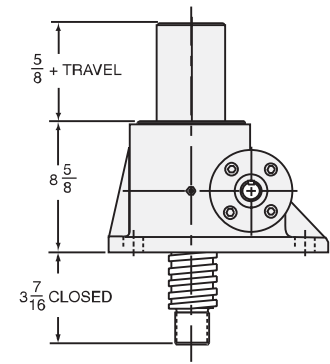

25SS-MSJ-UR (Upright Rotating)

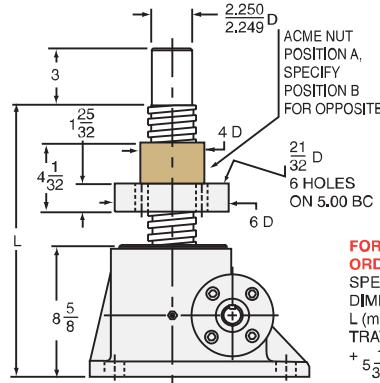

25SS-MSJ-IR (Inverted Rotating)

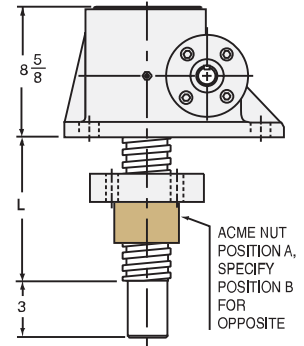

TOP PLATE (optional): B9000-SS-07

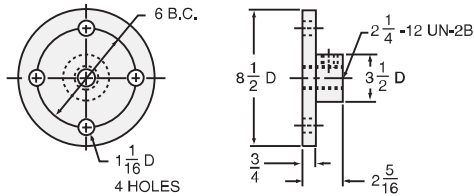

CLEVIS END (optional): B9001-SS-08

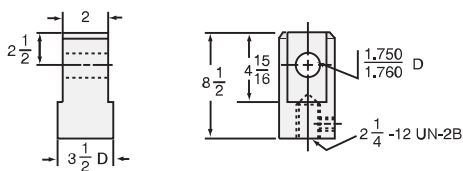

25SS-MSJ STANDARD SCREW

SCREW:	3 - 1 1/2
ROOT DIAMETER:	2.287
DRAG TORQUE:	50 IN.-LB.
START TORQUE:	2 x Running Torque
WEIGHT (Approx. in Pounds)	
"0" TRAVEL:	155
PER INCH TRAVEL:	3.1
GREASE:	3.50

RATIO	TURNS OF WORM PER INCH TRAVEL	TORQUE TO RAISE ONE LB.	MAX. HP	MAX. WORM SPEED AT RATED LOAD	MAX. LOAD AT 1750 RPM
10 2/3:1	16	.0452 in.-lbs.	11	768 rpm	7310 lbs.
32:1	48	.0235 in.-lbs.	3 1/2	468 rpm	4457 lbs.

LIFTING SCREW OR NUT MUST BE SECURED TO PREVENT ROTATION FOR NON-KEYED UNITS.
CAUTION! JACK MAY BE SELF-LOWERING IN SOME OPERATING CONDITIONS.

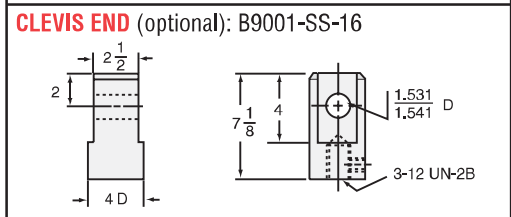
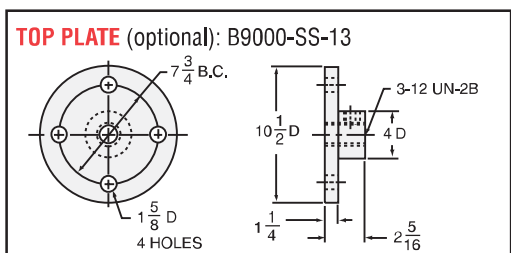
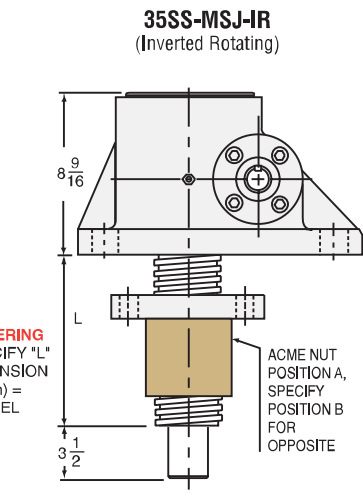
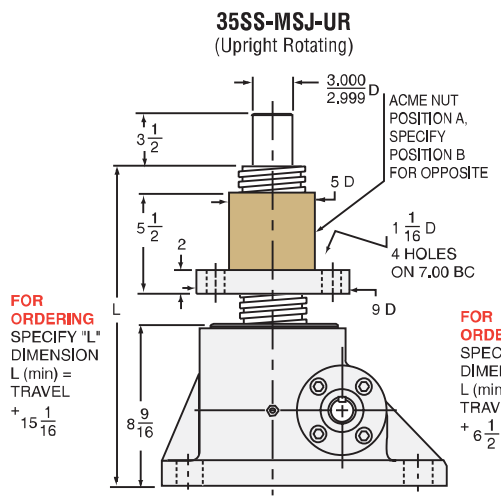
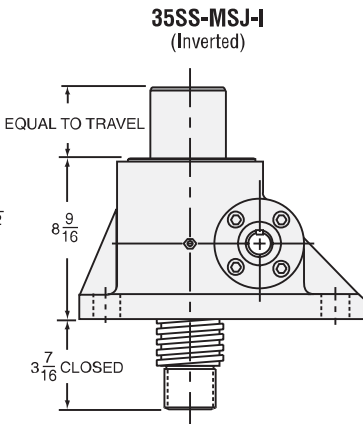
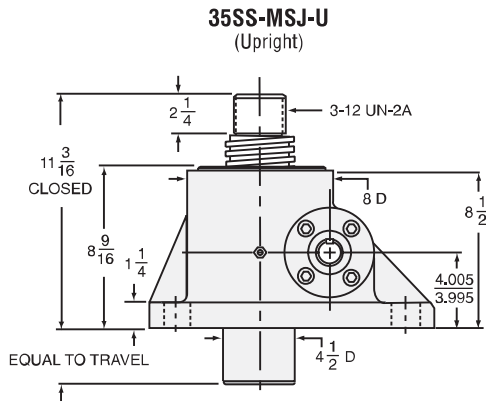
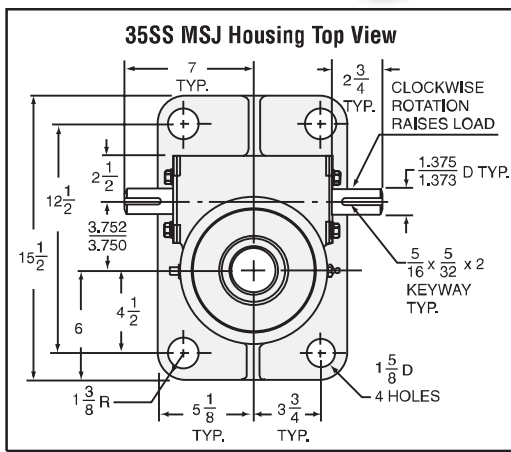

35SS-MSJ STANDARD SCREW
 SCREW: $3\frac{3}{4}$ - 1 1/2
 ROOT DIAMETER: 3.009
 DRAG TORQUE: 50 IN.-LB.
 START TORQUE: 2 x Running Torque
 WEIGHT (Approx. in Pounds)
 "0" TRAVEL: 165
 PER INCH TRAVEL: 3.5
 GREASE: 3.50

RATIO	TURNS OF WORM PER INCH TRAVEL	TORQUE TO RAISE ONE LB.	MAX. HP	MAX. WORM SPEED AT RATED LOAD	MAX. LOAD AT 1750 RPM
10 ² / ₃ :1	16	.0493 in.-lbs.	11	603 rpm	8035 lbs.
32:1	48	.0251 in.-lbs.	3 1/2	368 rpm	4906 lbs.

LIFTING SCREW OR NUT MUST BE SECURED TO PREVENT ROTATION FOR NON-KEYED UNITS.
CAUTION! JACK MAY BE SELF-LOWERING IN SOME OPERATING CONDITIONS.