



**ZERO-MAX**

**CD<sup>®</sup> Couplings**  
**SERIES A1C**





## ZERO-MAX CD® COUPLINGS SERIES A1C

- For today's most demanding servo motor and motion control applications. CD Couplings Series A1C are precise, robust, and available in sizes and models for every application.
- High torsional stiffness and high dynamic load capacity ensure reliable machine operation.
- Precise positioning under high speed reversing loads without fatigue for reliable 24/7 operation.
- Unique patented composite disc design provides misalignment capacity and long operational life.
- Clamp style hub design provides a superior method of shaft engagement.
- Eco-Friendly, adapted to RoHS Directive with no banned substances.



**These next-generation** CD Couplings Series A1C allow you to transmit high horsepower in a small envelope. They are ideal for cyclic applications where speed and repeatable accuracy are critical to keep 24/7 systems going.

**CD Couplings Series A1C** withstand the punishment and stress of a servo motor. In comparison, other couplings may have high torsional stiffness specifications; however, they can be too brittle to withstand the punishment of high speed reversing applications.

**The working part** of a CD Coupling Series A1C is made of high precision composite material. This patented design has high torsional stiffness, and yet allows for misalignment in high stress applications. CD Couplings Series A1C have excellent chemical and moisture resistance and operate without maintenance in hostile environments.



**Standard and Custom** CD Couplings Series A1C are available for every application. Do you need higher misalignment and greater torque capacity in your coupling? Need more flexibility and torsional stiffness? Need a very large bore diameter coupling? Or a long spacer coupling? Zero-Max CD Couplings Series A1C are available in a full range of styles, models and sizes to meet those needs. Zero-Max will design and build a custom CD Coupling Series A1C to handle your unique application.



## CD® COUPLINGS SERIES A1C FOR THE MOST DIFFICULT MOTION APPLICATIONS

- Ideal for high precision applications including packaging machines, pick and place systems, printing machinery, machine tools and most systems using servo motors.
- Operating temperature range is -70° to +250° F (-57° to +121° C).
- Composite discs are resistant to many chemicals.
- Maintenance free.
- Hubs are machined to a high level of concentricity for smooth and quiet operation.
- RoHS compliant – manufactured of RoHS compliant materials and contains no banned substances.

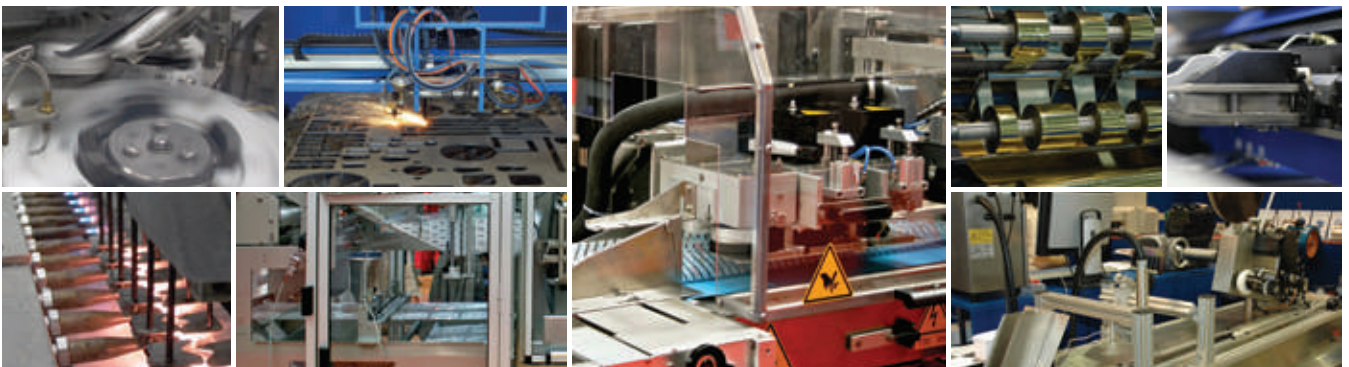



## CD® COUPLINGS **SINGLE FLEX** ALUMINUM

CD Coupling Series A1C has very low weight and inertia, making it an excellent choice for servo motor applications. The unique design delivers two features that are not often found in a precision coupling. High torsional stiffness and high durability!

The compact size, low inertia, and clamping system enable this coupling to fit into many applications.

- Zero Backlash
- Torsionally Stiff
- Excellent for Reversing Loads
- Smooth Operation at High Speeds
- Compact



### Performance Information

Model	Continuous Torque	Peak Torque	Torsional Stiffness	Maximum Speed	Maximum Misalignments			Weight		Inertia	
					Angular	Parallel	Axial	Max Bore	Min Bore	Max Bore	Min Bore
	Nm	Nm	Nm/Rad	RPM	Degrees	mm	mm	kg	kg	10 <sup>-3</sup> kg-m <sup>2</sup>	10 <sup>-3</sup> kg-m <sup>2</sup>
6A18-A1C	20	40	11,650	15,000	2	0.1	0.8	0.2	0.26	0.088	0.095
6A22-A1C	30	60	17,352	13,500	2	0.15	0.9	0.33	0.41	0.19	0.21
6A26-A1C	53	106	20,100	11,500	2	0.2	1.1	0.46	0.6	0.35	0.37
6A30-A1C	90	180	42,976	9,500	2	0.25	1.3	0.76	0.94	0.78	0.82
6A37-A1C	181	362	67,167	8,000	2	0.33	1.8	1.59	2.04	2.53	2.71
6A45-A1C	282	564	123,909	6,700	2	0.38	2.3	3	3.9	7.16	7.71

- Consult factory for speeds higher than those listed and balancing requirements, if necessary.
- Consult factory for higher torque and higher torsional stiffness couplings.
- Available with or without keyway on clamp style hubs.



## CD® COUPLINGS **SINGLE FLEX** ALUMINUM

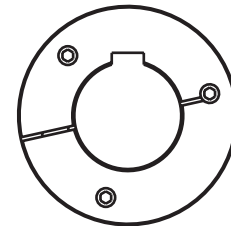
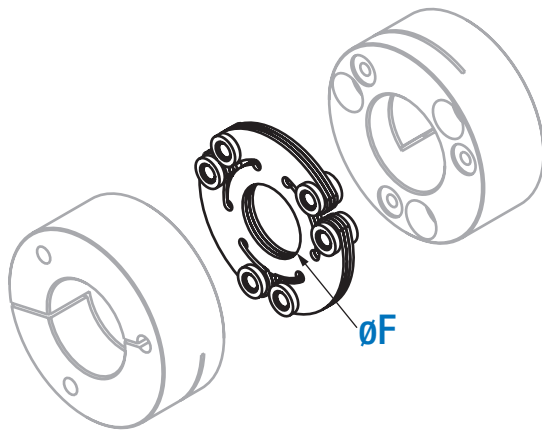
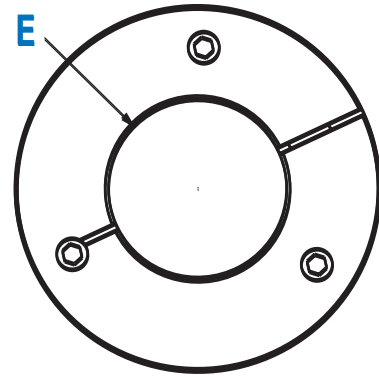
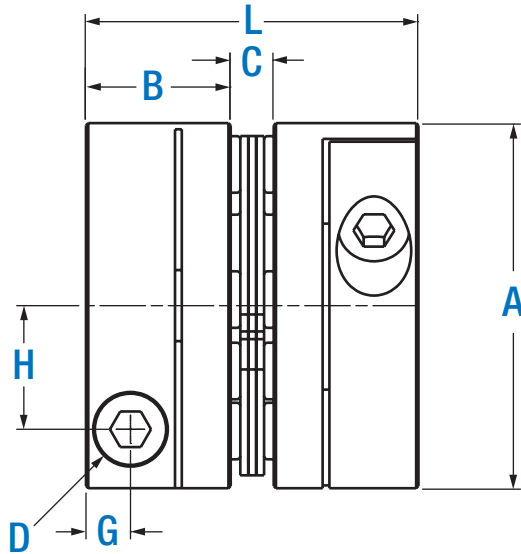

Note: Typical keyway placement

### Dimensional Information

Model	A	B	C	D		E (bore)		F	G	H	L
				Bolt	Torque	Min	Max				
	mm	mm	mm	M	Nm	mm	mm	mm	mm	mm	mm
6A18-A1C	53	22.5	5.49	M6	13	9	27	20.1	7.25	18	50.5
6A22-A1C	62	26	5.74	M6	13	16	31	24.9	7.24	22	57.7
6A26-A1C	69.5	29.5	6.25	M8	32	14	36	25.4	9.14	24	65.2
6A30-A1C	82	32.5	9.65	M10	58	16	40	30.71	10	27.8	74.7
6A37-A1C	101	46	11.23	M12	100	18	52	38.4	12.7	36	103.2
6A45-A1C	123	60	12.75	M16	245	24	65	46	16.95	43.5	132.8



## CD® COUPLINGS **DOUBLE FLEX** ALUMINUM

CD Coupling Series A1C has very low weight and inertia, making it an excellent choice for servo motor applications. The unique design delivers two features that are not often found in a precision coupling. High torsional stiffness and high durability!

The compact size, low inertia, and clamping system enable this coupling to fit into many applications.



- Zero Backlash
- Torsionally Stiff
- Excellent for Reversing Loads
- Smooth Operation at High Speeds
- Compact

### Performance Information

Model	Continuous Torque	Peak Torque	Torsional Stiffness	Maximum Speed	Maximum Misalignments			Weight		Inertia	
					Angular	Parallel	Axial	Max Bore	Min Bore	Max Bore	Min Bore
	Nm	Nm	Nm/Rad	RPM	Degrees	mm	mm	kg	kg	10 <sup>-3</sup> kg-m <sup>2</sup>	10 <sup>-3</sup> kg-m <sup>2</sup>
6P18-A1C	20	40	5,500	15,000	2	0.44	1.6	0.25	0.30	0.30	0.11
6P22-A1C	30	60	8,482	13,500	2	0.58	1.8	0.39	0.47	0.22	0.24
6P26-A1C	53	106	9,712	11,500	2	0.55	2.2	0.54	0.65	0.41	0.43
6P30-A1C	90	180	20,923	9,500	2	0.85	2.6	0.97	1.14	1.00	1.10
6P37-A1C	181	362	32,700	7,900	2	1.00	3.6	2.03	2.43	3.17	3.31
6P45-A1C	282	564	60,324	6,700	2	1.24	4.6	3.7	4.6	8.50	9.00

- Consult factory for speeds higher than those listed and balancing requirements, if necessary.
- Consult factory for higher torque and higher torsional stiffness couplings.
- Available with or without keyway on clamp style hubs.



## CD® COUPLINGS **DOUBLE FLEX** ALUMINUM

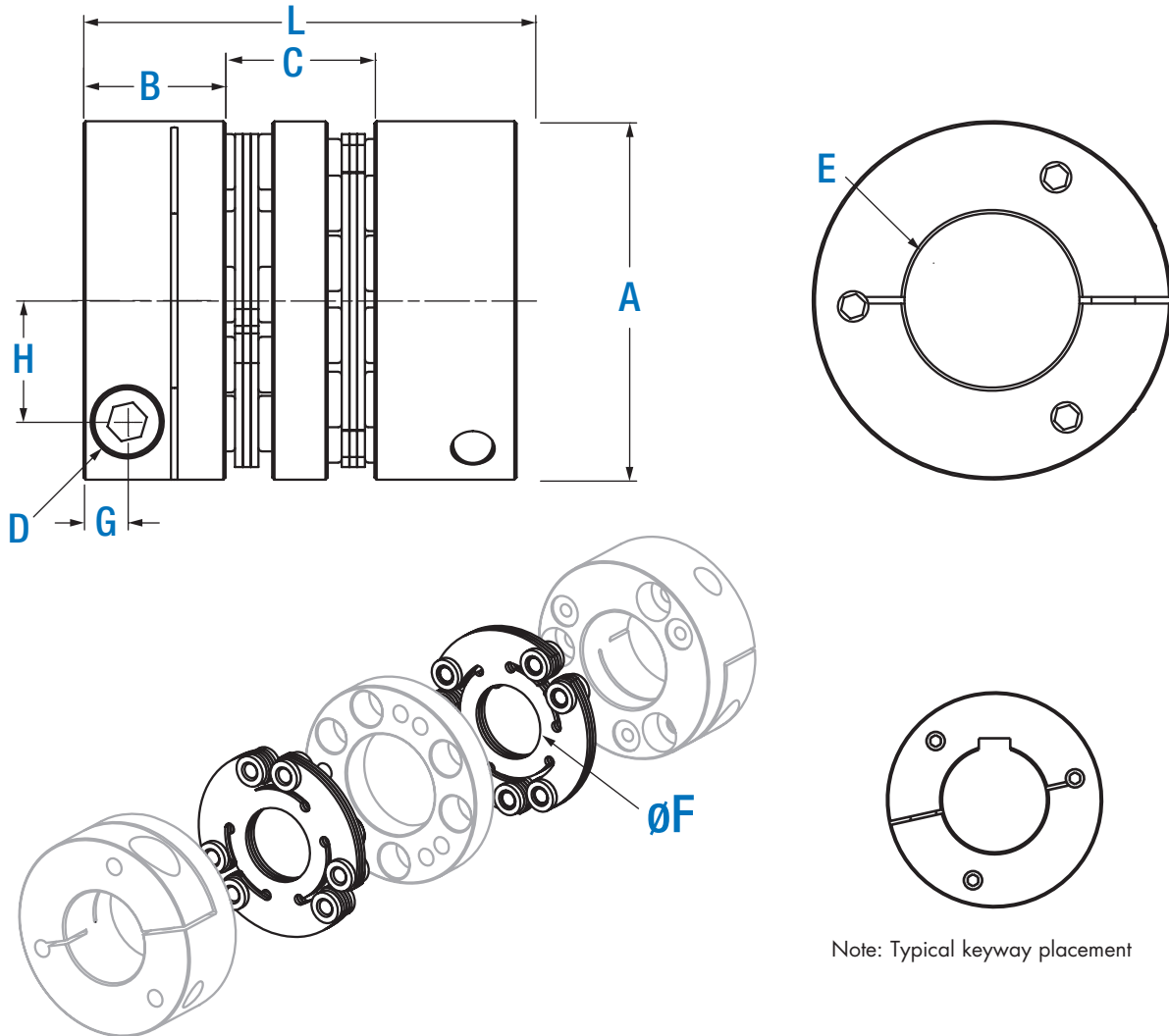

Note: Typical keyway placement

### Dimensional Information

Model	A	B	C	D		E (bore)		F	G	H	L
				Bolt	Torque	Min	Max				
	mm	mm	mm	M	Nm	mm	mm	mm	mm	mm	mm
6P18-A1C	53	22.5	18	M6	13	8	26	20.1	7	18	63
6P22-A1C	62	26	23	M6	13	12	31	24.9	7	22	75
6P26-A1C	69.5	29.5	22	M8	32	14	35	25.4	9.14	24	81
6P30-A1C	82	32.5	34	M10	58	16	40	30.7	10	27.8	99
6P37-A1C	101	46	42	M12	100	18	51	38.4	12.7	36	134
6P45-A1C	123	60	48	M16	245	24	65	46	16.2	43.5	168

## SELECTING A **CD**<sup>®</sup> COUPLING

### Feed Screw Systems

#### 1. Oscillation phenomena of servomotors

If the resonant frequency of the entire feed-screw system is under 400~500Hz, oscillation may occur depending on the gain adjustment of the servomotor. The problems can be avoided by raising the resonant frequency of the mechanical system or adjusting the tuning function (filter function) of the servomotor.

Contact us for unclear points concerning oscillation phenomena of servomotors.

### How to evaluate the resonant frequency of feed-screw system

1. Select the coupling according to the normal operating torque and maximum torque of the servomotor/stepping motor.
2. In the following feed-screw system, evaluate the entire resonant frequency: Nf from the torsional spring constant: K of the coupling and feed screw, the moment of inertia: J1 of the driving side and the moment of inertia: J2 of the driven side.

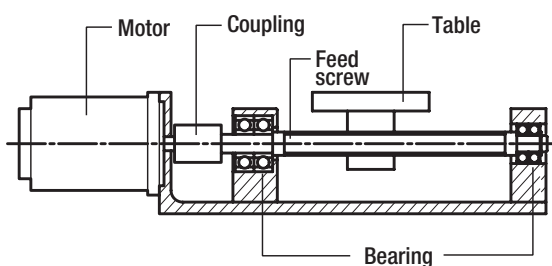

$$Nf = \frac{1}{2\pi} \sqrt{K \left( \frac{1}{J1} + \frac{1}{J2} \right)}$$

Nf: Eigenfrequency of the entire feed-screw system [Hz]

K: Torsional spring constant of the coupling and feed screw [N · m/rad]

J1: Moment of inertia of the driving side

J2: Moment of inertia of the driven side

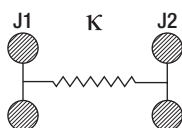

### Selection Procedure

1. Calculate torque Ta applied to the coupling based on the motor output P and coupling operating rotation speed n.

$$Ta[N \cdot m] = 9550 \times \frac{P [kW]}{n [min^{-1}]}$$

2. Calculate corrected torque Td applied to the coupling after deciding the service factor K based on load conditions.

$$Td = Ta \times K$$

In servomotor drive, multiply the service factor K=1.2~1.5 by the maximum torque of servomotor Ts.

$$Td = Ts \times (1.2 \sim 1.5)$$

3. Select a coupling size with permissible torque Tn that becomes greater than the corrected torque Td.

$$Tn \geq Td$$

4. Depending on the bore diameters, the coupling permissible torque may be limited. Refer to the "Specification" and "Standard bore diameter".

5. Confirm if the required shaft diameter does not exceed the maximum bore diameter of the selected size.

### Custom Designs Available Upon Request

If our standard line of couplings will not exactly fit your system needs, contact us for a custom design.

- Custom bores
- Ultra high speeds
- Special finishes
- Special Lengths
- Designed for operation in special environments



## CD® HOW TO ORDER

### Part Numbering Structure

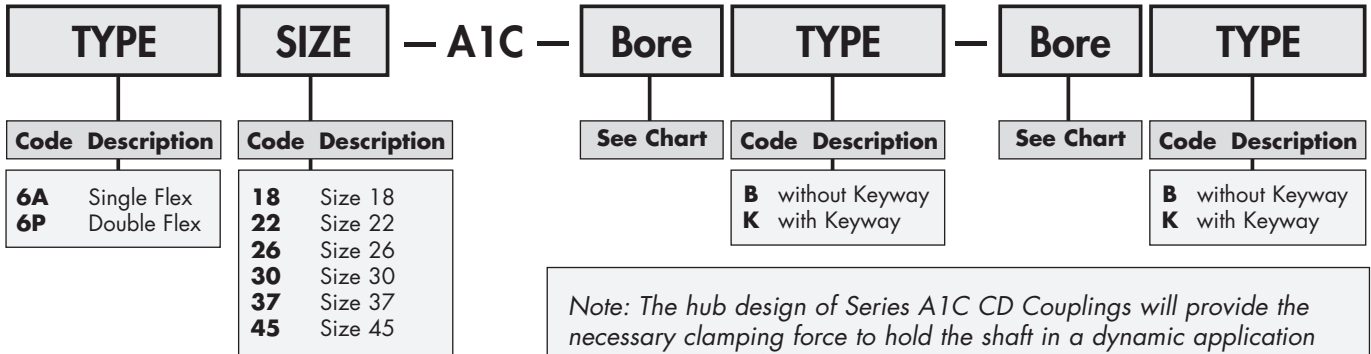

Note: The hub design of Series A1C CD Couplings will provide the necessary clamping force to hold the shaft in a dynamic application without the use of keyways.

**Example:**  
**6A30-A1C-20B-28B**

- Single Flex
- Size 30
- 20mm bore without keyway x 28mm bore without keyway

### Bore Size

Model	Bore (mm)	9	10	11	12	13	14	15	16	17	18	19	20	22	24	25	28	30	32	35	38	40	42	45	48	50	52	55	58	60	62	63	65	
6A18-A1C 6P18-A1C		●	●	●	●	●	●	●	●	●	●	●	●	●	●	●																		
6A22-A1C 6P22-A1C									●	●	●	●	●	●	●	●	●	●	●															
6A26-A1C 6P26-A1C							●	●	●	●	●	●	●	●	●	●	●	●	●	●	●													
6A30-A1C 6P30-A1C									●	●	●	●	●	●	●	●	●	●	●	●	●	●	●											
6A37-A1C 6P37-A1C											●	●	●	●	●	●	●	●	●	●	●	●	●	●	●	●	●							
6A45-A1C 6P45-A1C															●	●	●	●	●	●	●	●	●	●	●	●	●	●	●	●	●	●	●	●

●: The coupling will transmit full peak torque on a shaft without a keyway. Please contact the factory for additional bores

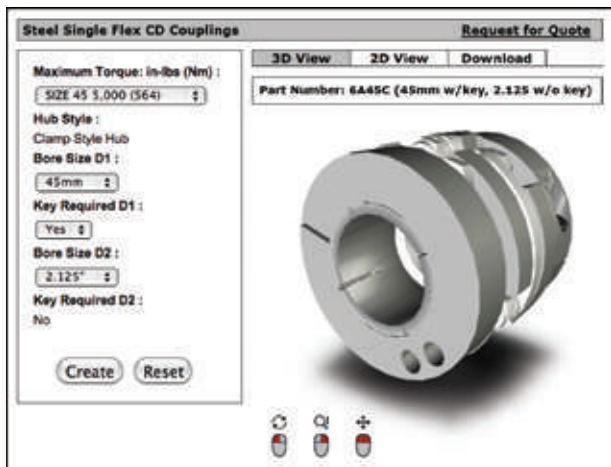

New Zero-Max Configurable 3D CAD Downloads.  
[www.zero-max.com](http://www.zero-max.com)



## GLOBAL SUPPORT



**////// ZERO-MAX®**

Haarup Tvaer Vej # 1, Silkeborg, DK8600, Denmark  
Phone: +45 8681 2288 Fax +45 8681 5388  
[www.zero-max.dk](http://www.zero-max.dk) Email [ext@zero-max.dk](mailto:ext@zero-max.dk)