

Airflex® EB and ER Construction



EB Element



ER Element

EB elements are suited to slow speed applications having moderate starting and stopping loads. They are used as slip clutches and tension brakes for lighter torque and horsepower applications.

EB elements are similar in design and construction to the CB elements and have many of the CB features. A neoprene rubber and cord tube is bonded on its inside diameter to a cylindrical surface. Friction shoes are attached with pins and held in position with lockwires to the outside diameter of the tube. Torque is transmitted by the sidewalls of the rubber tube. Pressurizing the tube forces the friction shoes to engage an inside drum diameter.

The expanding design allows the element to behave as a centrifugal clutch. The radial stiffness of the rubber tube determines the element speed at which the friction shoes will retract.

The rubber tubes of the three small elements are bonded to the outside diameters of solid hubs, which, in turn, are bored and keyseated for direct shaft mounting. The pressurizing passage can be either a radial hole thru the hub or a port provided in the hub face. Larger element sizes are attached to the shaft by a separate element hub.

Element torque is dependent upon the applied pressure and speed. Catalog ratings are given at 75 psi (5,2) and zero rpm. Maximum recommended pressure is 110 psi (7,6 bar). Adjustment for operating pressure and speed is explained under Selection Procedure.

EB elements are available in 11 sizes. They are identified by the inside drum diameter in inches to which they expand and the width in inches of their friction lining. For instance, size 16EB475 is designed to expand to a 16 inch diameter drum and has a friction lining width of 4.75 inches. The smallest EB element will expand to a 4 inch (102 mm) diameter drum and the largest to a 24 inch (610 mm) diameter drum. Due to its small diameter, the 4EB125 does not have replaceable friction shoes. Instead, the friction material is bonded to its rubber tube.

Construction of the ER element is similar to the EB element, except for friction shoes. ER elements engage their drums directly with the outside rubber surface of their actuating tubes. This interface results in a friction force which provides a large torque in a relatively small package. It also provides electrical isolation between connecting shafts.

ER elements are used as shaft couplings or holding brakes where engagement occurs at zero speed differential between element and drum. They are ideal for applications in which a disconnect is required without stopping the prime mover or in which the driving and or driven equipment must be frequently withdrawn from the drive.

ER elements are identified similar to the EB elements. They are available in ten sizes. The smallest expands to a 3 inch (51 mm) diameter drum and the largest to a 24 inch (610 mm) diameter drum.

Where Used:

- Centrifuges
- Core Expanders
- Laundry Machines
- Textile Machines
- Tire Building Machines

Airflex® EB Components Descriptions

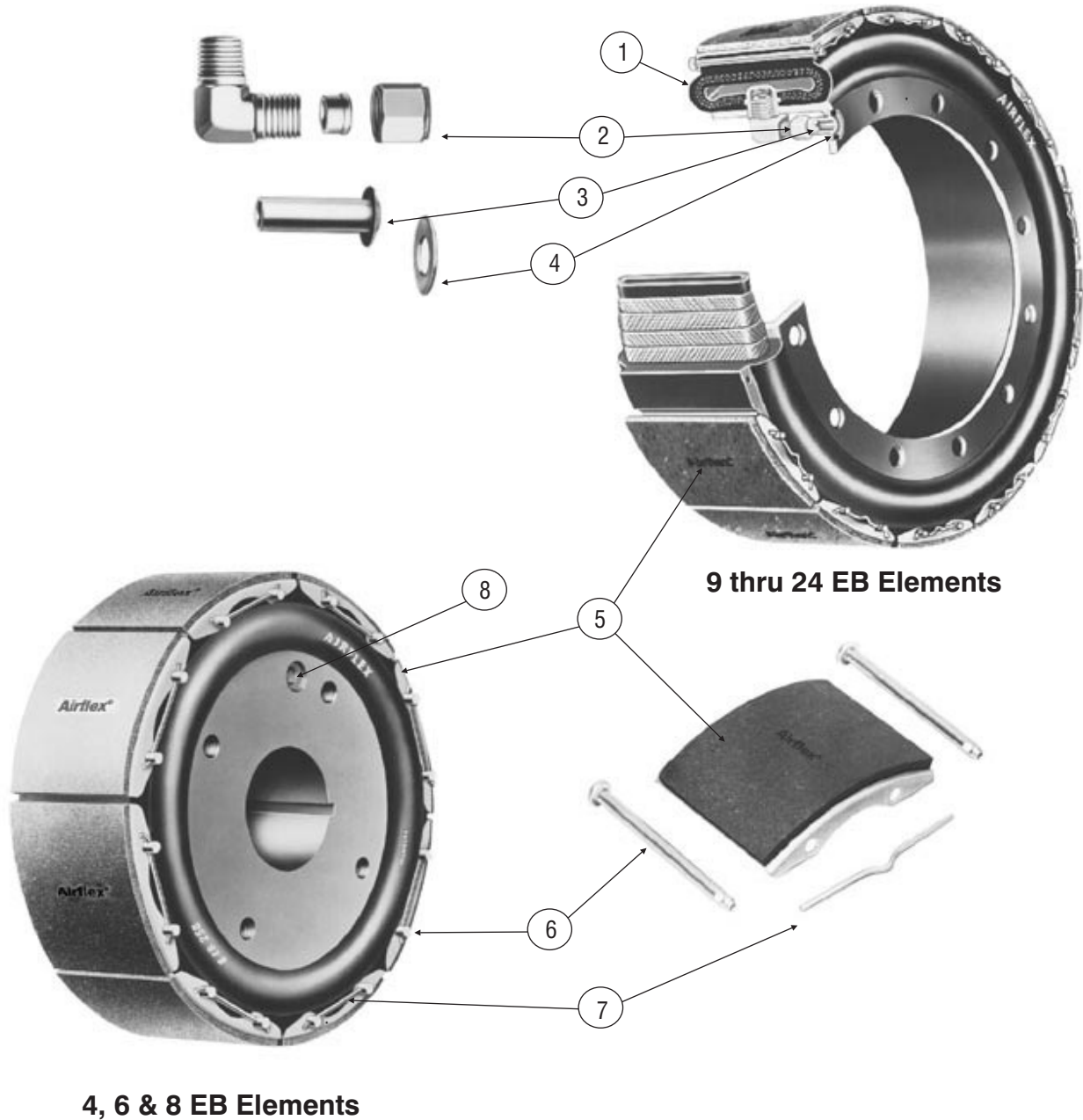

9 thru 24 EB Elements

4, 6 & 8 EB Elements

Size	Torque Rating	
	English	SI
	lb in @ 75 psi	Nm @ 5,2 bar
4EB125	390	44,1
6EB200	910	103
8EB250	2220	251
9EB325	3750	424
10EB300	4275	483
12EB350	7500	848
14EB400	12000	1360
16EB475	18750	2120
19EB475	27000	3050
21.5EB475	36000	4070
24EB475	45000	5090

Size	Torque Rating	
	English	SI
	lb in @ 75 psi	Nm @ 5,2 bar
3ER125	400	45,2
6ER200	1540	174
8ER250	3550	401
10ER300	6600	746
12ER350	12300	1390
14ER400	22600	2550
16ER475	32600	3680
19ER475	47600	5380
21.5ER475	63000	7120
24ER475	83500	9440

Item	Component Description
1	Rim or hub and tube assembly
2	Elbow assembly
3	Air connection tube
4	Air connection gasket
5	Friction shoe
6	Shoe pin
7	Lockwire
8	Pipe plug
5,6,7	Friction shoe, pin and lockwire kit

Airflex® EB Elements



Form EB 701

Dimensional and Technical Data Sizes 4 to 8

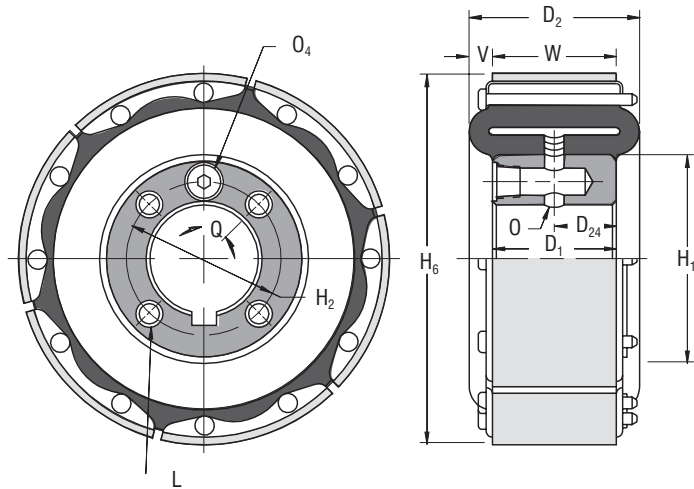

English		lbin @ 75 psi	Dimensions in inches															
4EB125	143019	390	0.88	1.50	1.50	1.75	0.75	2.12	3.94	2.75	4	5/16-18	0.31	1/4-18	45.0	0.25	10	1.25
6EB200	143022	910	0.88	1.75	2.00	2.75	1.00	2.50	5.91	3.38	4	3/8-16	0.31	1/4-18	45.0	0.38	6	2.00
8EB250	143117	2220	1.25	3.50	2.50	3.25	1.25	4.38	7.84	5.38	4	3/8-16	0.31	1/8-27	22.5	0.38	8	2.50
Size	Part Number	M _t Torque Rating	Bore Range		D ₁	D ₂	D ₂₄	H ₂	H ₆	H ₁₃	No. Size		O	O ₄	Q (Deg)	V	No. Width	
			Min.	Max.							L	Size					No.	Width
			Min.	Max.														
4EB125	143019	44,1	22	38	38	44	19	54	100	70	4	5/16-18	8	1/4-18	45,0	6	10	32
6EB200	143022	103	22	44	51	70	25	64	150	86	4	3/8-16	8	1/4-18	45,0	10	6	51
8EB250	143117	251	32	89	64	83	32	111	199	137	4	3/8-16	8	1/8-27	22,5	10	8	64
SI		Nm @ 5,2 bar	Dimensions in millimeters															

English		lbin @ 75 psi	rpm	psi/rpm ²	lb ft ²	lb	in ²	inches		in ³	in
4EB125	143019	390	1800	*	0.01	2.3	13	⑥	⑥	5	4.09
6EB200	143022	910	1800	1.1	0.25	7	36	0.14	0.06	10	6.09
8EB250	143117	2220	1800	1.2	1.00	19	60	0.12	0.06	15	8.09
Size	Part Number	M _t Torque Rating	Maximum Speed	C _s Centrifugal Gain	Wk ²		Friction Area	New Worn		Air Tube Cavity	Maximum Drum Diameter
					J	⑤ Mass		Lining Thickness			
								New	Worn		
4EB125	143019	44,1	1800	*	0,004	1,0	84	⑥	⑥	0,08	104
6EB200	143022	103	1800	0,1	0,11	3,2	232	4	2	0,16	155
8EB250	143117	251	1800	0,1	0,45	8,6	387	3	2	0,25	205
SI		Nm @ 5,2 bar	rpm	bar/rpm ²	kg·m ²	kg	cm ²	millimeters		dm ³	mm

Notes:

- ① Refers to basic part number only. When ordering, it must be specified which air entry hole, O or O₄ is to be used.
- ② Dynamic torque shown, static torque approximately 25% greater. Torque in each application is dependent upon air pressure and speed.
- ③ American National Standard for Unified Screw Threads.
- ④ American National Pipe Thread
- ⑤ Based upon minimum bores.
- ⑥ Lining molded into rubber tube. Complete element should be replaced when dimension H₆ is worn to 3.88 in (98 mm) diameter.
- ⑦ Drum contact with worn shoes.

Airflex® EB Element



Form EB 702

Technical Data Sizes 9 to 24

English		lb in @ 75 psi	rpm	psi/rpm ²	lb ft ²	lb	in ²	inches		in ³	in
9EB325	143274	3750	1800	1.6 E-06	1	9	88	0.20	0.06	30	9.09
10EB300	143119	4275	1800	2.2 E-06	1	10	91	0.20	0.06	47	10.09
12EB350	143122	7500	1800	3.4 E-06	3	16	126	0.20	0.06	45	12.09
14EB400	143126	12000	1500	4.3 E-06	5	23	167	0.20	0.06	55	14.09
16EB475	143129	18750	1300	6.4 E-06	11	40	232	0.26	0.06	195	16.13
19EB475	143131	27000	1100	10 E-06	20	49	270	0.26	0.06	235	19.13
21.5EB475	143134	36000	1000	13 E-06	34	62	306	0.26	0.06	280	21.63
24EB475	143137	45000	900	20 E-06	39	68	344	0.26	0.06	315	24.63

Size	① Part Number	② M, Torque Rating	Maximum Speed	C _s Centrifugal Gain	Wk ²		Friction Area	Lining Thickness		④ Max. Air Cavity	Max. Drum Diameter
					J	Mass		New	Worn		
								New	Worn		
9EB325	143274	424	1800	0,1 E-06	0,042	4,1	568	5	2	0,49	231
10EB300	143119	483	1800	0,2 E-06	0,042	4,5	587	5	2	0,77	256
12EB350	143122	848	1800	0,2 E-06	0,126	7,2	813	5	2	0,74	307
14EB400	143126	1360	1500	0,3 E-06	0,210	10	1077	5	2	0,90	358
16EB475	143129	2120	1300	0,4 E-06	0,462	18	1496	7	2	3,20	410
19EB475	143131	3050	1100	0,7 E-06	0,840	22	1742	7	2	3,85	486
21.5EB475	143134	4070	1000	0,9 E-06	1,43	28	1974	7	2	4,59	549
24EB475	143137	5090	900	1,4 E-06	1,64	31	2219	7	2	5,17	626

SI		Nm @ 5,2 bar	rpm	bar/rpm ²	kg m ²	kg	cm ²	millimeters		dm ³	mm
----	--	-----------------	-----	----------------------	-------------------	----	-----------------	-------------	--	-----------------	----

Notes:

- ① Refers to basic part number only.
- ② Dynamic torque shown, static torque approximately 25% greater. Torque in each application is dependent upon air pressure and speed.
- ③ Tolerances for sizes:
9 thru 14
+0.005/-0.000 in (0,13/-0,00 mm)
16 thru 24
+0.010/-0.000 in (0,25/-0,00 mm)
- ④ Drum contact with worn shoes.

Airflex® EB Elements



Form EB 702

Dimensional Data

Sizes 9 to 24

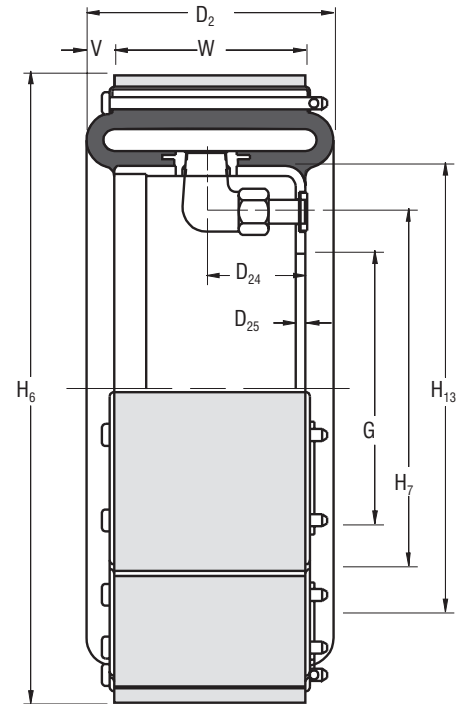
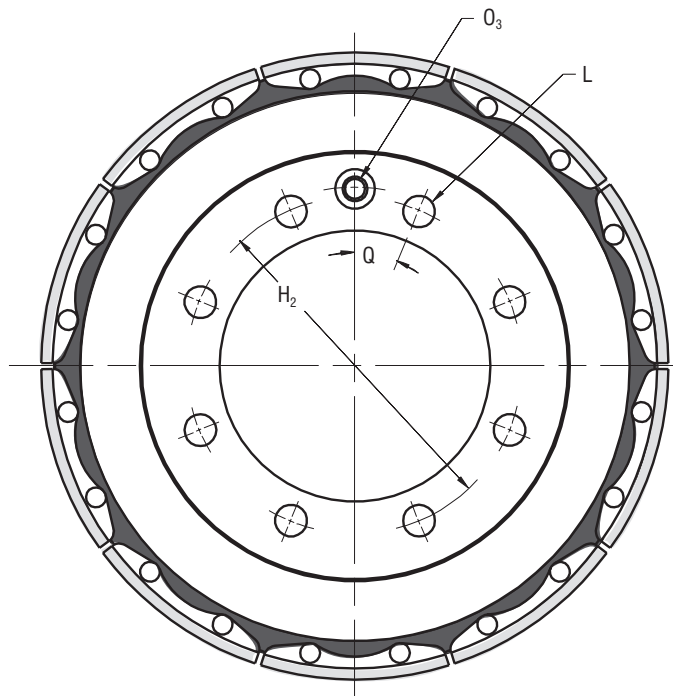

English		lb in @ 75 psi	Dimensions in inches														
9EB325	143274	3750	4.13	1.86	0.19	3.500	4.62	8.84	4.62	6.00	8	0.50	0.31	22.5	0.44	9	3.25
10EB300	143119	4275	3.88	1.56	0.16	4.250	5.25	9.84	5.56	7.00	8	0.50	0.31	22.5	0.44	10	3.00
12EB350	143122	7500	4.38	1.88	0.19	6.250	7.25	11.84	7.56	9.00	12	0.50	0.31	15.0	0.44	12	3.50
14EB400	143126	12000	4.88	1.88	0.19	8.250	9.25	13.84	9.56	11.00	12	0.50	0.31	15.0	0.44	14	4.00
16EB475	143129	18750	6.38	2.50	0.25	8.250	9.63	15.81	9.62	11.38	8	0.50	0.38	22.5	0.81	12	4.75
19EB475	143131	27000	6.38	2.50	0.25	9.625	11.00	18.81	11.00	14.38	6	0.75	0.38	30.0	0.81	14	4.75
21.5EB475	143134	36000	6.38	2.50	0.31	12.125	13.50	21.31	13.50	16.88	8	0.75	0.38	22.5	0.81	16	4.75
24EB475	143137	45000	6.38	2.50	0.31	14.625	16.00	23.81	16.00	19.38	8	0.75	0.38	22.5	0.81	18	4.75
Size	① Part Number	② M _t Torque Rating	D ₂	D ₂₄	D ₂₅	③ G	H ₂	H ₆	H ₇	H ₁₃	No. Dia.		O ₃	Q (Deg)	V	No. Width	
											L	Dia.				No.	Width
9EB325	143274	424	105	47	5	88,9	117	225	117	152	8	13	8	22,5	11	9	83
10EB300	143119	483	99	40	4	108,0	133	250	141	178	8	13	8	22,5	11	10	76
12EB350	143122	848	111	48	5	158,8	184	301	192	229	12	13	8	15,0	11	12	89
14EB400	143126	1360	124	48	5	209,6	235	352	243	279	12	13	8	15,0	11	14	102
16EB475	143129	2120	162	64	6	209,6	245	402	244	289	8	13	10	22,5	21	12	121
19EB475	143131	3050	162	64	6	244,5	279	478	279	365	6	19	10	30,0	21	14	121
21.5EB475	143134	4070	162	64	8	308,0	343	541	343	429	8	19	10	22,5	21	16	121
24EB475	143137	5090	162	64	8	371,5	406	605	406	492	8	19	10	22,5	21	18	121
SI		Nm @ 5,2 bar	Dimensions in millimeters														

Airflex® EB Clutch Application



Forms EB 705 and 706 Coupling Mounting Arrangement Dimensional Data – Sizes 6 to 12

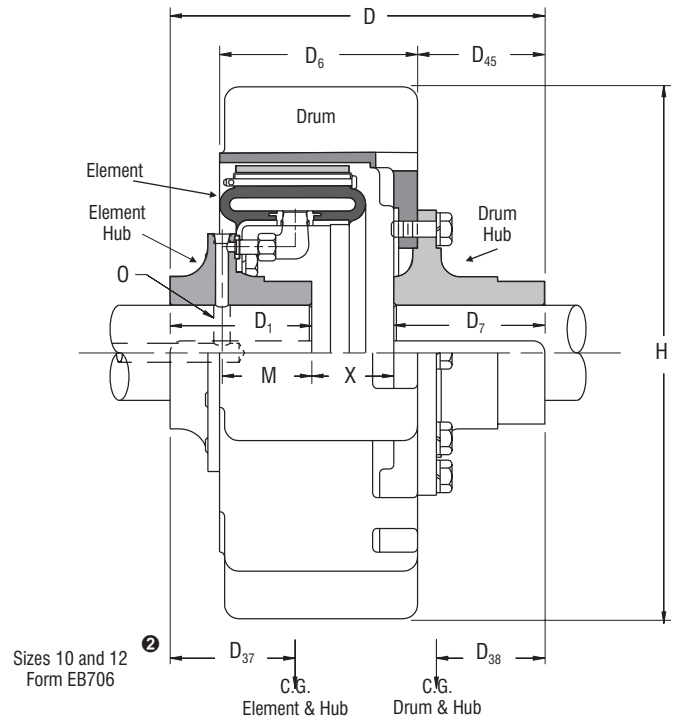
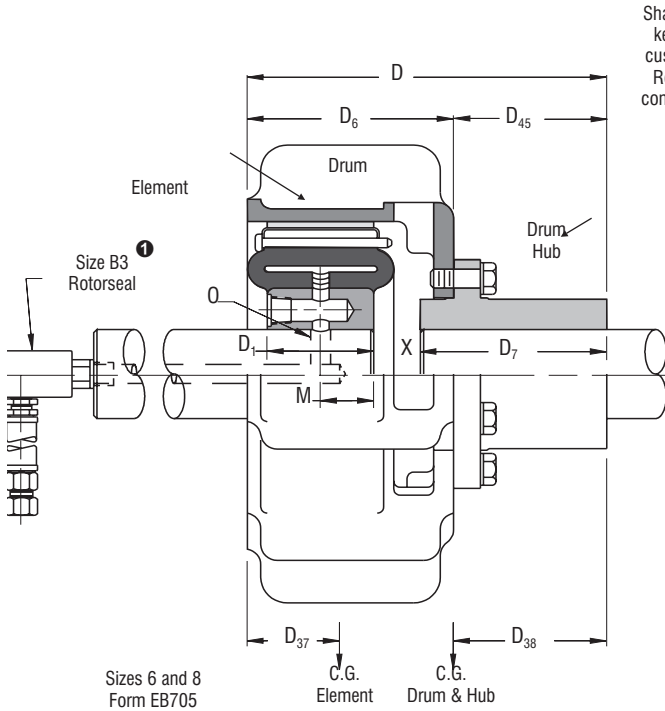

English	Part Number	lb in @ 75 psi	lb	Dimensions in inches												
Size	Part Number	M. Torque Rating	Weight Mass	Min.	Max.	D	D ₁	D ₆	D ₇	D ₃₇	D ₃₈	D ₄₅	H	M	O	X
6EB200	104305	910	25	0.88	1.75	6.75	2.00	3.88	3.50	1.4	3.4	2.87	9.00	1.00	0.38	0.88
8EB250	104306	2220	43	1.25	2.50	7.75	2.50	4.38	4.00	1.6	3.7	3.37	11.00	1.25	0.38	0.88
10EB300	105575	4275	63	1.50	2.50	10.00	3.75	5.25	4.00	2.6	4.3	3.38	14.00	2.38	0.44	2.25
12EB350	104307	7500	104	1.63	3.00	10.50	4.25	6.00	4.25	3.2	4.3	3.13	16.00	2.88	0.44	2.00

SI	Part Number	N m @ 5,2 bar	kg	Dimensions in millimeters												
Size	Part Number	M. Torque Rating	Weight Mass	Min.	Max.	D	D ₁	D ₆	D ₇	D ₃₇	D ₃₈	D ₄₅	H	M	O	X
6EB200	104305	103	11	22	44	171	51	99	89	36	86	73	229	25	10	22
8EB250	104306	250	19	32	64	197	64	111	102	41	94	86	279	32	10	22
10EB300	105575	480	29	38	64	254	95	133	102	66	109	86	356	60	11	57
12EB350	104307	850	47	41	76	267	108	152	108	81	109	80	406	73	11	51

- Notes:**
- ① Refer to Rotorseal Section for mounting and dimension information.
 - ② For larger sizes, it is recommended that the E product line be used. See Form E604.
 - ③ Refers to basic part number only and does not include the rotorseal and hose.
 - ④ Dynamic torque shown, static torque approximately 25% greater. Torque in each application is dependent upon air pressure and speed.
 - ⑤ Based upon minimum bores. Rotorseal and hose not included.

Airflex® EB Clutch Application



Forms EB 707 and 708 Bearing Arrangement – Dimensional Data – Sizes 6 to 12

Shaft and keys by customer.
Refer to component catalog pages for component details.

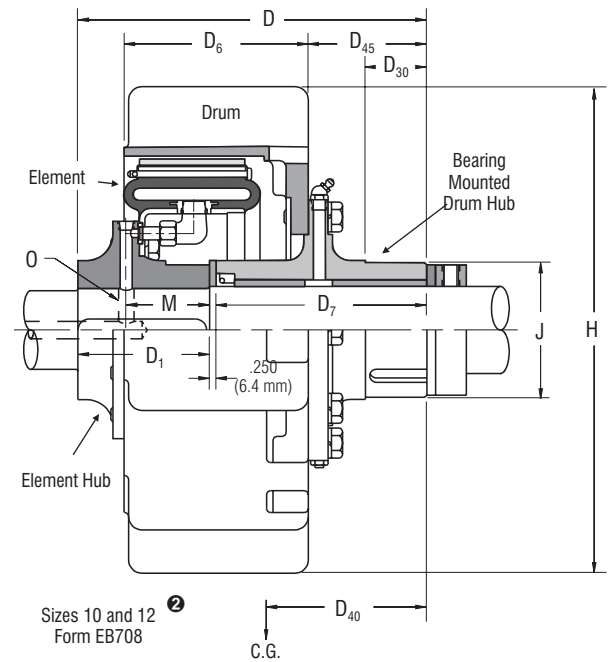
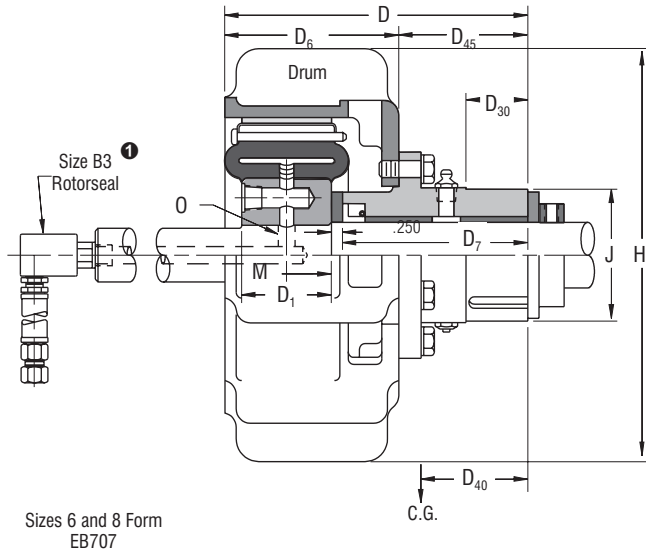

English		lbin @ 75 psi	lb	Dimensions in inches												
6EB200	106914	910	25	0.88	1.75	6.75	2.00	3.88	4.13	1.38	3.8	9.00	2.875	1.00	0.38	
8EB250	106915	2200	49	1.25	2.50	7.75	2.50	4.38	4.63	1.88	4.3	11.00	3.875	1.25	0.38	
10EB300	106935	4275	69	1.50	2.50	10.00	3.75	5.25	6.00	1.75	5.4	14.00	3.875	2.38	0.44	
12EB350	106936	7500	110	1.63	3.00	10.50	4.25	6.00	6.00	1.63	5.7	16.00	4.875	4.25	0.44	
Size	Part Number ^③	M, Torque Rating ^④	Weight ^⑤ Mass	Bore Range		D	D ₁	D ₆	D ₇	D ₃₀	D ₄₀	H	J _{MAX}	M	O	
				Min.	Max.											
				Min.	Max.											
6EB200	106914	103	11	22	44	171	51	99	105	35	97	229	73,0	25	10	
8EB250	106915	249	22	32	64	197	64	111	118	48	109	279	98,4	32	10	
10EB300	106935	483	31	38	64	254	95	133	152	44	137	356	98,4	60	11	
12EB350	106936	848	50	41	76	267	108	152	152	41	145	406	123,8	108	11	
SI		Nm @ 5,2 bar	kg	Dimensions in millimeters												

Notes:

- ① Refer to Rotorseal Section for mounting and dimension information.
- ② For larger sizes, it is recommended that the E product line be used. See Form E604.
- ③ Refers to basic part number only and does not include the rotor seal and hose.
- ④ Dynamic torque shown, static torque approximately 25% greater. Torque in each application is dependent upon air pressure and speed.
- ⑤ Based upon minimum bores. Rotorseal and hose not included.

Airflex® EB Brake Application



Forms EB 709 and 710 Dimensional Data Sizes 6 to 12

Shaft, key, and reaction members by customer.
Refer to component catalog pages
for component details.

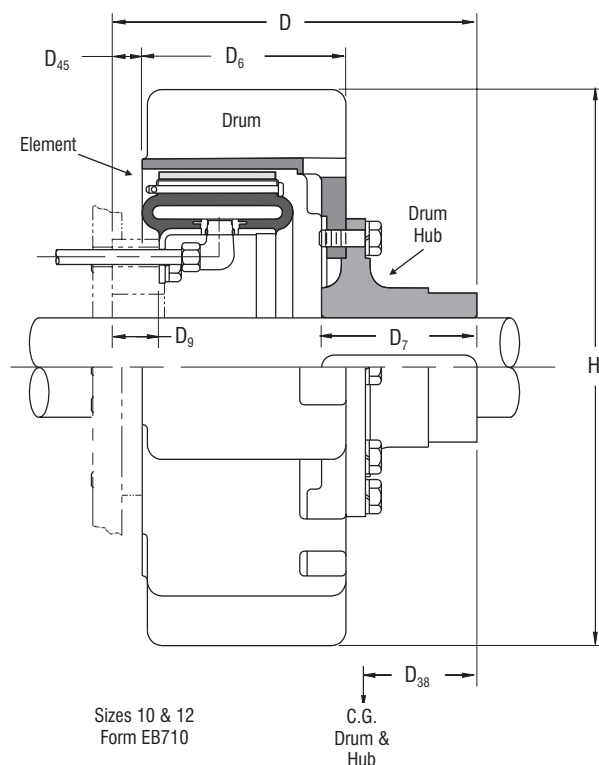
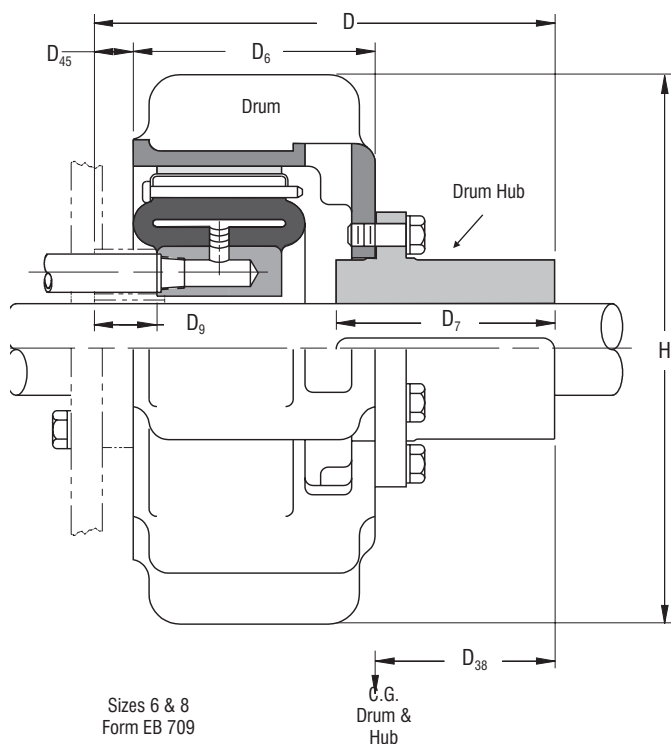

English		lb in @ 75 psi	lb	Dimensions in inches								
6EB200	104308	910	25	0.88	1.75	7.38	3.88	3.50	1.00	3.25	0.63	9.00
8EB250	104309	2220	48	1.25	2.50	8.38	4.38	4.00	1.00	3.50	0.63	11.00
10EB300	104310	4275	51	1.50	2.50	9.38	5.25	4.00	1.13	4.00	0.75	14.00
12EB350	104311	7500	80	1.63	3.00	9.88	6.00	4.25	1.06	4.00	0.75	16.00
Size	Part Number	M, Torque Rating	Weight Mass	Bore Range		D	D ₆	D ₇	D ₉	D ₃₈	D ₄₅	H
				Min.	Max.							
				Min.	Max.							
6EB200	104308	103	11	22	44	187	99	89	25	83	16	229
8EB250	104309	251	22	32	64	213	111	102	25	89	16	279
10EB300	104310	483	23	38	64	238	133	102	29	102	19	356
12EB350	104311	848	36	41	76	251	152	108	27	102	19	406
SI		Nm @ 5,2 bar	kg	Dimensions in millimeters								

Notes:

- ① Refers to basic part number only.
- ② Dynamic torque shown, static torque approximately 25% greater. Torque in each application is dependent upon air pressure and speed.
- ③ Based upon minimum bores.

Airflex® ER Elements



Form ER 703

Dimensional and Technical Data Sizes 3 to 8

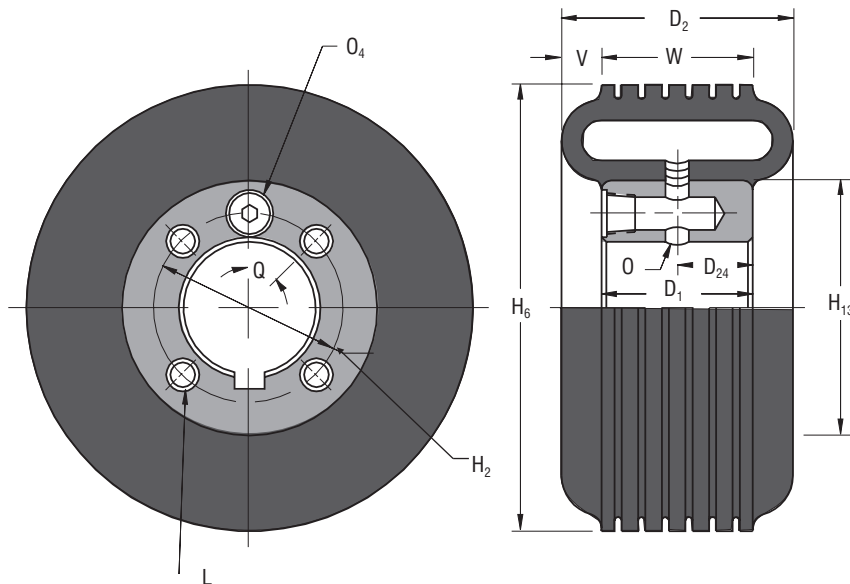

English		lb in @ 75 psi	Dimensions in inches															
3ER125	512175	400	-	0.98	1.50	1.75	0.75	NA	2.94 ^⑥	1.75	NA	NA	NA	0.38	NA	NA	0.25	1.25
6ER200	145158	1540	0.88	1.75	2.00	3.06	1.00	2.50	5.91	3.38	4	3/8-16	0.62	0.31	1/4-18	45.0	0.53	2.00
8ER250	145159	3550	1.25	3.50	2.50	3.56	1.25	4.38	7.91	5.38	4	3/8-16	0.88	0.31	1/4-18	22.5	0.53	2.50
Size	Part Number ^①	M _s Torque Rating ^②	Bore Range		D ₁	D ₂	D ₂₄	H ₂	H ₆	H ₁₃	L ^③			O	O ₄	Q (Deg)	V	W
			Min.	Max.							No.	Size	Depth					
			Min.	Max.							No.	Size	Depth					
3ER125	512175	45.2	-	25	38	44	19	NA	75 ^⑥	44	NA	NA	NA	10	NA	NA	6	32
6ER200	145158	174	22	44	51	78	25	64	150	86	4	3/8-16	16	8	1/4-18	45.0	13	51
8ER250	145159	401	32	89	64	90	32	111	201	137	4	3/8-16	22	8	1/4-18	22.5	13	64

SI		Nm @ 5,2 bar	Dimensions in millimeters													
English		lb in @ 75 psi	rpm	lb ft ²	lb	in ³	in									
3ER125	512175	400	1800	0.01	1.1	4	3.09									
6ER200	145158	1540	1800	0.1	7	20	6.09									
8ER250	145159	3550	1800	0.5	18	35	8.09									
Size	Part Number ^①	M _s ^② Torque Rating	Maximum Speed	Wk ² J	⑥	Weight Mass	Maximum ^⑤ Air Cavity	Maximum Drum Diameter								
									Maximum							
3ER125	512175	45.2	1800	0,001	0,5	0,07	78									
6ER200	145158	174	1800	0,004	3,2	0,33	155									
8ER250	145159	401	1800	0,02	8,2	0,57	205									
SI		Nm @ 5,2 bar	rpm	kg m ²	kg	dm ³	mm									

Notes:

- ①** Refers to basic part number only. When ordering, it must be specified which air entry hole, O or O₄ is to be used.
- ②** Static torque.
- ③** American National Standard for Unified Screw Threads.
- ④** American National Pipe Thread
- ⑤** Drum contact with worn shoes.
- ⑥** Based upon minimum bores.
- ⑦** This element has six equally spaced rubber pads on the tube diameter instead of circumferential grooves.

Airflex® ER Elements



Form ER 704

Technical Data

Sizes 10 to 24

English		lb in @ 75 psi	rpm	lb ft ²	lb	in ³	in
10ER300	145161	6600	1800	0.8	8	75	10.09
12ER350	145164	12300	1800	2	13	80	12.09
14ER400	145168	22600	1500	4	17	105	14.09
16ER475	145171	32600	1300	7	31	135	16.13
19ER475	145174	47600	1100	15	39	330	19.13
21.5ER475	145177	63000	1000	27	52	335	21.63
24ER475	145180	83500	900	41	61	375	24.13
Size	Part ^① Number	M _s ^② Torque Rating	Maximum Speed	Wk ²	Weight	Air ^③ Tube Cavity	Maximum Drum Diameter
				J	Mass		
10ER300	145161	746	1800	0,03	3,6	1,23	256
12ER350	145164	1390	1800	0,08	5,9	1,31	307
14ER400	145168	2550	1500	0,17	7,7	1,72	358
16ER475	145171	3680	1300	0,29	14	2,21	410
19ER475	145174	5380	1100	0,63	18	5,41	486
21.5ER475	145177	7120	1000	1,13	24	5,49	549
24ER475	145180	9440	900	1,72	28	6,15	613
SI		Nm @ 5,2 bar	rpm	kg m ²	kg	dm ³	mm

Notes:

- ① Refers to basic part number only.
- ② Static torque.
- ③ Drum contact with worn shoes.

Airflex® ER Elements



Form ER 704

Dimensional Data

Sizes 10 to 24

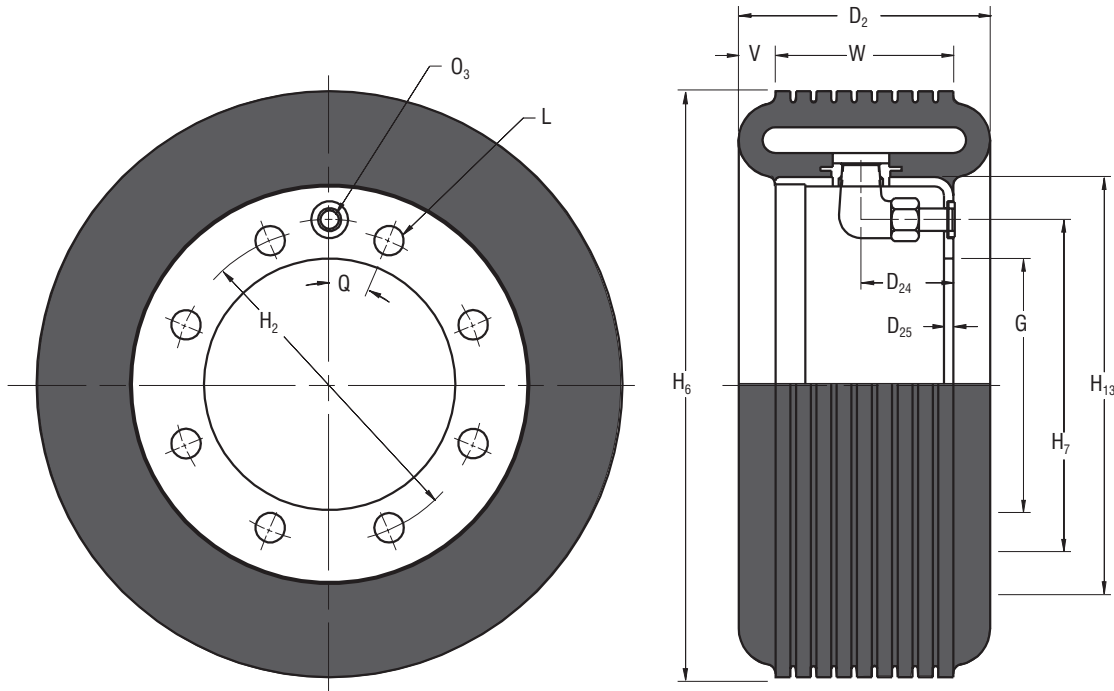

English		Ibin @ 75 psi	Dimensions in inches													
10ER300	145161	6600	4.25	1.56	0.16	4.250	5.25	9.90	5.56	7.00	8	0.50	0.31	22.5	0.63	3.00
12ER350	145164	12300	4.75	1.88	0.19	6.250	7.25	11.90	7.56	9.00	12	0.50	0.31	15.0	0.63	3.50
14ER400	145168	22600	5.25	1.88	0.19	8.250	9.25	13.91	9.56	11.00	12	0.50	0.31	15.0	0.63	4.00
16ER475	145171	32600	6.63	2.50	0.25	8.250	9.63	15.81	9.62	11.38	8	0.50	0.38	22.5	0.94	4.75
19ER475	145174	47600	6.63	2.50	0.25	9.625	11.00	18.81	11.00	14.38	6	0.75	0.38	30.0	0.94	4.75
21.5ER475	145177	63000	6.63	2.50	0.31	12.125	13.50	21.31	13.50	16.88	8	0.75	0.38	22.5	0.94	4.75
24ER475	145180	83500	6.63	2.50	0.31	14.625	16.00	23.81	16.00	19.38	8	0.75	0.38	22.5	0.94	4.75
Size	① Part Number	② M, Torque Rating	D_2	D_{24}	D_{25}	G	H_2	H_6	H_7	H_{13}	No. Dia.		O_3	Q	V	W
											L					
											No.	Dia.				
10ER300	145161	746	108	40	4	108,0	133	251	141	178	8	13	8	23	16	76
12ER350	145164	1390	121	48	5	158,8	184	302	192	229	12	13	8	15	16	89
14ER400	145168	2550	133	48	5	209,6	235	353	243	279	12	13	8	15	16	102
16ER475	145171	3680	168	64	6	209,6	245	402	244	289	8	13	10	23	24	121
19ER475	145174	5380	168	64	6	244,5	279	478	279	365	6	19	10	30	24	121
21.5ER475	145177	7120	168	64	8	308,0	343	541	343	429	8	19	10	23	24	121
24ER475	145180	9440	168	64	8	371,5	406	605	406	492	8	19	10	23	24	121
SI		Nm @ 5,2 bar	Dimensions in millimeters													

Airflex® ER Coupling Application



Form ER 716

Dimensional Data

Sizes 6 and 8

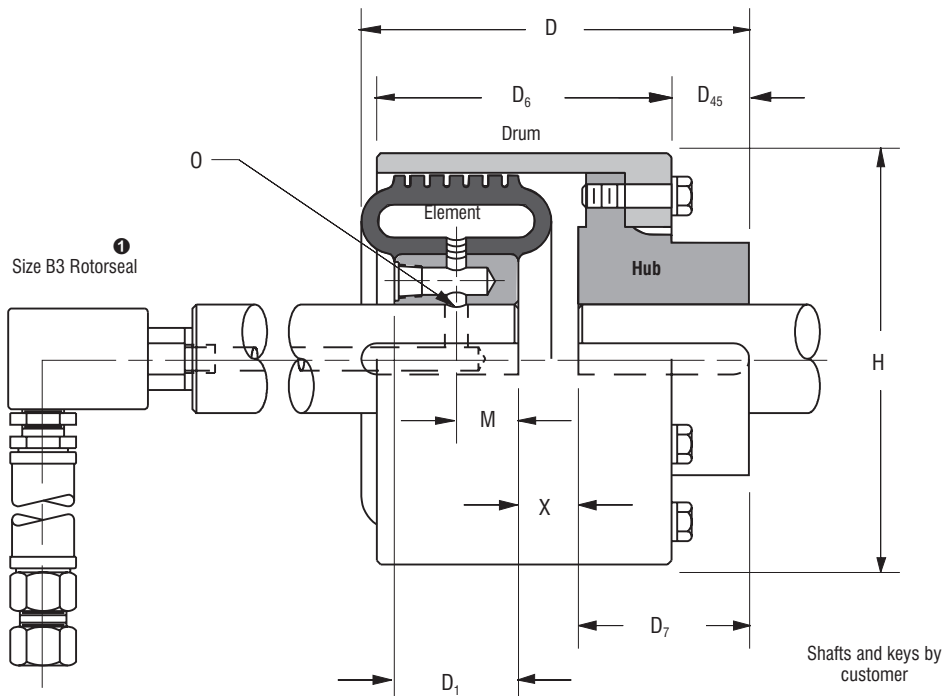

English	lb in @ 75 psi	lb	Dimensions in inches								
6ER200	1540	30	6.00	2.00	4.50	2.75	1.25	6.63	1.00	0.28	0.75
8ER250	3550	50	7.00	2.50	5.00	3.25	1.75	8.63	1.25	0.28	0.75
Size	M, ② Torque Rating	Weight ③ Mass ③	D	D ₁	D ₆	D ₇	D ₄₅	H	M	O	X
6ER200	174	14	152	51	114	70	32	168	25	7	19
8ER250	401	23	178	64	127	83	44	219	32	7	19
SI	Nm @ 5,2 bar	kg	Dimensions in millimeters								

Notes:

- ① Refer to Rotorseal for mounting and dimension information.
- ② Static Torque.
- ③ Based on minimum bores.

Airflex® ER Coupling Application



Form ER 717

Dimensional Data

Sizes 10 to 24

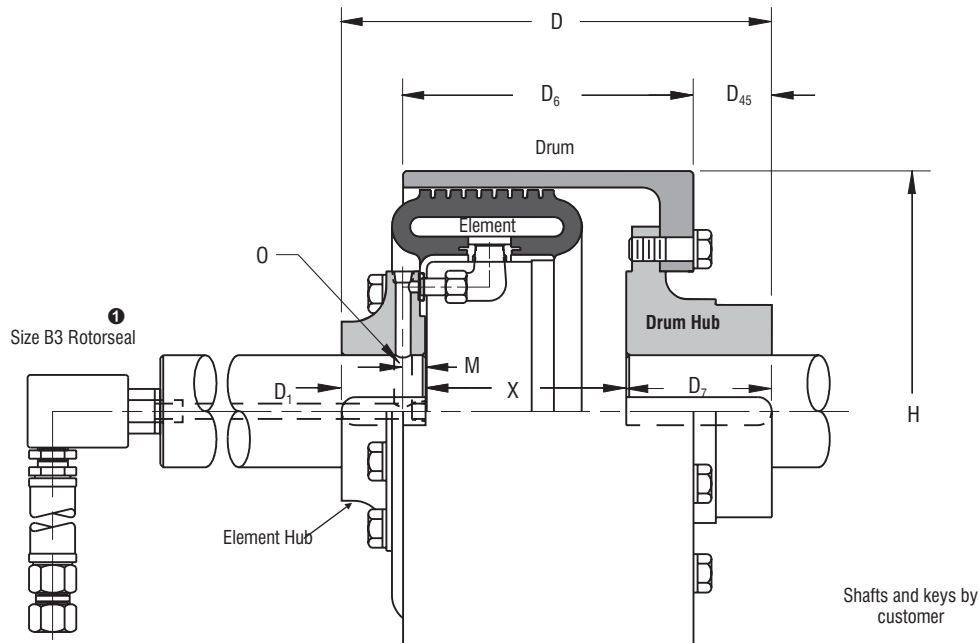

English	lb in @ 75 psi	lb	Dimensions in inches										
10ER300	6600	70	1.50	2.50	10.75	2.88	6.50	3.25	1.75	10.75	1.38	0.34	4.63
12ER350	12300	120	1.50	3.00	13.50	3.38	7.00	5.00	3.50	12.75	1.38	0.34	5.13
14ER400	22600	185	1.75	4.50	16.63	5.13	7.50	5.75	4.75	14.75	1.38	0.44	5.75
16ER475	32600	220	2.25	4.50	18.00	5.13	9.00	5.75	4.75	16.75	1.38	0.34	7.13
19ER475	47600	275	2.25	4.50	18.00	5.13	9.00	5.75	4.75	19.75	1.38	0.34	7.13
21.5ER475	63000	360	2.25	4.50	19.50	5.88	9.00	6.50	5.50	22.25	1.44	0.34	7.13
24ER475	83500	390	2.75	4.75	19.50	5.88	9.00	6.50	5.50	24.75	1.44	0.34	7.13
Size	M _s Torque Rating ²	Weight Mass ³	Min.	Max.	D	D ₁	D ₆	D ₇	D ₄₅	H	M	O	X
			Bore Range										
			Min.	Max.									
10ER300	746	32	38	64	273	73	165	83	44	273	35	9	117
12ER350	1390	54	38	76	343	86	178	127	89	324	35	9	130
14ER400	2550	84	44	114	422	130	191	146	121	375	35	11	146
16ER475	3680	100	57	114	457	130	229	146	121	425	35	9	181
19ER475	5380	125	57	114	457	130	229	146	121	502	35	9	181
21.5ER475	7120	163	57	114	495	149	229	165	140	565	37	9	181
24ER475	9440	177	70	121	495	149	229	165	140	629	37	9	181
SI	Nm @ 5,2 bar	kg	Dimensions in millimeters										

Notes:

- ① Refer to Rotorseal Section for mounting and dimension information.
- ② Static torque.
- ③ Based upon minimum bores.

Airflex® EB and ER Mounting Components



Form EB 711

Element Hub – Dimensional and Technical Data – Sizes 10 to 24

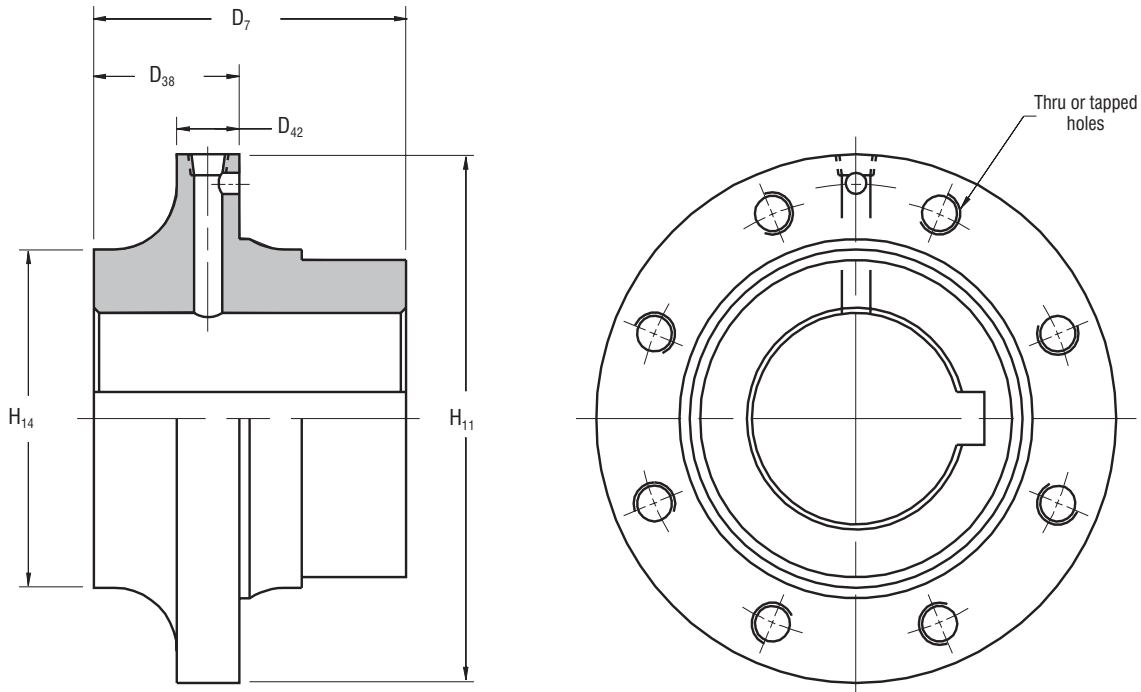

English	Thru Holes	Tapped Holes	lb	lb ft ²	Dimensions in inches				
10EB&ER300	402469	402470	12	0.5	3.75	1.75	0.75	6.25	4.00
12EB&ER350	402471	402472	24	1	4.25	1.75	0.75	8.25	5.00
14EB&ER400	402473	402474	55	3	6.00	1.75	0.75	10.38	7.00
16EB&ER475	402475	402476	56	4	6.00	1.75	0.75	10.63	7.00
19EB&ER475	402477	402478	64	5	6.00	1.75	0.75	12.50	7.00
21.5EB&ER475	402479	402480	85	10	6.75	1.88	0.88	15.00	7.00
24EB&ER475	402481	402482	99	16	6.75	1.88	0.88	17.50	7.50
Size	Part Number		Weight Mass	Wk ² J	D ₇	D ₂₉	D ₄₂	H ₁₁	H ₁₄
10EB&ER300	402469	402470	5,4	0,02	95	44	19	159	102
12EB&ER350	402471	402472	11	0,04	108	44	19	210	127
14EB&ER400	402473	402474	25	0,13	152	44	19	264	178
16EB&ER475	402475	402476	25	0,17	152	44	19	270	178
19EB&ER475	402477	402478	29	0,21	152	44	19	318	178
21.5EB&ER475	402479	402480	39	0,42	171	48	22	381	178
24EB&ER475	402481	402482	45	0,67	171	48	22	445	191
SI	Thru Holes	Tapped Holes	kg	kg m ²	Dimensions in millimeters				

Notes:

① Based upon minimum bores.

Airflex® EB and ER Mounting Components



Form EB 712

Hub for Non-Ventilated Internal Flange Drum
Dimensional and Technical Data – Sizes 6 to 24

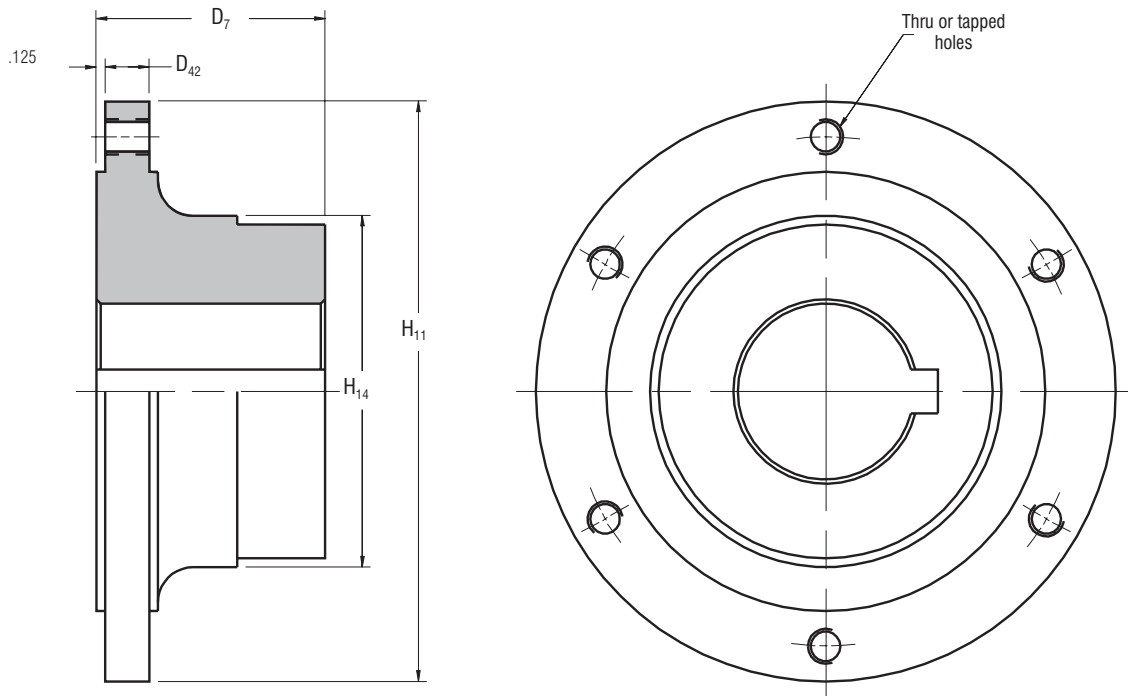

English	Thru Holes	Tapped Holes	lb	lb ft ²	Dimensions in inches			
6EB&ER200	406900	406901	12	0.5	2.75	0.63	6.00	4.00
8EB&ER250	N/A	416087	18	0.9	3.25	0.63	8.25	5.00
10EB&ER300	406902	406903	18	0.9	3.25	0.63	8.25	5.00
12EB&ER350	406904	406905	46	3.5	5.00	0.63	10.25	7.00
14EB&ER400	406906	406907	68	6.5	5.75	0.75	13.50	7.00
16EB&ER475	406908	406909	74	6.5	5.75	0.75	15.00	7.50
19EB&ER475	406910	406911	93	8.5	5.75	0.75	17.50	7.50
21.5EB&ER475	406912	406913	131	29	6.50	0.75	20.00	8.50
24EB&ER475	406916	406917	132	30	6.50	0.75	21.50	8.50
Size	Part Number		Weight Mass	Wk ² J	D ₇	D ₄₂	H ₁₁	H ₁₄
6EB&ER200	406900	406901	5,4	0,02	70	16	152	102
8EB&ER250	N/A	416087	8,2	0,04	83	16	210	127
10EB&ER300	406902	406903	8,2	0,04	83	16	210	127
12EB&ER350	406904	406905	21	0,15	127	16	260	178
14EB&ER400	406906	406907	31	0,27	146	19	343	178
16EB&ER475	406908	406909	34	0,27	146	19	381	191
19EB&ER475	406910	406911	42	0,36	146	19	445	191
21.5EB&ER475	406912	406913	59	1,22	165	19	508	216
24EB&ER475	406916	406917	60	1,26	165	19	546	216
SI	Thru Holes	Tapped Holes	kg	kg m ²	Dimensions in millimeters			

Notes:

① Based upon minimum bores.

Airflex® EB Mounting Components



Form EB 713

Hub for Ventilated Internal Flange Drum
Dimensional and Technical Data – Sizes 6 to 12

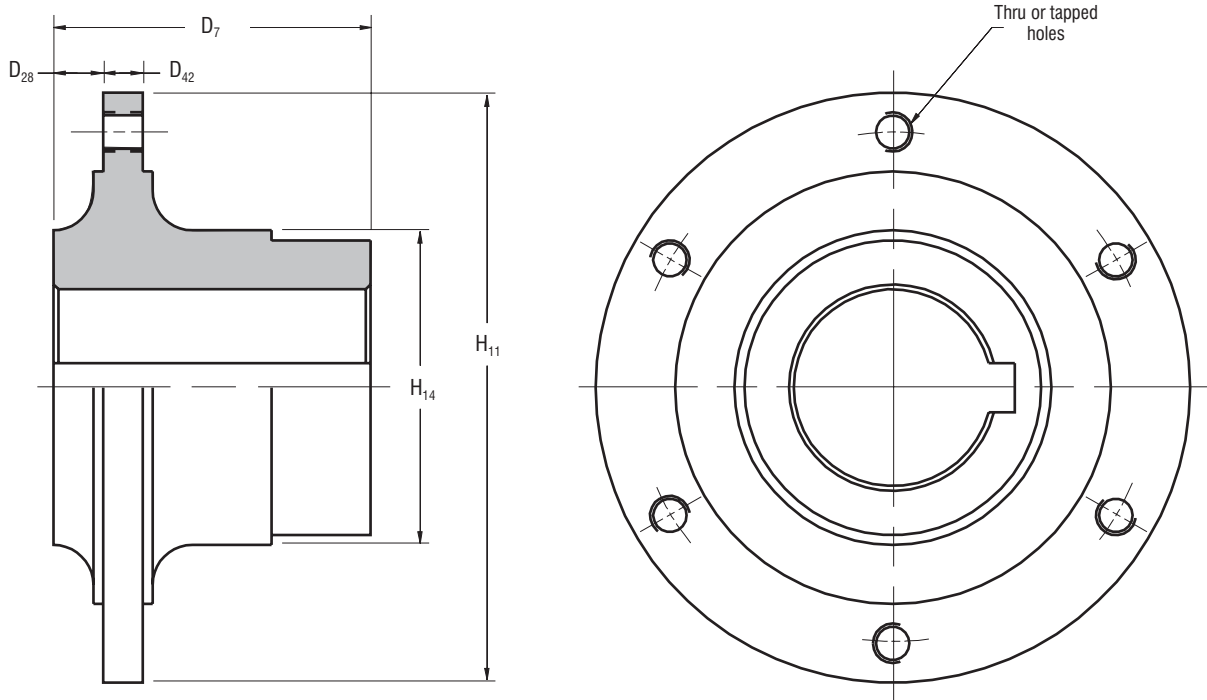

English	Thru Holes	Tapped Holes	lb	lbft ²	Dimensions in inches				
6EB200	402540	402541	7	0.05	3.50	0.63	0.50	4.50	2.94
8EB250	402542	402543	15	0.2	4.00	0.63	0.50	6.25	4.00
10EB300	402544	402545	16	0.3	4.00	0.63	0.50	7.50	4.00
12EB350	402264	402433	25	0.5	4.25	1.13	0.63	8.25	5.00
Size	Part Number		Weight Mass	Wk ² J	D ₇	D ₂₈	D ₄₂	H ₁₁	H ₁₄
6EB200	402540	402541	3,2	0,0021	89	16	13	114	75
8EB250	402542	402543	6,8	0,01	102	16	13	159	102
10EB300	402544	402545	7,2	0,01	102	16	13	191	102
12EB350	402264	402433	11	0,02	108	29	16	210	127
SI	Thru Holes	Tapped Holes	kg	kg·m ²	Dimensions in millimeters				

Notes:

① Based upon minimum bores.

Airflex® EB Mounting Components



Form EB 714

Ventilated Internal Flange Drum – Dimensional and Technical Data
Sizes 6 to 12

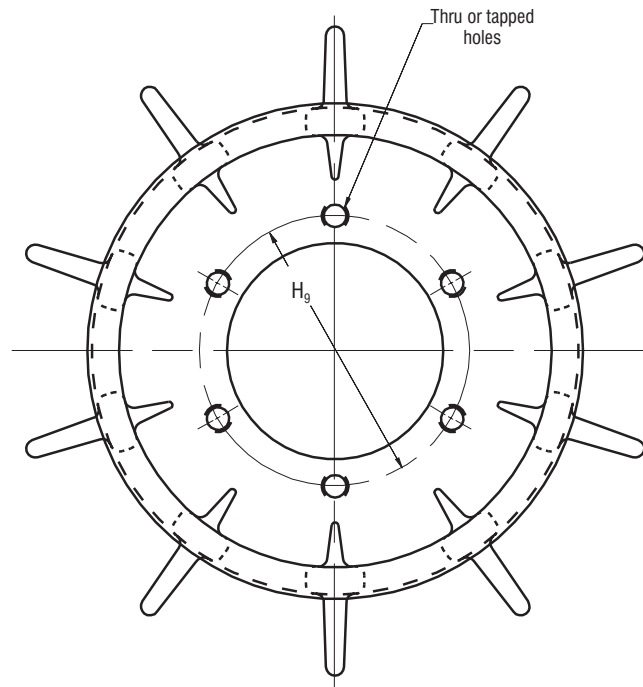
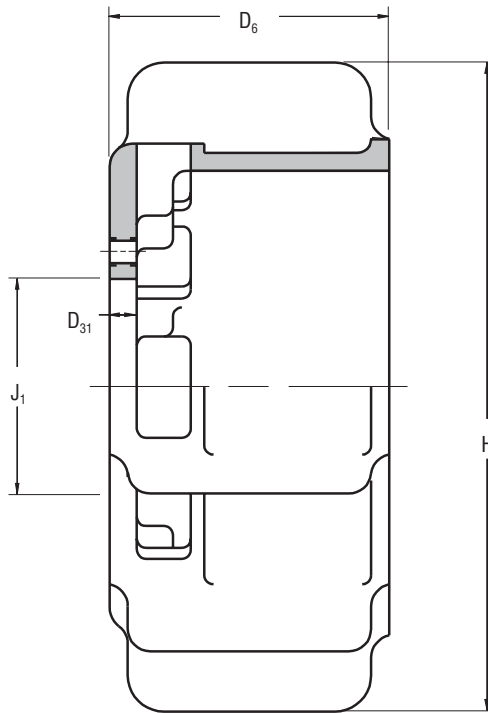

English	Thru Holes	Tapped Holes	lb	lb-ft ²	Dimensions in inches							
6EB200	402226	402632	11	1	3.88	0.38	3.000	9	3.75	6	0.41	3/8-16
8EB250	402228	402633	14	2	4.38	0.38	4.750	11	5.50	6	0.41	3/8-16
10EB300	413255	413451	25	5	5.25	0.50	5.500	14	6.50	6	0.53	1/2-13
12EB350	402231	402635	39	10	6.00	0.50	6.250	16	7.25	6	0.53	1/2-13
Size	Part Number		Weight	Wk ²	D ₆	D ₃₁	J ₁	H	H ₉	No.	Thru	Tapped
			Mass	J						L ^②		
6EB200	402226	402632	5,0	0,04	99	10	76,2	229	95	6	10	3/8-16
8EB250	402228	402633	6,3	0,08	111	10	120,7	279	140	6	10	3/8-16
10EB300	413255	413451	11	0,21	133	13	139,7	356	165	6	13	1/2-13
12EB350	402231	402635	18	0,42	152	13	158,8	406	184	6	13	1/2-13
SI	Thru Holes	Tapped Holes	kg	kg·m ²	Dimensions in millimeters							

Notes:

① Tolerance +0.005/-0.000 in (0,13/-0,00 mm)

② American National Standard for Unified Screw Threads.

Airflex® EB and ER Mounting Components



Form EB 715

Non-Ventilated Internal Flange Drum – Dimensional and Technical Data
Sizes 6 to 24

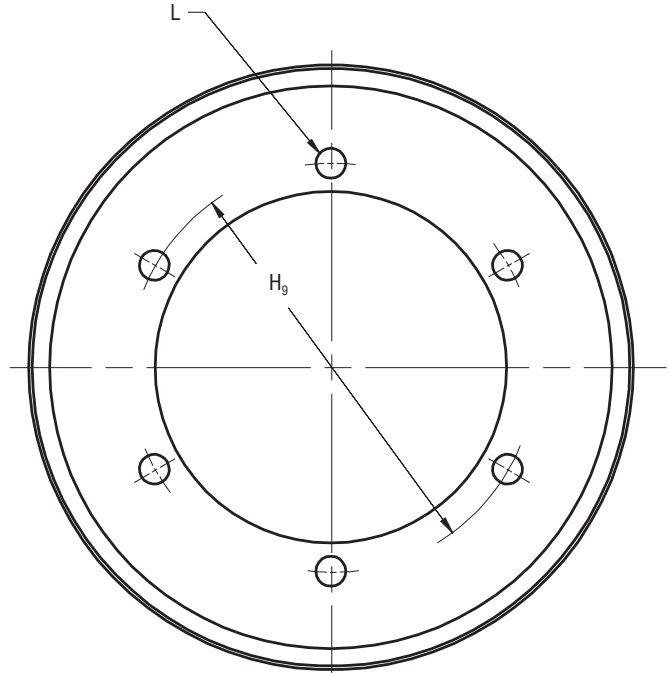
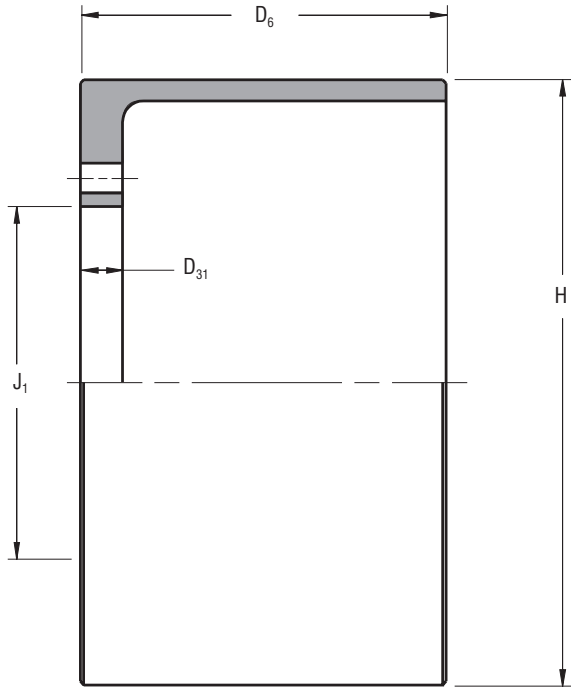

English	Thru Holes	Tapped Holes	lb	lb-ft ²	Dimensions in inches							
6EB&ER200	10236	9365	10	0.8	4.50	0.75	4.250	6.63	5.25	8	0.41	3/8-16
8EB&ER250	10237	9366	15	1.4	5.00	0.75	5.500	8.63	6.50	6	0.53	1/2-13
10EB&ER300	9367	10238	30	5	5.38	0.75	6.250	10.75	7.25	6	0.53	1/2-13
12EB&ER350	9368	10239	38	9	7.00	0.75	8.250	12.75	9.25	6	0.53	1/2-13
14EB&ER400	9369	10240	45	15	7.50	0.75	10.750	14.75	12.00	6	0.78	3/4-10
16EB&ER475	9370	10241	61	26	9.00	0.75	12.130	16.75	13.50	8	0.78	3/4-10
19EB&ER475	10142	10242	77	46	9.00	0.75	14.630	19.75	16.00	8	0.78	3/4-10
21.5EB&ER475	10144	10243	90	69	9.00	0.75	16.750	22.25	18.50	10	0.78	3/4-10
24EB&ER475	10145	10244	98	95	9.00	0.75	19.500	24.75	21.50	14	0.78	3/4-10

Size	Part Number	Weight	Wk ²	D ₆	D ₃₁	① J ₁	H	H ₉	No. Thru Tapped			
									Mass	J	L ②	
6EB&ER200	10236	9365	4,5	0,03	114	19	108,0	168	133	8	10	3/8-16
8EB&ER250	10237	9366	6,8	0,06	127	19	158,8	219	165	6	13	1/2-13
10EB&ER300	9367	10238	14	0,21	137	19	139,7	273	184	6	13	1/2-13
12EB&ER350	9368	10239	17	0,38	178	19	209,6	324	235	6	13	1/2-13
14EB&ER400	9369	10240	20	0,63	191	19	273,1	375	305	6	20	3/4-10
16EB&ER475	9370	10241	28	1,09	229	19	308,1	425	343	8	20	3/4-10
19EB&ER475	10142	10242	35	1,93	229	19	371,6	502	406	8	20	3/4-10
21.5EB&ER475	10144	10243	41	2,90	229	19	425,5	565	470	10	20	3/4-10
24EB&ER475	10145	10244	44	3,99	229	19	495,3	629	546	14	20	3/4-10

SI	Thru Holes	Tapped Holes	kg	kg·m ²	Dimensions in millimeters							
----	------------	--------------	----	-------------------	---------------------------	--	--	--	--	--	--	--

Notes:

- ① Tolerance +0.003/-0.000 in (0,08/-0.00 mm)
- ② American National Standard for Unified Screw Threads