

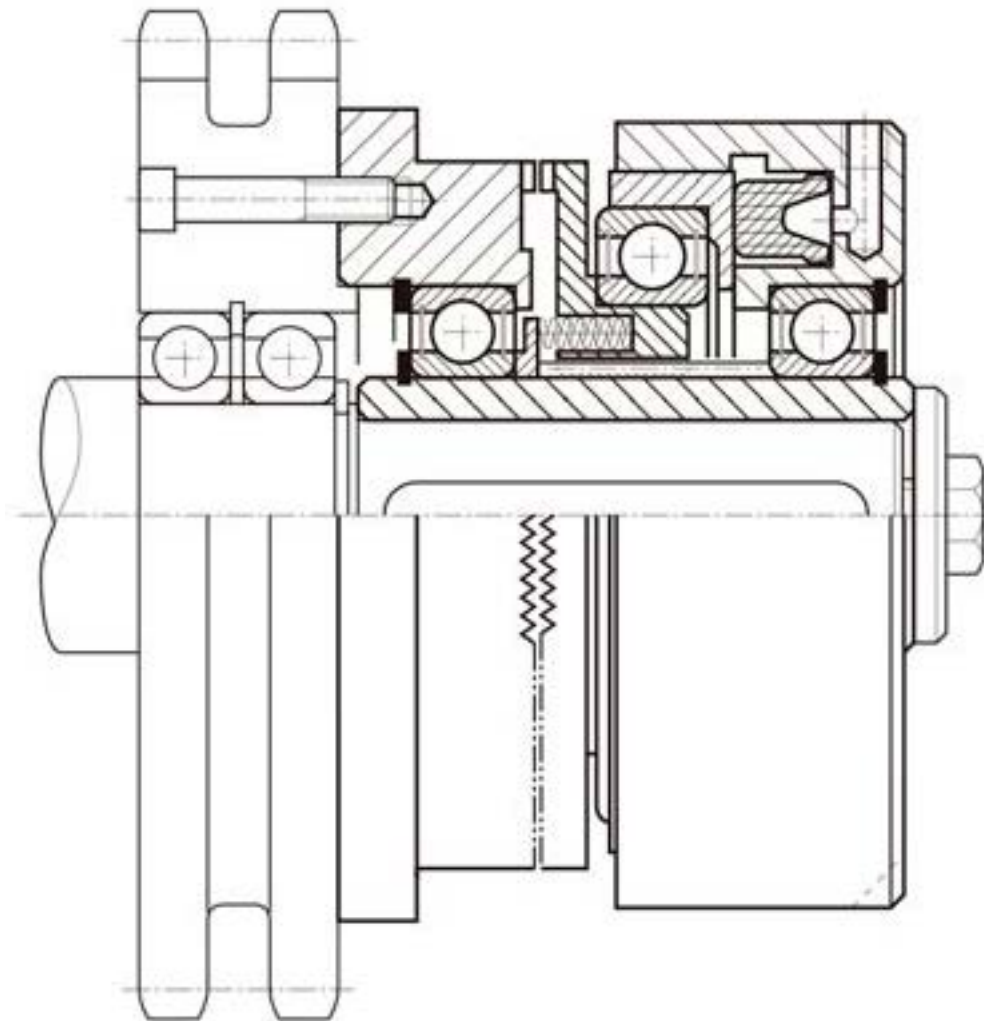

## EMBRAGUE NEUMATICO DE DIENTES DIRECTO

# DPF





# EMBRAGUE NEUMÁTICO DE DIENTES DIRECTO DPF

## EMBRAGUE NEUMÁTICO DE DIENTES DIRECTO

Este dispositivo difiere del acoplamiento de embrague solo en lo que concierne al componente de arrastre.

El movimiento se transmite a través del dentado; el par también es directamente proporcional a la presión de suministro.

Al igual que con los embragues, un conjunto de resortes helicoidales desengancha completamente el dentado de arrastre, liberando así la transmisión durante una pérdida de presión total.

Para garantizar que el acoplamiento y, por lo tanto, la transmisión, funcionen correctamente, la presión de suministro siempre debe permanecer constante; por lo tanto, se debe usar un tanque de acumulación para compensar cualquier cambio de presión.

La válvula de control debe montarse lo más cerca posible del orificio de suministro ubicado en el cilindro y debe estar equipada con un dispositivo de descarga para descargar el pistón y, como consecuencia, que desconecte rápidamente la transmisión.

## MONTAJE Y VERIFICACIÓN DEL ENTREHIERRO

Al montar, siga nuestras instrucciones y ejemplos: El cilindro de trabajo debe estar anclado, pero no bloqueado, por medio de una abrazadera o pasador enganchado en una de las tres manchas fresadas de 120° en el cilindro de trabajo mismo; este soporte debe engancharse al punto fresado más conveniente, en relación con el orificio de suministro de aire, asegurándose de que el cilindro de trabajo tenga algo de juego radial y axial.

Durante la fase de ensamblaje, es muy importante verificar el entrehierro (Q) en 3 puntos a 120° con un medidor de espesor; debe ser como se especifica en las tablas.

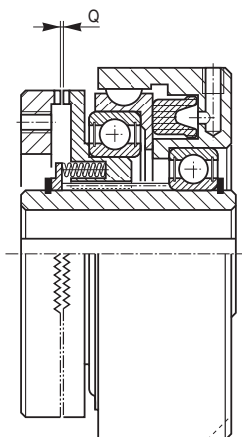

## PNEUMATIC TOOTH-TYPE DIRECT CLUTCH WITH STATIC CYLINDER

These devices differ from clutch couplings only for what concerns the entrainment component. In fact, in couplings motion is transmitted through tothing.

In couplings, the torque is also directly proportional to the supply pressure

Just like with clutches, a set of helical springs completely disengages the entrainment tothing, thus releasing the transmission during a total pressure loss.

To ensure that the coupling, and therefore the transmission, operates correctly, the supply pressure must always remain constant; therefore, an accumulation tank should be used to compensate for any pressure changes.

The control valve must be mounted as close as possible to the supply hole located on the cylinder and it must also be equipped with a blow-off device to discharge the piston and, as a consequence, to quickly disengage the transmission.

## MOUNTING AND AIR GAP ADJUSTMENT

When mounting, please follow our instructions and examples. The working cylinder must be anchored, but not blocked, by means of a bracket or pin engaged on one of the three 120° milled spots on the working cylinder itself; this bracket is to be hooked onto the most convenient milled spot, in relation to the air supply bore, making sure that the working cylinder has some radial and axial play.

During the assembly phase, it is very important to check the air gap (Q) at 3 points at 120° with a thickness gauge; it should be as specified in the relevant tables.

DP		
Grandezza Size	Traferro «Q» Air Gap mm	
00	0,20	0,30
01	0,25	0,35
02	0,30	0,45
03	0,30	0,45
04	0,35	0,50
05	0,35	0,50
06	0,40	0,60
07	0,50	0,70



# EMBRAGUE NEUMATICO DE DIENTES DIRECTO DPF

The teeth can have any one of a number of designs.

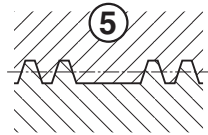
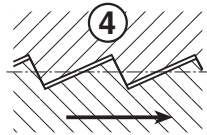
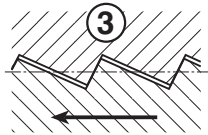
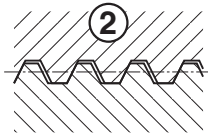
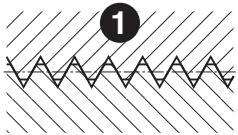

### Triangular teeth without play ① (standard)

This type has no lateral play and only permits engagement when there is no movement or when the velocities are synchronous.

### Trapezoidal teeth with lateral play ②

This type permits engagement when the velocities are synchronous, or at a very low R.P.M.

**On request**, the following features are available: dragging in only one direction (clockwise or counterclockwise), saw-toothed design ③ ④; one or more fixed points of reference, special tooth design ⑤.

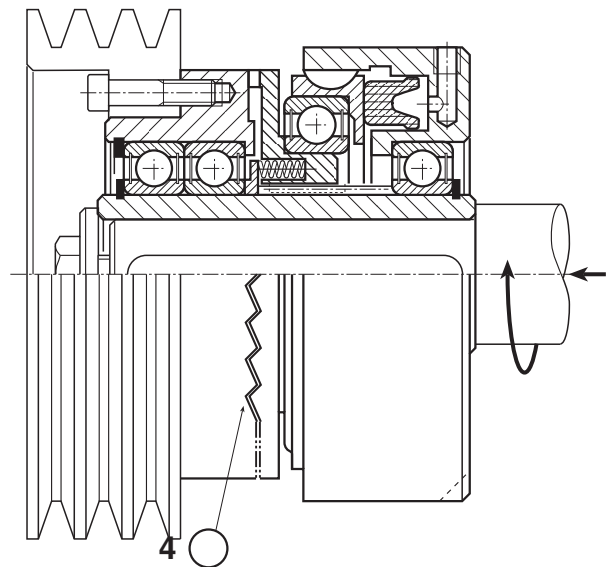
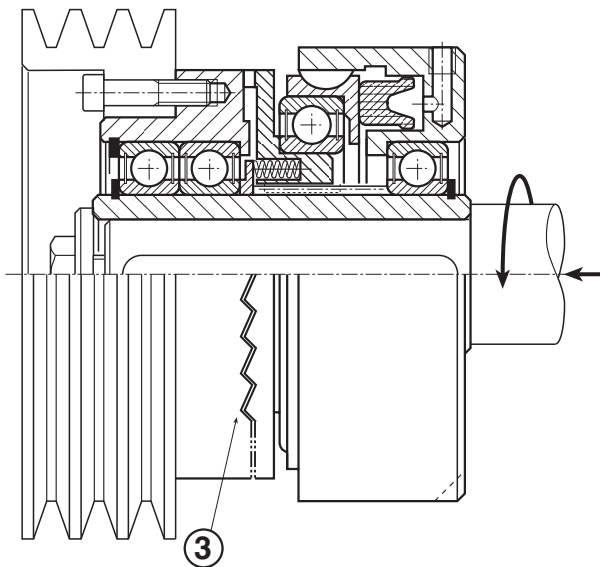



# EMBRAGUE NEUMATICO DE DIENTES DIRECTO

# DPF

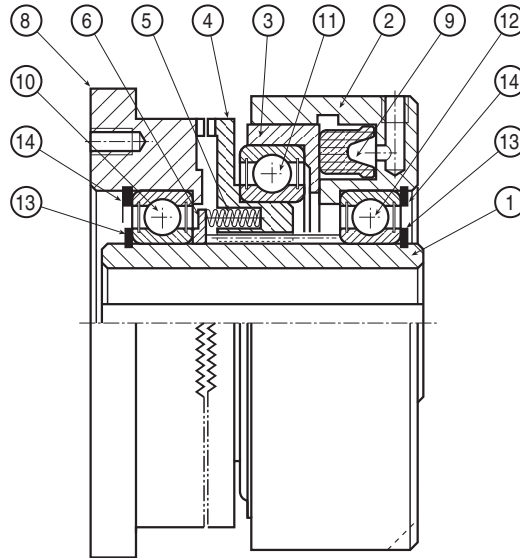

### PARTS LIST

1. CENTRAL HUB
2. CYLINDER
3. PISTON
4. TOOTHED RING
5. SPRING
6. SPRING COMPRESSION RING
7. TOOTHED CUP
8. TRANSMISSION FLANGE
9. SEAL RING
10. FLANGE BEARING
11. PISTON BEARING
12. SLEEVE BEARING
13. OUTER SAFETY RING
14. INNER SAFETY RING

\* There must never be any disalignment between the two parts.

### EXAMPLES OF MOUNTING

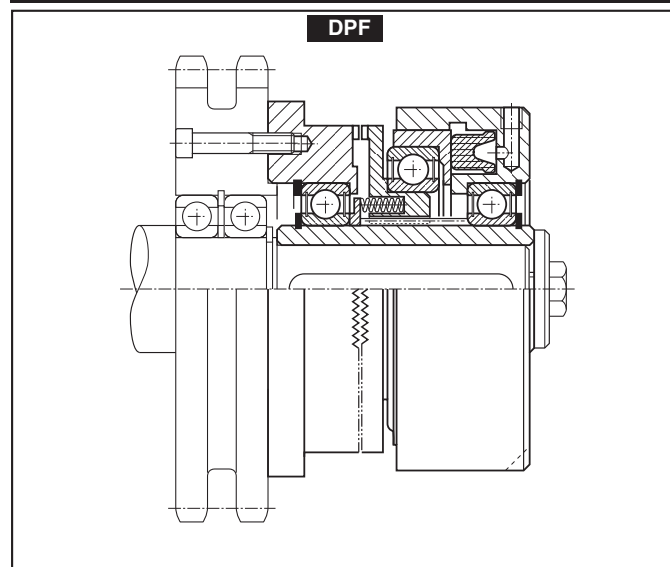



# EMBRAGUE NEUMATICO DE DIENTES DIRECTO DPF

<b>MODEL</b>	DPF □□
<b>CODE</b>	03.24.□□.01

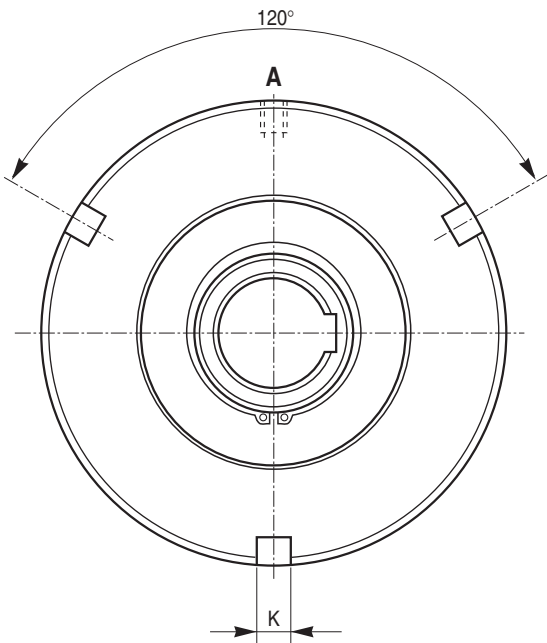

A = Air supply

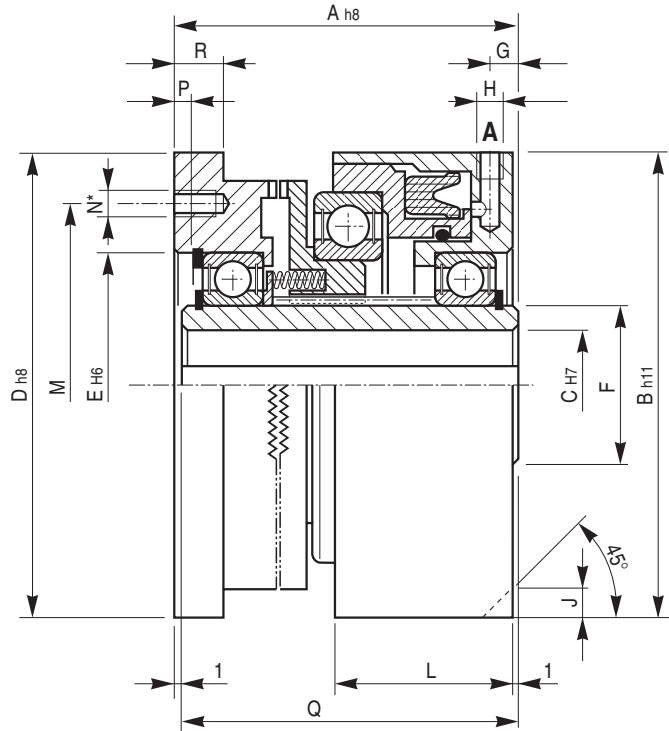

\* **FLANGE DRILLING:**

YOU CAN USE: DPF 00 ÷ 03 = n° 3 a 120° or n° 4 a 90° DPF 04 ÷ 07 = n° 4 a 90° or n° 6 a 60°

□□	Momento Torque Ms (Nm)	Giri/1' R.P.M. max.	Pressione lavoro Working pressure (bar)	Volume cilindro Cilinder volume (cm <sup>3</sup> )	Peso Weight (kg)
00	110	3000	6	6	3,4
01	160	3000	6	8	4,1
02	260	2400	6	12	6
03	350	2400	6	15	7,3
04	550	2000	6	25	10,5
05	750	2000	6	30	12,4
06	1300	1600	6	40	18
07	2100	1400	6	50	26

□□	A	B	C		D	E	F	G	H	J	K	L	M	N* n° x Ø	P	Q	R
			min	max													
00	73	97	14	20	98	55	30	7	1/8"	9	10	38	86	M 6	3	72	11
01	79	115	15	25	111	62	35	7	1/8"	10	10	46	90	M 6	3	78	13
02	82	127	18	34	124	75	45	7	1/8"	10	10	44	110	M 6	3	81	14
03	85	134	18	34	136	75	45	7,5	1/8"	10	10	45	120	M 6	3	84	14
04	93	153	20	46	149	95	60	9	1/4"	12	12	49	130	M 6	3	92	14
05	95	167	25	50	162	100	65	9	1/4"	12	12	55	140	M 8	3	94	17
06	108	193	30	60	194	115	75	9	1/4"	12	12	60	170	M 8	3	107	17
07	123	216	30	68	213	130	85	9	1/4"	14	14	65	190	M10	7	122	21