

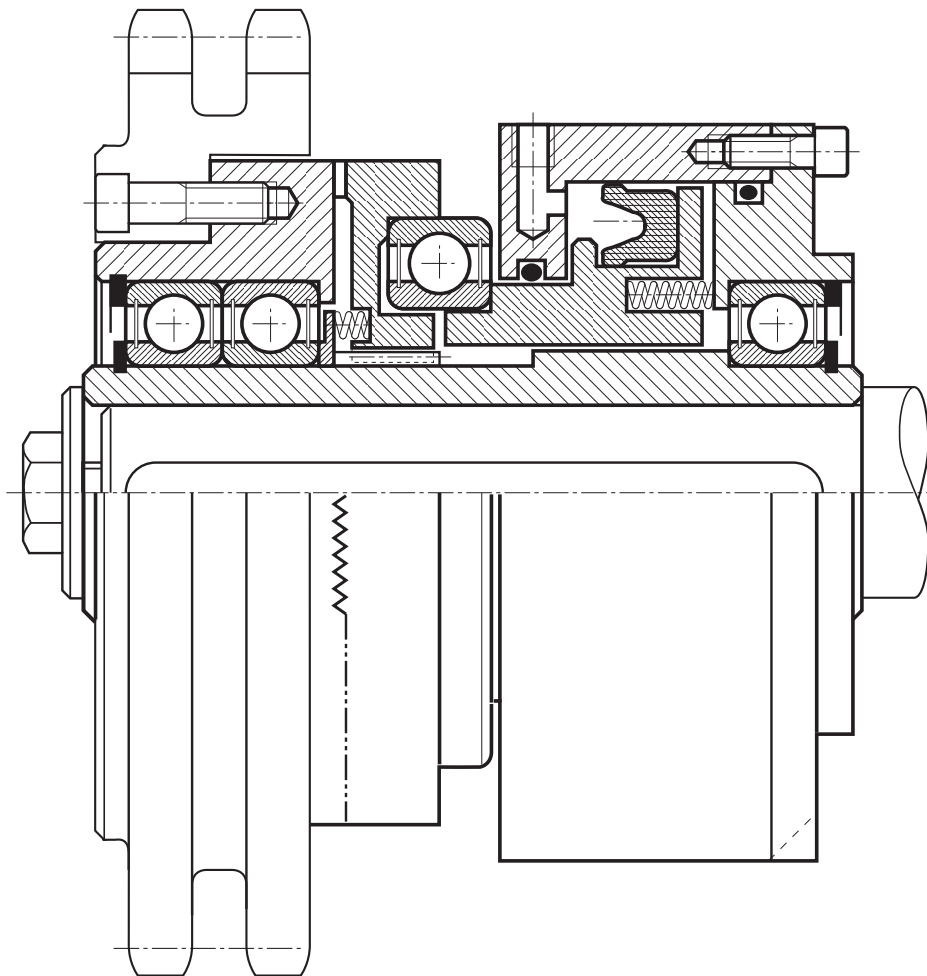

## EMBRAGUE NEUMÁTICO DE DIENTES NEGATIVO

# DPR-N





# EMBRAGUE NEUMATICO DE DIENTES NEGATIVO DPR-N

## EMBRAGUE NEUMÁTICO DE DIENTES DIRECTO

Estos acoplamientos se enganchan por la acción de resortes de empuje, que garantizan el par nominal.

Contrariamente a los liberados por resorte, en condiciones de trabajo estos acoplamientos se enganchan por la acción de resortes de empuje, que garantizan el par nominal.

La desconexión ocurre cuando se suministra aire a presión al cilindro de trabajo a través del orificio de suministro «A» ubicado en el diámetro externo del cilindro de trabajo mismo.

Para obtener una desconexión completa del acoplamiento, debe garantizar la presión de liberación sugerida en este catálogo;

También sugerimos montar la válvula de comando, que debe estar equipada con un dispositivo de descarga, lo más cerca posible del cilindro de trabajo, para enganchar la transmisión de forma rápida y precisa.

## MONTAJE Y AJUSTE DE LA GALGA

Al montar, siga nuestras instrucciones y ejemplos. El cilindro de trabajo debe estar anclado, pero no bloqueado, por medio de una abrazadera o pasador enganchado en una de las tres marcas fresadas de 120° en el cilindro de trabajo mismo; este soporte debe engancharse al punto fresado más conveniente, en relación con el orificio de suministro de aire, asegurándose de que el cilindro de trabajo tenga algo de juego radial y axial. Durante la fase de ensamblaje, es muy importante verificar el entrehierro (Q) en 3 puntos a 120° con un medidor de espesor; debe ser como se especifica en las tablas.

- Montar el acoplamiento de dientes.
- El diente tiene que estar comprometido.
- Desembrague el acoplamiento alimentando con aire al cilindro.
- Compruebe la galga.

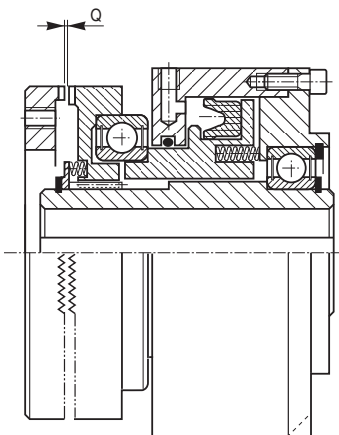

## PNEUMATIC SPRING APPLIED TOOTH-TYPE CLUTCH WITH STATIC CYLINDER

Contrary to the spring released ones, in working conditions these couplings are engaged by the action of thrust springs, which guarantee the nominal torque.

The disengagement occurs when air under pressure is supplied to the working cylinder through the supply bore «A» located on the external diameter of the working cylinder itself.

In order to obtain a complete disengagement of the coupling, you must guarantee the release pressure suggested on this catalogue; we also suggest to mount the command valve, which must be equipped with a blow-off device, as close as possible to the working cylinder, to quickly and precisely engage the transmission.

## MOUNTING AND AIR GAP ADJUSTMENT

When mounting, please follow our instructions and examples. The working cylinder must be anchored, but not blocked, by means of a bracket or pin engaged on one of the three 120° milled spots on the working cylinder itself; this bracket is to be hooked onto the most convenient milled spot, in relation to the air supply bore, making sure that the working cylinder has some radial and axial play.

During the assembly phase, it is very important to check the air gap (Q) at 3 points at 120° with a thickness gauge; it should be as specified in the relevant tables.

- Mount the tooth-type coupling.
- The toothing has to be engaged.
- Disengage the coupling feeding air to the cylinder.
- Check the air gap.

DP-N		
Grandeza Size	Traferro «Q» Air Gap mm	
00	0,20	0,30
01	0,25	0,35
02	0,30	0,45
03	0,30	0,45
04	0,35	0,50
05	0,35	0,50
06	0,40	0,60
07	0,50	0,70



# EMBRAGUE NEUMATICO DE DIENTES NEGATIVO DPR-N

The teeth can have any one of a number of designs.

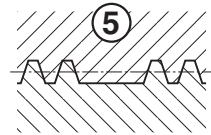
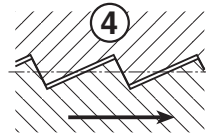
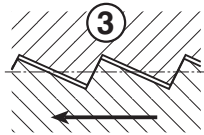
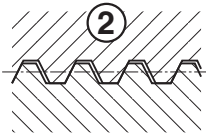
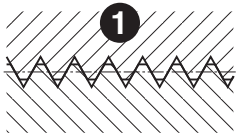

### Triangular teeth without play ① (standard)

This type has no lateral play and only permits engagement when there is no movement or when the velocities are synchronous.

### Trapezoidal teeth with lateral play ②

This type permits engagement when the velocities are synchronous, or at a very low R.P.M.

**On request**, the following features are available: dragging in only one direction (clockwise or counterclockwise), saw-toothed design ③ ④; one or more fixed points of reference, special tooth design ⑤.

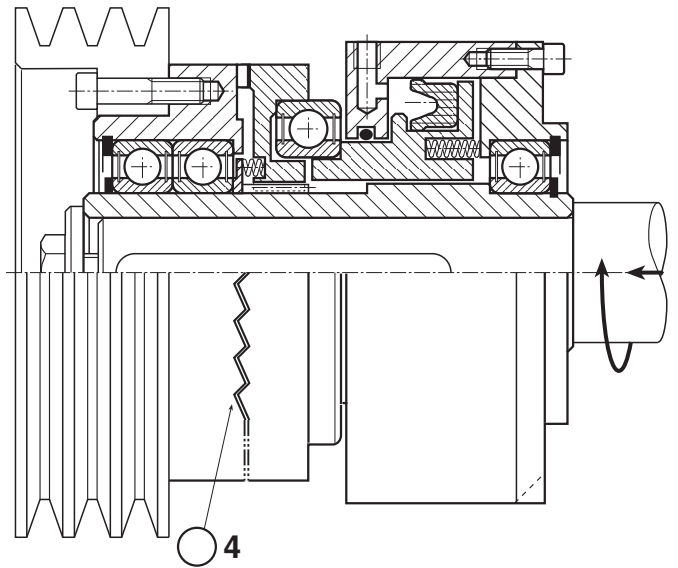
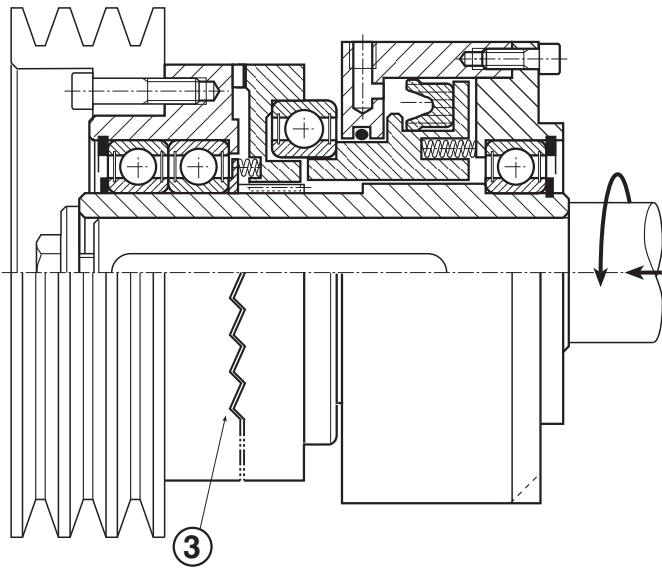



# EMBRAGUE NEUMATICO DE DIENTES NEGATIVO DPR-N

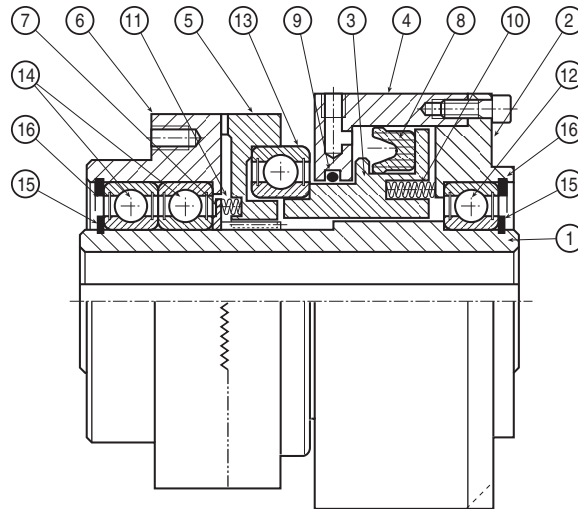

- PARTS LIST**
- 1. CENTRAL HUB
  - 2. COVER FLANGE
  - 3. PISTON
  - 4. CYLINDER
  - 5. TOOTHED RING
  - 6. TRANSMISSION HUB
  - 7. SPRING COMPRESSION RING
  - 8. SEAL RING
  - 9. O-RING
  - 10. SPRING
  - 11. RELEASE SPRING
  - 12. HUB BEARING
  - 13. PISTON BEARING
  - 14. SLEEVE BEARING
  - 15. OUTER SAFETY RING
  - 16. INNER SAFETY RING
  - 17. FLEXIBLE COUPLING ANGE
  - 18. FLEXIBLE COUPLING

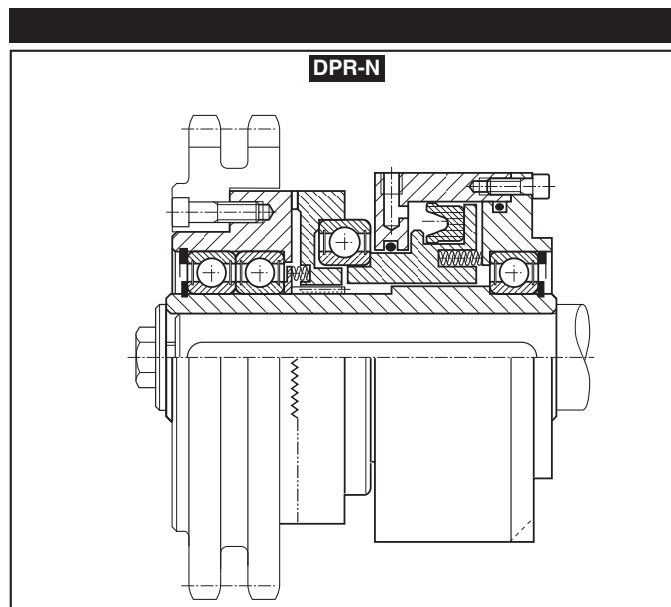



# EMBRAGUE NEUMATICO DE DIENTES NEGATIVO DPR-N

MODEL  
CODE

DPR □□  
03.20.□□.01

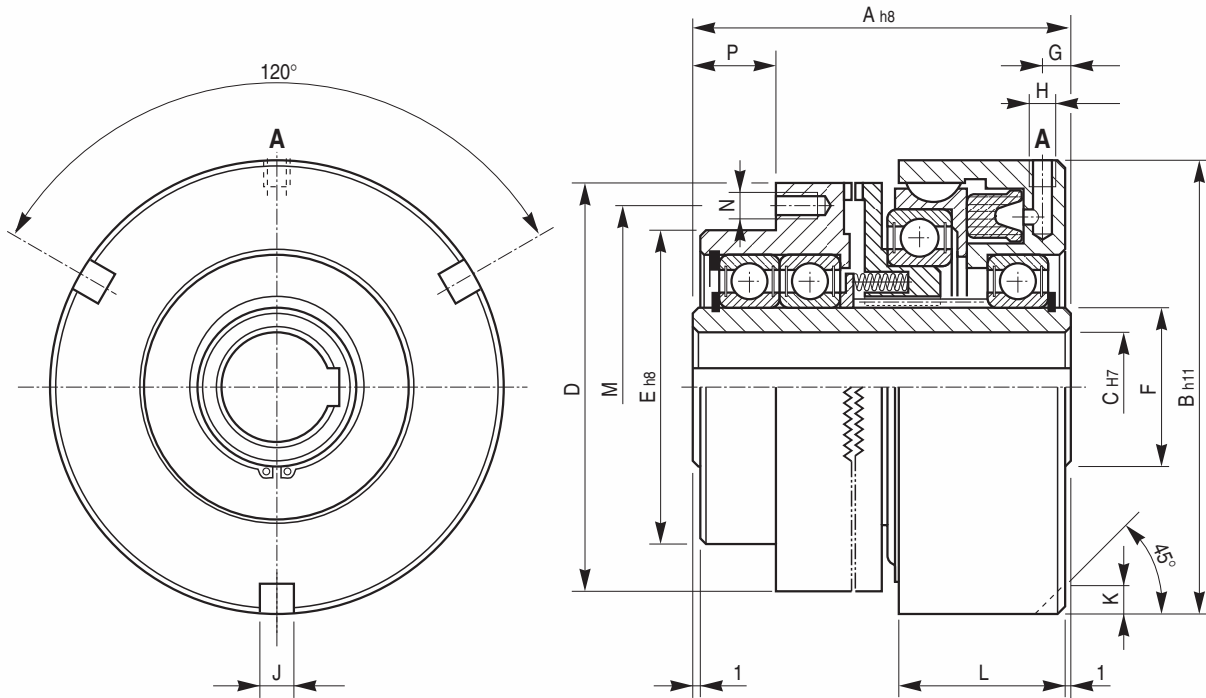

A = Air supply

□□	Torque Ms (Nm)	R.P.M. max.	Working pressure (bar)	Cylinder volume (cm <sup>3</sup> )	Weight (kg)
00	110	3000	6	6	3,4
01	160	3000	6	8	4,1
02	260	2400	6	12	6
03	350	2400	6	15	7,3
04	550	2000	6	25	10,5
05	750	2000	6	30	12,4
06	1300	1600	6	40	18
07	2100	1400	6	50	26

□□	A	B	C		D	E	F	G	H	J	K	L	M	N n° x Ø	P
			min	max											
00	86	97	14	20	92	65	30	7	1/8"	10	9	38	82	3 x M 6	18
01	93	115	15	25	99	72	35	7	1/8"	10	10	46	88	3 x M 6	19
02	98	127	18	34	115	88	45	7	1/8"	10	10	44	102	3 x M 6	20
03	101	134	18	34	124	88	45	7,5	1/8"	10	10	45	108	3 x M 6	20
04	112	153	20	46	137	102	60	9	1/4"	12	12	49	120	6 x M 6	23
05	113	167	25	50	153	112	65	9	1/4"	12	12	55	135	6 x M 8	22
06	129	193	30	60	178	132	75	9	1/4"	12	12	60	155	6 x M 8	23
07	146	216	30	68	209	145	85	9	1/4"	14	14	65	180	6 x M10	32