

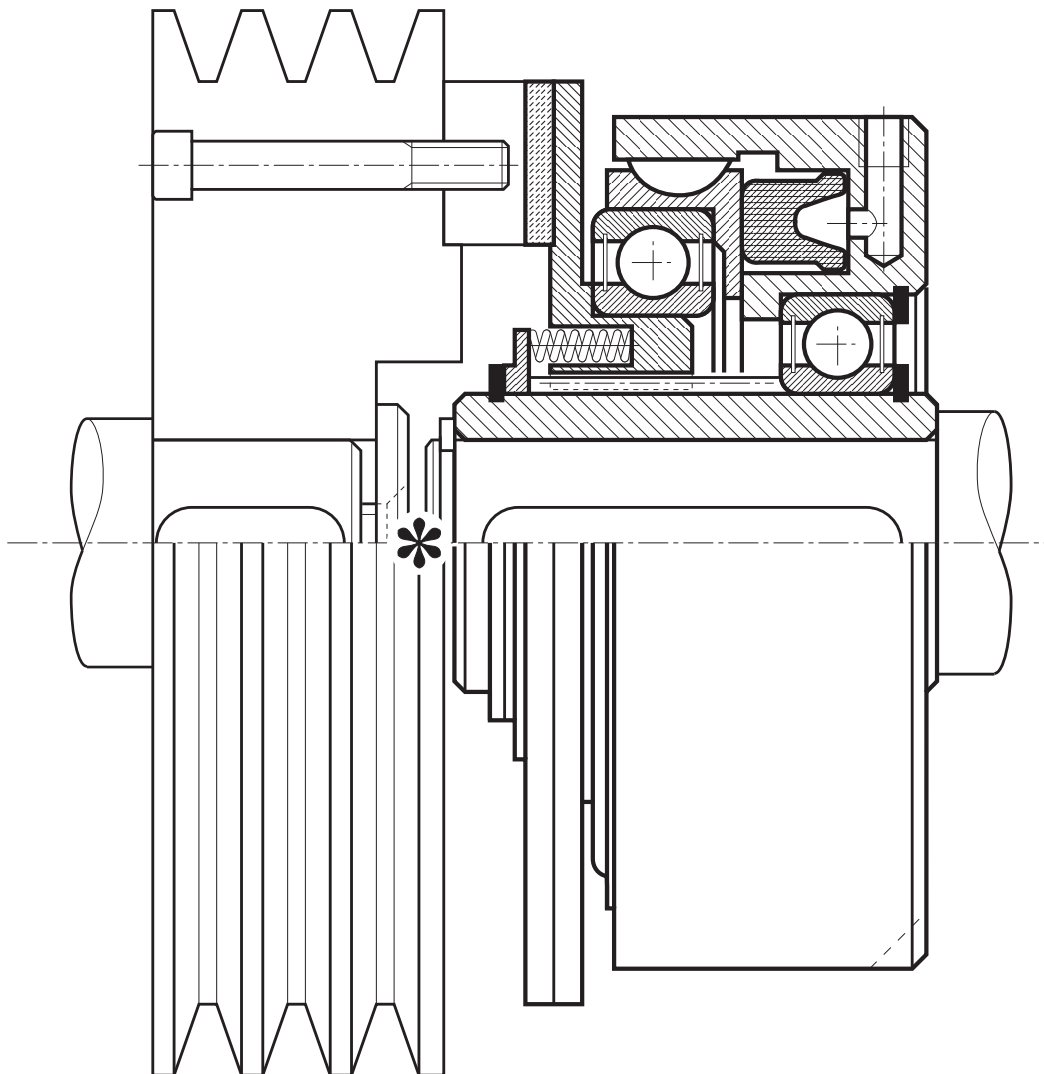

EMBRAGUES NEUMATICOS MULTIDISCO DIRECTOS

MP





EMBRAGUE NEUMÁTICO MULTIDISCO DIRECTO MP

EMBRAGUES NEUMÁTICOS MONODISCO MPR

Estos embragues son adecuados solo para funcionamiento en seco y, por lo tanto, las superficies de fricción no deben entrar en contacto con materiales lubricantes, lo que afecta el par de transmisión.

Si esto ocurre, límpielos con un paño ligeramente humedecido con tricloroetileno o gasolina. La característica principal de estos embragues es que el par es directamente proporcional a la presión de suministro; por lo tanto, el par variará aumentando o disminuyendo la presión. Un conjunto de resortes helicoidales, para contrarrestar la presión de suministro, desconecta completamente la transmisión durante una pérdida de presión total, evitando así el arrastre. Para garantizar que el acoplamiento y, por lo tanto, la transmisión, funcionen correctamente, la presión de suministro siempre debe permanecer constante; por lo tanto, se debe usar un tanque de acumulación para compensar cualquier cambio de presión.

La válvula de control debe montarse lo más cerca posible del orificio de suministro ubicado en el cilindro y también debe estar equipada con un dispositivo de descarga para descargar el pistón y, como consecuencia, que desconecte rápidamente la transmisión.

PNEUMATIC SINGLE-PLATE CLUTCHES MPR

These clutches are suitable only for dry operation and therefore the friction surfaces should not come in contact with lubricating materials, thus affecting the transmission torque. If this occurs, clean them with a cloth slightly moistened with trichlorethylene or gasoline.

The main feature of these clutches is that the torque is directly proportional to the supply pressure; therefore, the torque will vary increasing or decreasing the pressure.

A set of helical springs, to counter the supply pressure, completely disengage the transmission during a total pressure loss, thus avoiding entrainment.

To ensure that the coupling, and therefore the transmission, operates correctly, the supply pressure must always remain constant; therefore, an accumulation tank should be used to compensate for any pressure changes.

The control valve must be mounted as close as possible to the supply hole located on the cylinder and it must also be equipped with a blow-off device to discharge the piston and, as a consequence, to quickly disengage the transmission.



EMBRAGUE NEUMÁTICO MULTIDISCO DIRECTO MP

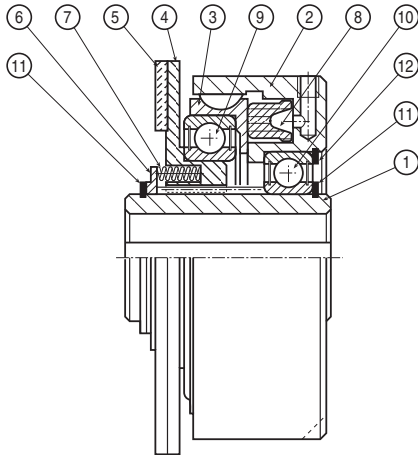

PARTS LIST

- | | |
|----------------------------|-----------------------|
| 1. CENTRAL HUB | 9. PISTON BEARING |
| 2. CYLINDER | 10. HUB BEARING |
| 3. PISTON | 11. OUTER SAFETY RING |
| 4. THRUST RING | 12. INNER SAFETY RING |
| 5. FRICTION RING | |
| 6. SPRING COMPRESSION RING | |
| 7. SPRING | |
| 8. SEAL RING | |

* There must never be any disalignment between the two parts

EXAMPLE OF MOUNTING

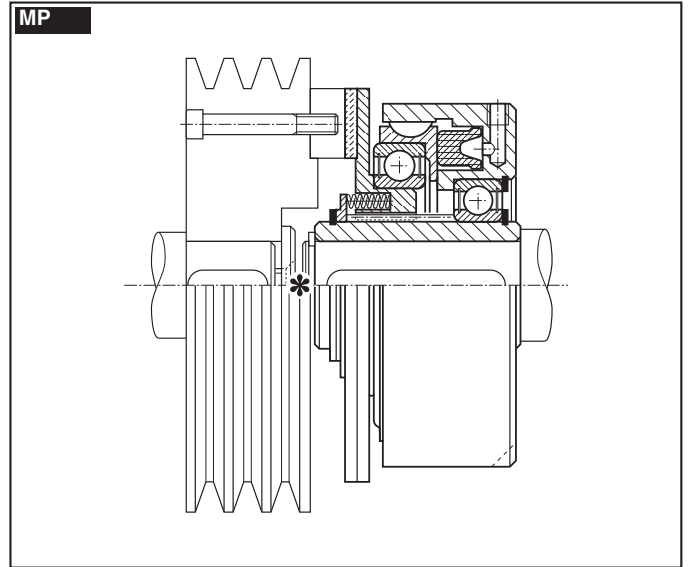

MONTAJE

Al montar, siga nuestras instrucciones y ejemplos.
El cilindro de trabajo debe estar anclado, pero no bloqueado, por medio de una abrazadera o pasador enganchado en una de las tres marcas fresadas de 120° en el cilindro de trabajo mismo; este soporte debe engancharse en el punto fresado más conveniente, en relación con el orificio de suministro de aire, asegurándose de que el cilindro de trabajo tenga algo de juego radial y axial.
Durante la fase de montaje, es muy importante verificar el espacio de aire (Q) en 3 puntos a 120° con un medidor de espesor; debería ser como en las siguientes tablas:

MOUNTING

When mounting, please follow our instructions and examples. The working cylinder must be anchored, but not blocked, by means of a bracket or pin engaged on one of the three 120° milled spots on the working cylinder itself; this bracket is to be hooked onto the most convenient milled spot, in relation to the air supply bore, making sure that the working cylinder has some radial and axial play.
During the assembly phase, it is very important to check the air gap (Q) at 3 points a 120° with a thickness gauge; it should be as specified in the relevant tables.

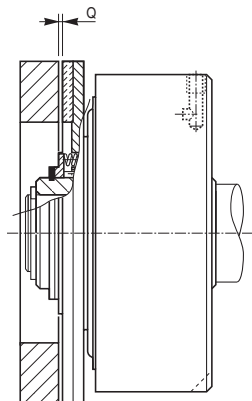

MP		
Size	«Q» Air Gap mm	
00	0,20	0,30
01	0,25	0,35
02	0,30	0,45
03	0,30	0,45
04	0,35	0,50
05	0,35	0,50
06	0,40	0,60
07	0,50	0,70



EMBRAGUE NEUMÁTICO MULTIDISCO DIRECTO MP

PNEUMATIC SINGLE PLATE DRY OPERATING CLUTCH

MODEL	MP □□
CODE	03.15.□□.01

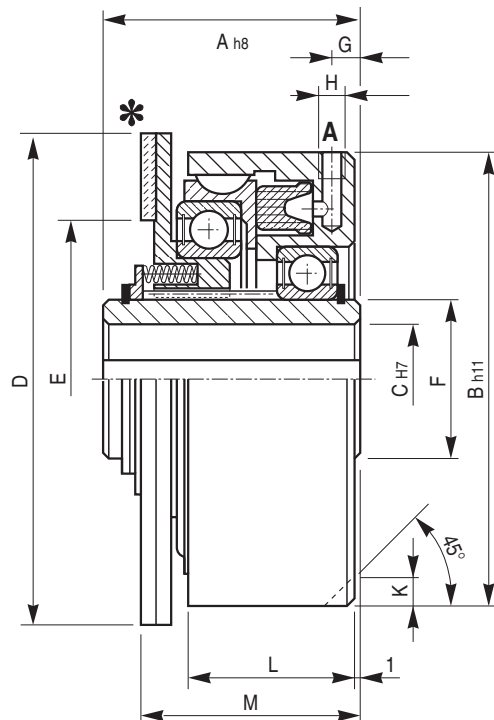
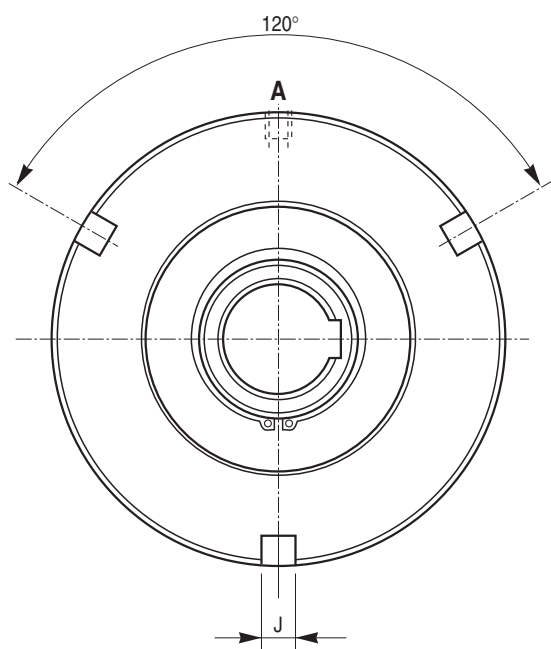

A = Air supply

□□	Torque Ms (Nm)	R.P.M. max.	Working pressure (bar)	Cylinder volume (cm ³)	Axial thrust on the disk (daN)	Weight (kg)
00	20	3000	6	6	136	3
01	30	3000	6	8	200	3,7
02	50	2400	6	12	260	5,5
03	65	2400	6	15	288	6,6
04	100	2000	6	25	442	9,5
05	140	2000	6	30	560	12
06	240	1600	6	40	778	17
07	350	1400	6	50	948	24,8

□□	A	B	C		D	E	F	G	H	J	K	L	M
			min	max									
00	62	97	14	20	112	80	30	7	1/8"	19	9	38	51,5
01	68	115	15	25	118	84	35	7	1/8"	10	10	46	57
02	71	127	18	34	136	102	45	7	1/8"	10	10	44	57,5
03	75	134	18	34	146	102	45	7,5	1/8"	10	10	45	58,5
04	82	153	20	46	168	120	60	9	1/4"	12	12	49	66
05	84	167	25	50	178	126	65	9	1/4"	12	12	55	66,5
06	95	193	30	60	218	162	75	9	1/4"	12	12	60	77,5
07	109	216	30	68	248	188	85	9	1/4"	14	14	65	88