

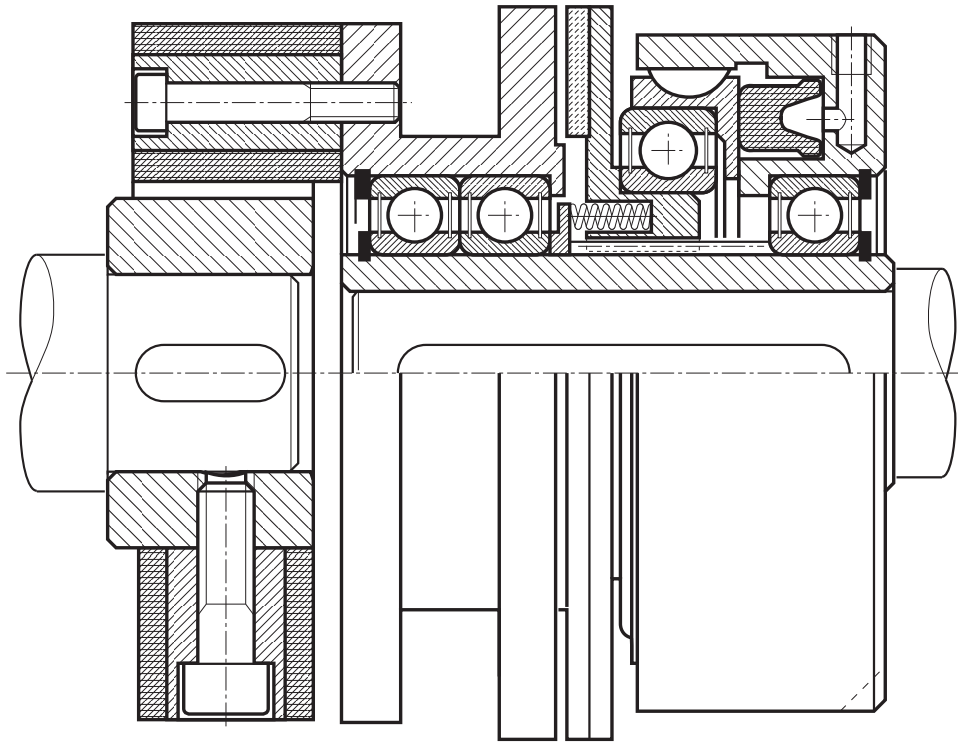

EMBRAGUES NEUMATICOS MULTIDISCO DIRECTOS

MPG





EMBRAGUE NEUMÁTICO MULTIDISCO DIRECTO MPG

EMBRAGUES NEUMÁTICOS MONODISCO MPR

Estos embragues son adecuados solo para funcionamiento en seco y, por lo tanto, las superficies de fricción no deben entrar en contacto con materiales lubricantes, lo que afecta el par de transmisión.

Si esto ocurre, límpielos con un paño ligeramente humedecido con tricloroetileno o gasolina. La característica principal de estos embragues es que el par es directamente proporcional a la presión de suministro; por lo tanto, el par variará aumentando o disminuyendo la presión. Un conjunto de resortes helicoidales, para contrarrestar la presión de suministro, desconecta completamente la transmisión durante una pérdida de presión total, evitando así el arrastre. Para garantizar que el acoplamiento y, por lo tanto, la transmisión, funcionen correctamente, la presión de suministro siempre debe permanecer constante; por lo tanto, se debe usar un tanque de acumulación para compensar cualquier cambio de presión.

La válvula de control debe montarse lo más cerca posible del orificio de suministro ubicado en el cilindro y también debe estar equipada con un dispositivo de descarga para descargar el pistón y, como consecuencia, que desconecte rápidamente la transmisión.

PNEUMATIC SINGLE-PLATE CLUTCHES MPR

These clutches are suitable only for dry operation and therefore the friction surfaces should not come in contact with lubricating materials, thus affecting the transmission torque. If this occurs, clean them with a cloth slightly moistened with trichlorethylene or gasoline.

The main feature of these clutches is that the torque is directly proportional to the supply pressure; therefore, the torque will vary increasing or decreasing the pressure.

A set of helical springs, to counter the supply pressure, completely disengage the transmission during a total pressure loss, thus avoiding entrainment.

To ensure that the coupling, and therefore the transmission, operates correctly, the supply pressure must always remain constant; therefore, an accumulation tank should be used to compensate for any pressure changes.

The control valve must be mounted as close as possible to the supply hole located on the cylinder and it must also be equipped with a blow-off device to discharge the piston and, as a consequence, to quickly disengage the transmission.



EMBRAGUE NEUMÁTICO MULTIDISCO DIRECTO MPG

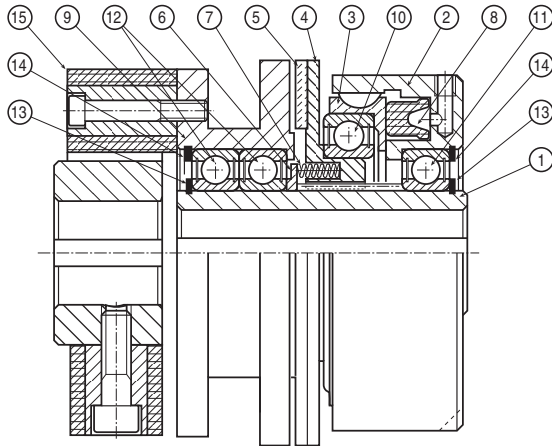

PARTS LIST

- | | |
|----------------------------|-----------------------|
| 1. CENTRAL HUB | 9. TRANSMISSION HUB |
| 2. CYLINDER | 10. PISTON BEARING |
| 3. PISTON | 11. HUB BEARING |
| 4. THRUST RING | 12. SLEEVE BEARING |
| 5. FRICTION RING | 13. OUTER SAFETY RING |
| 6. SPRING COMPRESSION RING | 14. INNER SAFETY RING |
| 7. SPRING | 15. FLEXIBLE COUPLING |
| 8. SEAL RING | |

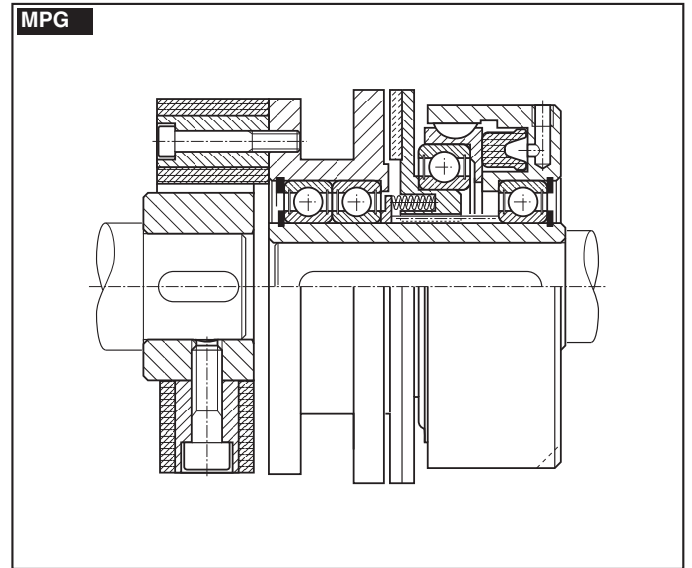

MONTAJE

Al montar, siga nuestras instrucciones y ejemplos.

El cilindro de trabajo debe estar anclado, pero no bloqueado, por medio de una abrazadera o pasador enganchado en una de las tres marcas fresadas de 120° en el cilindro de trabajo mismo;

este soporte debe engancharse en el punto fresado más conveniente, en relación con el orificio de suministro de aire, asegurándose de que el cilindro de trabajo tenga algo de juego radial y axial.

Durante la fase de montaje, es muy importante verificar el espacio de aire (Q) en 3 puntos a 120° con un medidor de espesor; debería ser como en las siguientes tablas:

MOUNTING

When mounting, please follow our instructions and examples. The working cylinder must be anchored, but not blocked, by means of a bracket or pin engaged on one of the three 120° milled spots on the working cylinder itself; this bracket is to be hooked onto the most convenient milled spot, in relation to the air supply bore, making sure that the working cylinder has some radial and axial play.

During the assembly phase, it is very important to check the air gap (Q) at 3 points a 120° with a thickness gauge; it should be as specified in the relevant tables.

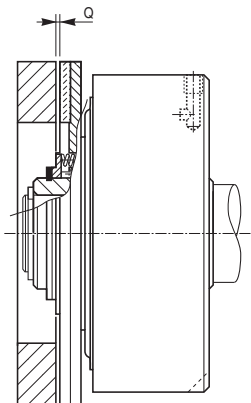

Size	MP	
	«Q» Air Gap mm	
00	0,20	0,30
01	0,25	0,35
02	0,30	0,45
03	0,30	0,45
04	0,35	0,50
05	0,35	0,50
06	0,40	0,60
07	0,50	0,70



EMBRAGUE NEUMÁTICO MULTIDISCO DIRECTO MPG

PNEUMATIC SINGLE-PLATE DRY OPERATING CLUTCH WITH FLEXIBLE COUPLING

MODEL	MPG □□
CODE	03.12.□□.01

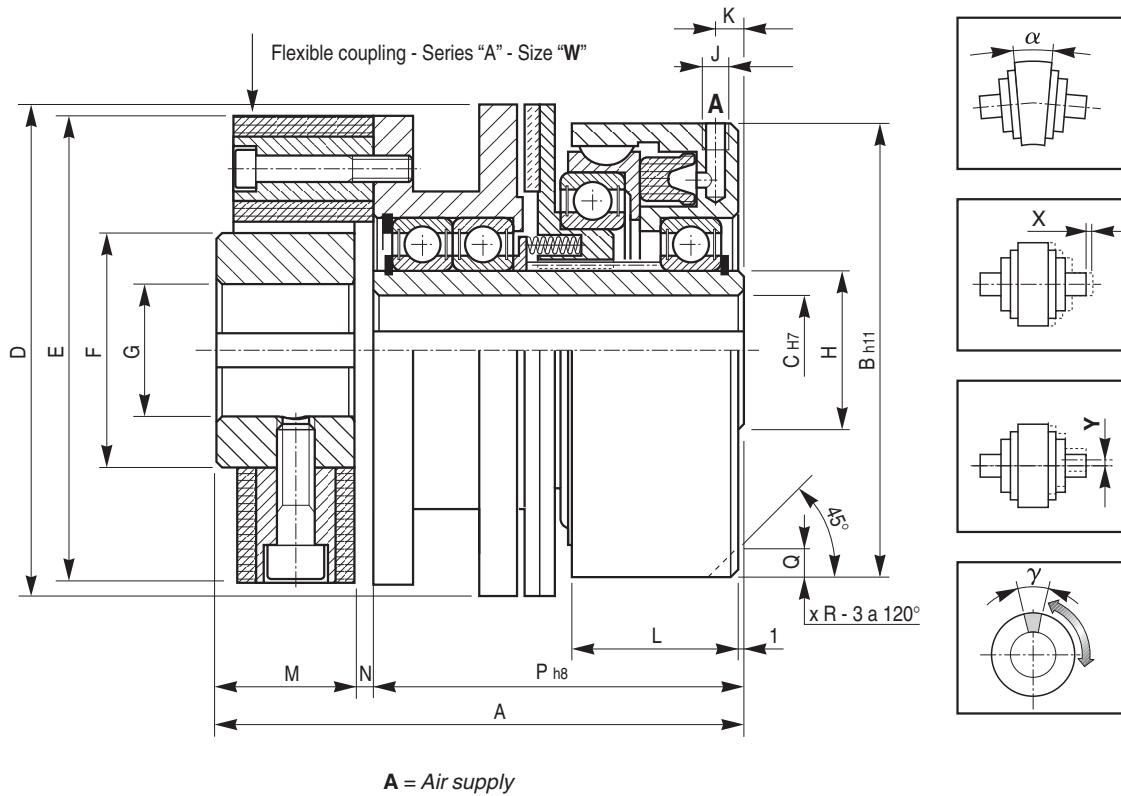

□□	Torque - CLUTCH Ms(Nm)	R.P.M. max	Working pressure (bar)	Cylinder volume (cm ³)	Coupling size W	Weight (kg)
00	20	3000	6	6	2	4,6
01	30	3000	6	8	4	6,5
02	50	2400	6	12	8	8,4
03	65	2400	6	15	8	9,8
04	100	2000	6	25	16	13,6
05	140	2000	6	30	16	15,5
06	240	1600	6	40	25	23,2
07	350	1400	6	50	30	32,7

□□	A	B	min	C	max	D	E	F	min.	G	max	H	J	K	L	M	N	P	Q x R	X	Y	α	γ
00	118	97	14	20	112	85	40	10	26	30	1/8"	7	38	28	4	86	9x10	2	1	1°	9°		
01	127	115	15	25	118	100	45	12	30	35	1/8"	7	46	30	4	93	10x10	2	1	1°	6°		
02	144	127	18	34	136	120	60	12	38	45	1/8"	7	44	42	4	98	10x10	2	1	1°	7°		
03	147	134	18	34	146	120	60	12	38	45	1/8"	7,5	45	42	4	101	10x10	2	1	1°	7°		
04	168	153	20	46	168	150	70	15	48	60	1/4"	9	49	50	6	112	12x12	3	1	1°	7°		
05	169	167	25	50	178	150	70	15	48	65	1/4"	9	55	50	6	113	12x12	3	1	1°	7°		
06	190	193	30	60	218	170	85	15	55	75	1/4"	9	60	55	6	129	12x12	3	1	1°	7°		
07	220	216	30	68	248	200	100	20	65	85	1/4"	9	65	66	8	146	14x14	3	1	1°	7°		