

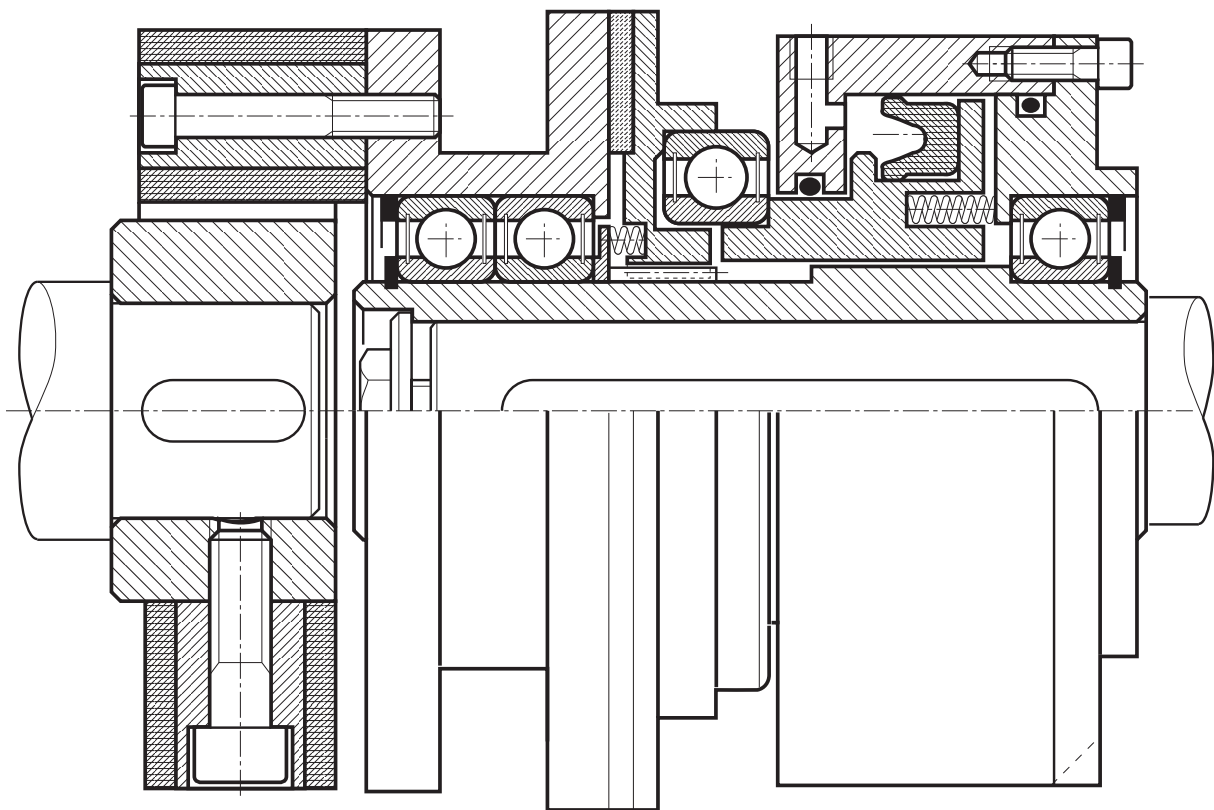

EMBRAGUES NEUMATICOS MONODISCO NEGATIVOS

MPG-N



EMBRAGUE NEUMÁTICO MONODISCO NEGATIVO MPG-N

Estos embragues son adecuados solo para operación en seco y, por lo tanto, las superficies de fricción no deben entrar en contacto con materiales lubricantes, lo que afecta la transmisión del par. Si esto ocurre, límpiense con un paño ligeramente humedecido con tricloroetileno o gasolina.

En condiciones de trabajo, este tipo de embrague se activa mediante la acción de resortes de empuje, que garantizan el par nominal. La desconexión ocurre cuando se suministra aire a presión al cilindro de trabajo a través del orificio de suministro «A» ubicado en el diámetro externo del cilindro de trabajo mismo y por la acción de una segunda serie de resortes de empuje.

Para obtener una desconexión completa del embrague, debe garantizar la presión de liberación sugerida en este catálogo; También sugerimos montar la válvula de comando, que debe estar equipada con un dispositivo de descarga, lo más cerca posible del cilindro de trabajo, para enganchar la transmisión de forma rápida y precisa.

MONTAJE

Al montar, siga nuestras instrucciones y ejemplos. El cilindro de trabajo debe estar anclado, pero no bloqueado, por medio de una abrazadera o pasador enganchado en uno de los puntos fresados en el cilindro de trabajo mismo; este soporte debe engancharse en el punto fresado más conveniente, en relación con el orificio de suministro de aire, asegurando que el cilindro de trabajo tenga algo de juego radial y axial.

Durante la fase de ensamblaje, es muy importante verificar el entrehierro (Q) en 3 puntos a 120° con un medidor de espesor; debe ser como se especifica en las tablas.

- Montar el embrague.
- Desembragar el embrague suministrando aire al cilindro.
- Comprobar la galga.

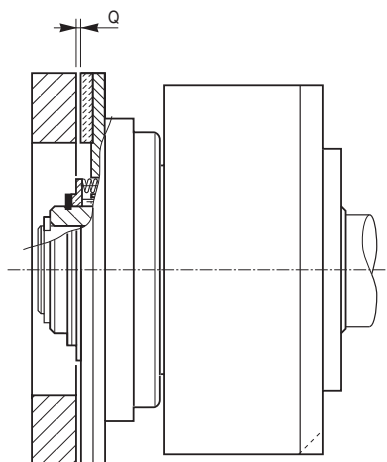

MPG-N PNEUMATIC SINGLE-PLATE SPRING APPLIED CLUTCHES WITH STATIC CYLINDER

These clutches are suitable only for dry operation and therefore the friction surfaces should not come in contact with lubricating materials, thus affecting the transmission of torque. If this occurs, clean them with a cloth slightly moistened with trichloroethylene or gasoline.

In working conditions, this type of clutch is engaged by the action of thrust springs, which guarantee the nominal torque. The dis-engagement occurs when air under pressure is supplied to the working cylinder through the supply bore «A» located on the external diameter of the working cylinder itself and by the action of a second series of thrust springs.

In order to obtain a complete disengagement of the clutch, you must guarantee the release pressure suggested on this catalogue; we also suggest to mount the command valve, which must be equipped with a blow-off device, as close as possible to the working cylinder, to quickly and precisely engage the transmission.

MOUNTING

When mounting, please follow our instructions and examples. The working cylinder must be anchored, but not blocked, by means of a bracket or pin engaged on one of the milled spots on the working cylinder itself; this bracket is to be hooked onto the most convenient milled spot, in relation to the air supply bore, making sure that the working cylinder has some radial and axial play.

During the assembly phase, it is very important to check the air gap (Q) at 3 points at 120° with a thickness gauge; it should be as specified in the relevant tables.

- Mount the clutch.
- Disengage the clutch feeding air to the cylinder.
- Check the air gap.

MPG-N		
Size	«Q» Air Gap mm	
00	0,20	0,30
01	0,25	0,35
02	0,30	0,45
03	0,30	0,45
04	0,35	0,50
05	0,35	0,50
06	0,40	0,60
07	0,50	0,70

MPG-N

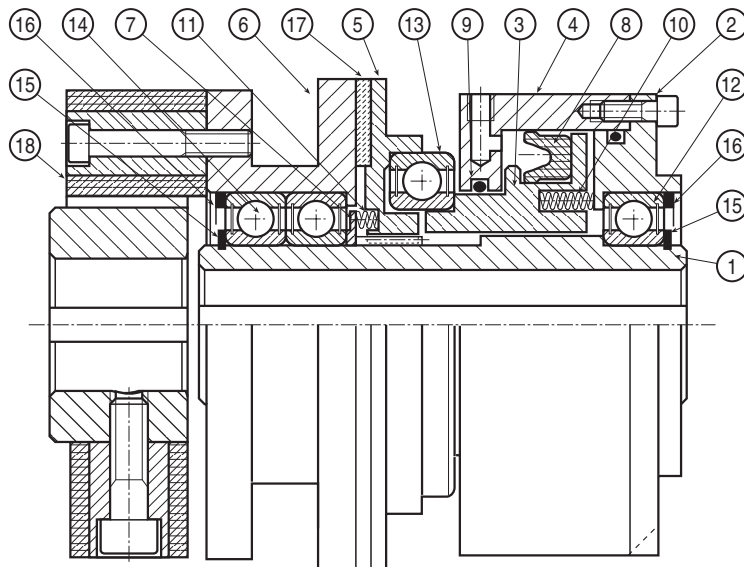

PARTS LIST

1. CENTRAL HUB
2. COVER FLANGE
3. PISTON
4. CYLINDER
5. THRUST RING
6. TRANSMISSION HUB
7. SPRING COMPRESSION RING
8. SEAL RING
9. O-RING
10. SPRING
11. RELEASE SPRING
12. HUB BEARING
13. PISTON BEARING
14. SLEEVE BEARING
15. OUTER SAFETY RING
16. INNER SAFETY RING
17. FRICTION RING
18. FLEXIBLE COUPLING

EXAMPLES OF MOUNTING

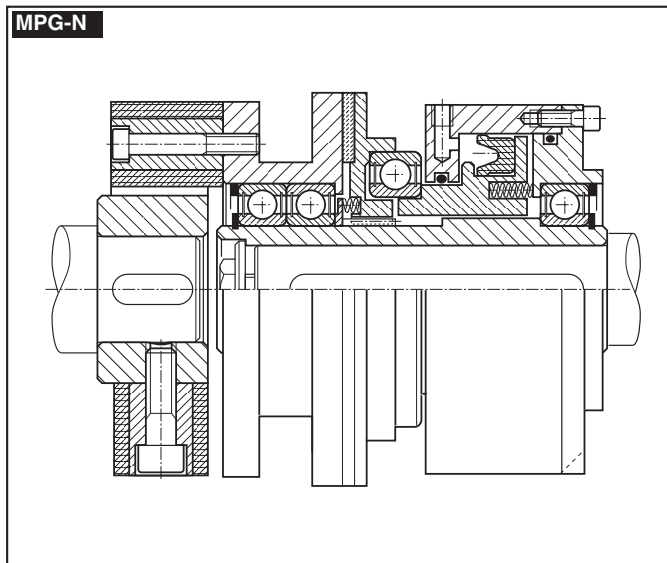

**SINGLE PLATE PNEUMATIC CLUTCH
SPRING LOADED WITH FLEXIBLE COUPLING**

MPG-N ..

03

MODEL	MPG-N □□
CODE	03.52.□□.01

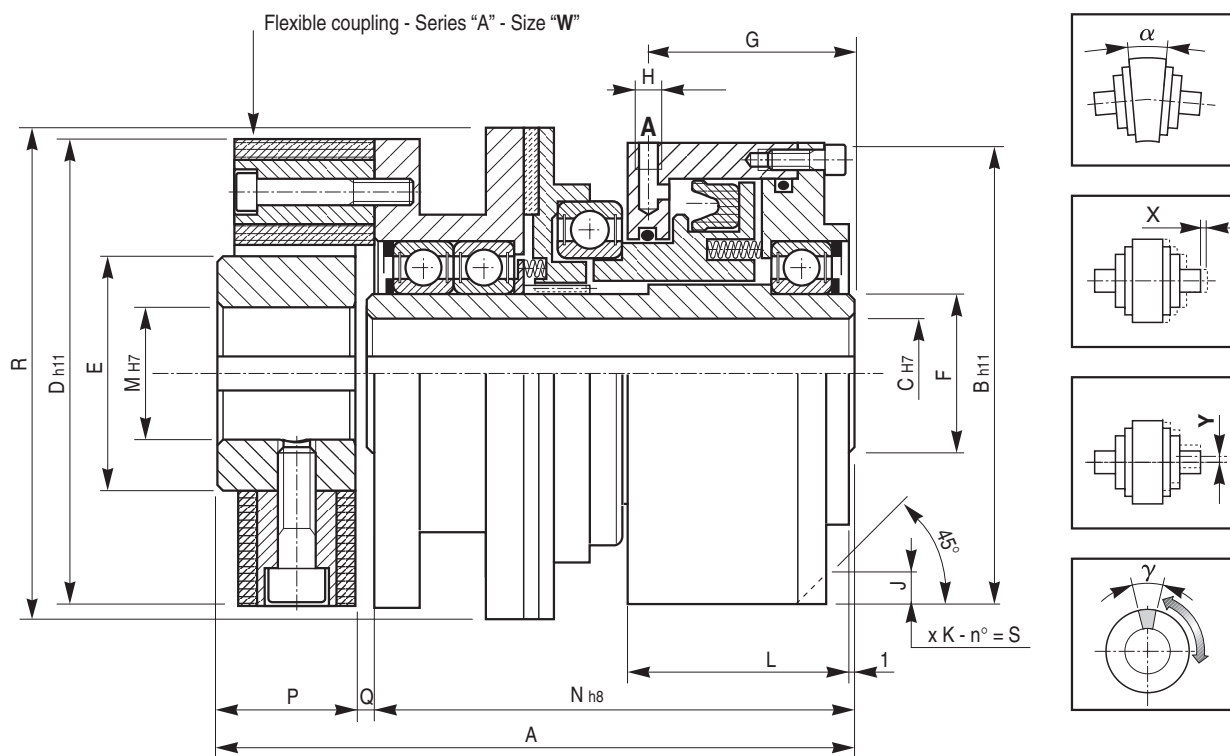

A = Air supply

□□	Torque Ms (Nm)	R.P.M. max	Release pressure (bar)	Cylinder volume (cm³)	Coupling size W	Weight (kg)
00	20	3000	6	7	2	5,2
01	30	3000	6	9	4	7,6
02	50	2400	6	11	8	9,7
03	65	2400	6	13	8	11,8
04	100	2000	6	20	16	18,5
05	140	2000	6	24	16	23,2
06	240	1600	6	35	25	33,9
07	350	1400	6	42	30	46,4

□□	A	B	min	C max	D	E	F	G	H	J x K	L	min	M max	N	P	Q	R	S	X	Y	α	γ
00	146	108	14	20	85	40	30	48	1/8"	6x6	54	10	26	114	28	4	112	3	2	1	1°	9°
01	154	123	15	25	100	45	35	51	1/8"	8x8	57	12	30	120	30	4	118	3	2	1	1°	6°
02	174	138	18	34	120	60	45	55	1/8"	8x8	61	12	38	128	42	4	136	3	2	1	1°	7°
03	181	145	18	34	120	60	45	58	1/8"	8x8	64	12	38	135	42	4	146	3	2	1	1°	7°
04	206	178	20	46	150	70	60	63	1/8"	9x9	70	15	48	150	50	6	168	3	3	1	1°	7°
05	216	198	25	50	150	70	65	70	1/4"	10x10	78	15	48	160	50	6	178	3	3	1	1°	7°
06	233	228	30	60	170	85	75	74	1/4"	10x10	82	15	55	172	55	6	218	4	3	1	1°	7°
07	259	248	30	68	200	100	85	78	1/4"	10x10	86	20	65	185	66	8	248	4	3	1	1°	7°