

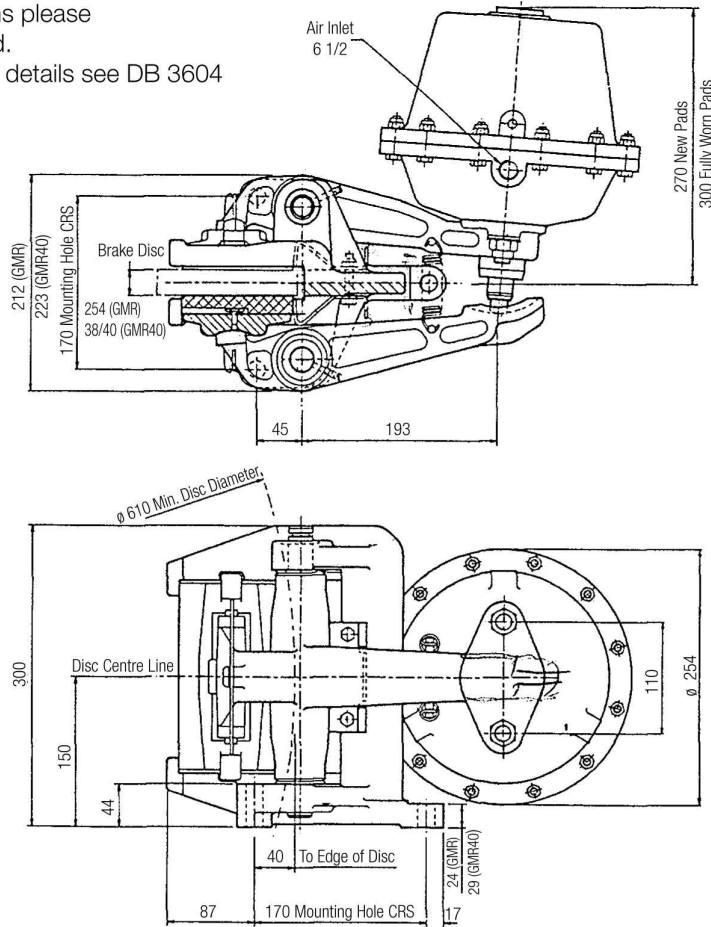

GMR-S and GMR40-S Disc Brake Caliper - Spring Applied, Air Released

DB4603

Nominal dimensions given.
For specific dimensions please
contact Twiflex Limited.
For GMR Mk 2 caliper details see DB 3604



Note:

The caliper may be assembled as drawn (right hand assembly) or with arms and thruster oppositely handed.

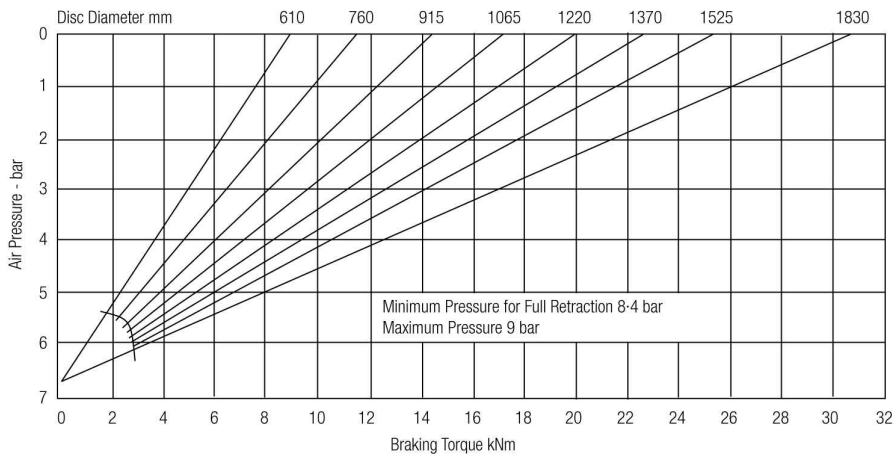

The ratings shown on the above graph are based on fully bedded and conditioned brake pads. For bedding in and conditioning procedures see Publication M1060.

Braking Force is defined as the Tangential Force acting on the brake disc at the Effective Disc Radius.

Braking Torque (Nm) = Braking Force (N) x Effective Disc Radius (m)

where Effective Disc Radius = Actual Disc Radius- 0.06



GMR-S and GMR40-S Disc Brake Caliper - Spring Applied, Air Released

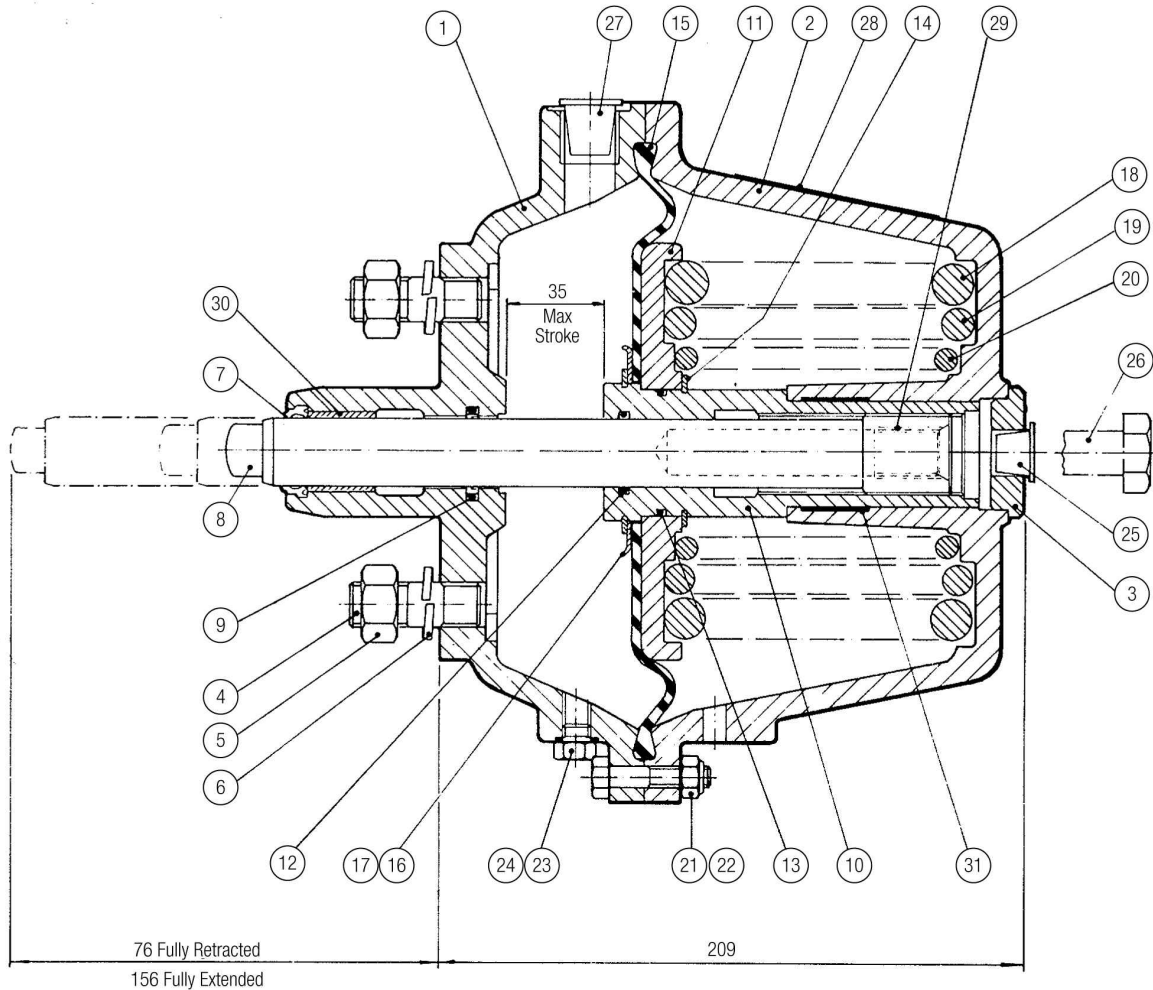

Thruster Type - S

Maximum Displacement Volume 1.3 l.

Parts List

Item	Component	Part No.	Qty.
1	Front Cap		1
2	Rear Cap		1
3	Thrust Collar		1
4	Stud		1
5	M16 Nut		2
6	M16 Spring Washer		2
7	Wiper Seal	600242	1
8	Pushrod		1
9	Rod Seal	600243	1
10	Sleeve		1
11	Spring Plate		1
12	'O' Ring	600138	1
13	'O' Ring	600224	1
14	Circlip		1
15	Diaphragm	7200776	1
16	Support Plate		1

Item	Component	Part No.	Qty.
17	Spring Ring		1
18	Main Spring		1
19	Centre Spring		1
20	Inner Spring		1
21	M8x 35 Bolt		12
22	M8 Nut		12
23	G 1/8 Plug		1
24	G 1/8 Washer		1
25	Redcap		1
26	Retraction Screw		1
27	G 1/2 Redcap		1
28	Label		1
29	Helicoil Insert		1
30	Bush	1800372	1
31	Bush	1800374	1



GMR-S and GMR40-S Disc Brake Caliper - Spring Applied, Air Released

The GMR-S and GMR40-S calipers are available in various ratings, as shown on the performance charts.

Part numbers are given below.

These are typical performance figures for bedded and conditioned brake pads having a friction coefficient of 0.4 when used with standard Twiflex discs an appropriate 'service factor' should be applied when designing the braking system and in the case of brakes used for holding duties or in wet conditions this should be not less than 2.0.

Marinised versions of the calipers, and thrusters with nodular cast iron castings (instead of aluminium alloy) are available to special order.

A monitoring unit is also available (Part No. 7700212) which is fitted to the back of the thruster. The unit incorporates two microswitches, of which one indicates full retraction of the pushrod (i.e. brake off) and the other indicates the need for adjustment due to pad wear.

Thruster Type	Thruster Part No.	Thruster Weight Kg	Max. Braking Force kN	Retraction Air Pressure Bar	Caliper Part No.	
					GMR	GMR40
S 8.4	7200777	12.2	19.5	4.8	6780971	6781006
S 11	7200807	13.2	25	6.0	6780971	6781006
S 12-9	7200806	14	30	7.0	6780971	6781006
S 15-6	7200805	15	36	8.4	6780971	6781006

Installation, Operation and Maintenance

1. Installation

- 1.1 The caliper must be mounted on a suitably rigid support, upon which braking forces of up to 36kN will be imposed.
- 1.2 The caliper should be positioned symmetrically with respect to the disc, as shown on the drawing.
- 1.3 Three fixing bolts are required, M16 grade 8.8. The bolts should be tightened to a torque of 150Nm.
- 1.4 If the caliper is to be mounted on an inclined surface, the caliper should be fitted with adjustable stop screw and bias springs, included in the inclined mounting kit (Part Number 6700458, drawing number A11074).
- 1.5 Calipers are normally supplied assembled 'right-handed', as shown on the drawing, unless otherwise specified.
- 1.6 The thruster is normally supplied separately from the caliper, and with the retraction screw fitted to hold it in the 'off' position (see section 2.2) until it has been fitted on the caliper arm. Nuts and washers for this purpose are supplied and should be tightened to 45Nm torque. Thrusters are normally fitted with the air inlet uppermost.
- 1.7 The air inlet connection on the thruster is tapped G 1/2 (1/2" BSP). The air supply should be connected via a length of flexible tubing to accommodate the movement during operation. A quick exhaust valve may be fitted if very rapid brake operation is required.
- 1.8 Control of brake operation is effected by a 3 port, 2 position valve with open exhaust. Standard 'Twiflex' controllers, with electrical, pneumatic or hydraulic signalling are available if required.
- 1.9 The air supply used should be dry and oil free if possible; operation of the thruster at full stroke requires approximately 1.3 litres of compressed air.

2. Operation

- 2.1 The brake is applied by the thruster springs and released pneumatically. The required supply pressure varies with the caliper rating and is given on the performance charts. Variable braking torque can be achieved by regulating the air pressure as shown on the charts.
- 2.2 To enable the brake to be released in the event of air supply failure, a retraction screw is supplied (M16 x 130, Part number 5350249). This is inserted into the rear of the thruster and screws directly into the end of the pushrod; adequate access to the back of the thruster is required. The retraction screw is also used as the safety screw during maintenance.
- 2.3 THE RETRACTION SCREW SHOULD BE REMOVED COMPLETELY WHEN THE BRAKE IS IN SERVICE, and the red plastic cap supplied fitted in the hole. (The brake should be off i.e. pressurised, when removing the retraction screw).
- 2.4 THE THRUSTER STROKE SHOULD BE MAINTAINED AT ABOUT 20mm BY UNSCREWING THE PUSHROD. To adjust, the brake must be off (i.e. air pressure on). Pull the caliper arm away from the pushrod and turn the rod as required; one turn gives 2mm adjustment. Release the caliper arm, ensuring that the flats on the push rod are engaged in the slot in the caliper arm. (A 17mm A/F spanner will fit the flats on the pushrod).



GMR-S and GMR40-S Disc Brake Caliper - Spring Applied, Air Released

N.B. Keep fingers clear of the space between push rod and caliper arm at all times.
If an inclined mounting kit is fitted, the stop screw should be re-adjusted to maintain equal pad clearance on either side of the disc.

- 2.5 Pad wear can be monitored by observing the gap between the lugs on the pads pressure plates and the machined surfaces on the caliper frame, when the brake is applied. Pads must be replaced (see 3.2) before the gap is reduced to zero. The maximum allowable wear on a pad is 10mm).

3. Maintenance

CALIPER

- 3.1 Ensure that the brake pad and disc remain free from oil and grease. Clean the disc as required. If the pads become contaminated they should be replaced. Carry out any periodic statutory testing that is required, or otherwise check for satisfactory performance.
- 3.2 Pad replacement is carried out from the rear of the caliper; DO NOT release the spring clips which attach the pressure plates to the caliper arms. With the brake off (retraction screw may be fitted as a safety screw) remove the caliper return springs and the keep plates. If an inclined mounting kit is fitted, remove this also. Withdraw the pads to the rear and lift out. (The hole in the end of the pad retaining plates is provided to assist in withdrawing the pads). Fit the new pads (part number 7080080), ensuring that the slotted retaining plate is located around the keep disc on the pressure plate; the pads should slide freely into position. Replace remaining parts. Re-adjust the push rod, as in (2.4), and the stop screw if fitted.
- 3.3 The surface of the caliper arm on which the thruster pushrod bears should be kept well greased. The knuckle joints between the caliper arms and the pressure plates should be cleaned occasionally, and a small amount of grease applied; the joints may be levered apart slightly against the pressure of the spring clip. Occasionally, or if caliper is not operating freely, inject a small amount of grease via grease-nipples to lubricate the pivot pins, then rotate pins to distribute the grease. Any grease exuding past the 'O'-rings should be wiped off. The pins may be turned by gripping the knurled end at the top of the caliper.

After extended one million operations or three years) use, the pivot pins should be withdrawn, cleaned, replaced and regreased, or replaced if badly worn.

In order not to damage the O-ring seals on the pins, use the following procedure. Remove the top circlip, push pin down until the lower circlip and 'O'-ring can be removed, then withdraw the pin upwards. To refit, reverse this procedure.

THRUSTER

- 3.4 Clean the push rod as required. If the air supply is wet, the drain plug (23) should be removed at intervals to release any accumulated water.

In the event of leakage or malfunction of the thruster, the following parts can be inspected and replaced if necessary, using the procedures described below, without decompressing the spring pack:-

- Diaphragm (15)
- Rod Seal (9)
- Bush (30)
- Wiper Seal (7)
- Push rod (8)

- 3.5 Replacement of any other component, i.e. O-rings (12), (13), bush (31) and springs requires the spring pack to be decompressed. This is not covered in these instructions, and should only be carried out by Twiflex or their agents. If the pushrod is known to be damaged, replace it first, as in 3.11. Otherwise proceed as below.

WARNING:- DO NOT ATTEMPT TO DECOMPRESS THE SPRINGS BY UNSCREWING THE RETRACTION SCREW.

Thruster Servicing

- 3.6 With the brake off, insert retraction screw and screw it fully in; finger tight is sufficient. (If thruster will not retract, the brake should be released using the retraction screw, which should be well lubricated). Disconnect the air supply and remove thruster from caliper.

Adjust the retraction screw to allow a thruster stroke of approximately 32mm (i.e. just under full stroke). This adjustment allows the diaphragm to assume its natural shape, which eases re-assembly. The use of a temporary air supply will be found convenient, as it avoids having to turn the retraction screw under load.

Withdraw the bolts (21), and remove the front cap (1), spring ring (17), support plate (16) and diaphragm (15). The diaphragm should be free from splits or cracks, but some wear from the edge of the spring plate (11) is acceptable if the fabric reinforcement is not damaged.



GMR-S and GMR40-S Disc Brake Caliper - Spring Applied, Air Released

- 3.7 Leakage of air past the rod seal may be caused by damage to the seal or to the pushrod. The surface of the pushrod must be smooth and free from scoring or bruising. Note that the pushrod cannot be removed whilst the thruster is dismantled. (For removal and replacement of the push rod see 3.11 below).

The rod seal (which has two parts, the P.T.F.E. sealing ring and an O-ring) may be removed using a small screwdriver or similar tool. Take care not to damage the groove. Once removed the seal should not be re-used.

When fitting a new seal, the P.T.F.E. ring must be compressed, which requires the use of a fitting tool; see drawing A21123. Note that the stepped side of the ring is the pressure side.

- 3.8 The wiper seal (7) serves both to retain grease and to exclude dirt. The section of the pushrod which moves through the wiper seal should be cleaned with a very slight lubricant film. The wiper seal is of all rubber construction and is easily replaced without tools.
- 3.9 The bush (30), which is pressed into the front cap, has a number of shallow circular indentations in its surface, which retain grease. The limit of acceptable wear on the bush is 0.2mm, approximately half the depth of the indentations in a new bearing.

A worn bush can be withdrawn (after removal of the wiper seal which may be re-used unless damaged) using a suitable extractor. The new bush, should be pressed in until flush with the base of the wiper seal recess.

- 3.10 Re-assembly of the thruster is the reverse of dismantling. Seals should be lightly greased to ease assembly; the grease reservoir groove in the front cap and the bush indentations should be filled with grease.

Ensure that the beaded edge of the diaphragm locates correctly in the grooves, and tighten the bolts progressively until flanges are in contact all round.

After re-assembly, pressurise the thruster and check for leaks. Using the retraction screw to maintain full retraction, refit the thruster to the caliper. (After removing the retraction screw replace the red plastic cap in the hole).

Push rod removal/replacement Re-Lubrication of Thruster

- 3.11 With the thruster removed from the caliper (as in 3.6), remove the retraction screw, so that the thruster operates through its full stroke, and the spring load is supported on the front cap. Remove the thrust collar (3) from the rear cap (2). This is a light press fit.

Unscrew the pushrod until it can be withdrawn through the rear of the thruster. Clean and examine the push rod, replace if damaged. Clean other parts.

Re-lubricate the front cap bearing, the internal thread of the sleeve (10), the rear cap bore adjacent to the end of the sleeve, and the threads (internal and external) of the push rod, with grease.

Re-fit the pushrod into the thruster and replace the thrust collar (if it is loose, use a low-strength grade of 'Loctite' to retain it). Pressurise the thruster, check for leaks and fit the retraction screw. Re-fit the thruster to the caliper. (After removing the retraction screw, replace the red plastic cap into the hole).

4. Recommended Lubricants

- 4.1 Caliper: Medium grease containing Molybdenum disulphide.
e.g. Castrol LMM
Shell Alvania 2 + MoS²
- 4.2 Thruster: Medium lithium based grease with rust inhibitors
e.g. Duckham's Keenomax L2
Castrol AP 2
Shell Alvania R2

5. Spares

- 5.1 A spare set of brake pads, a diaphragm and a set of seals should be kept in a cool, dry, dark place where there is no chance of contamination.
- 5.2 For caliper spares see Data Sheet DB 3604.
- 5.3 Spare components for air-line equipment, including the filters and the controller should be kept in readiness, as appropriate.

6. Service

Address all enquiries regarding this equipment to your Twiflex agent or direct to Twiflex Limited.



GMR-S and GMR40-S Disc Brake Caliper - Spring Applied, Air Released

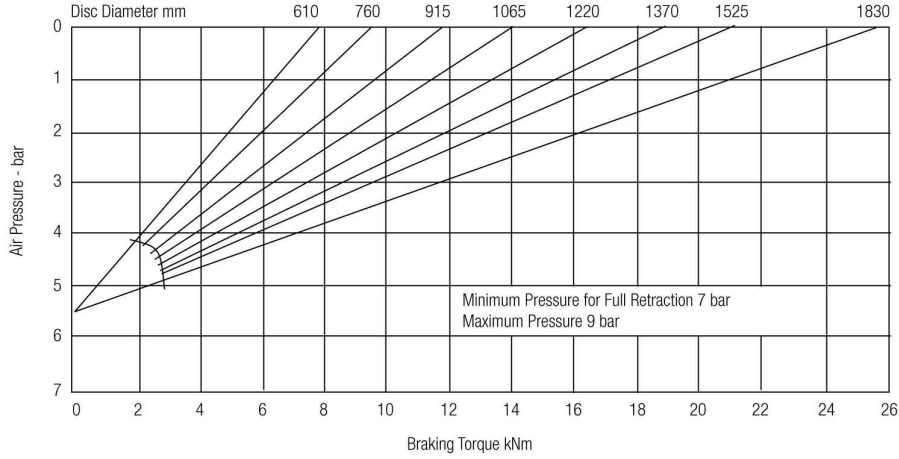

Brake performance at 30 kN braking force

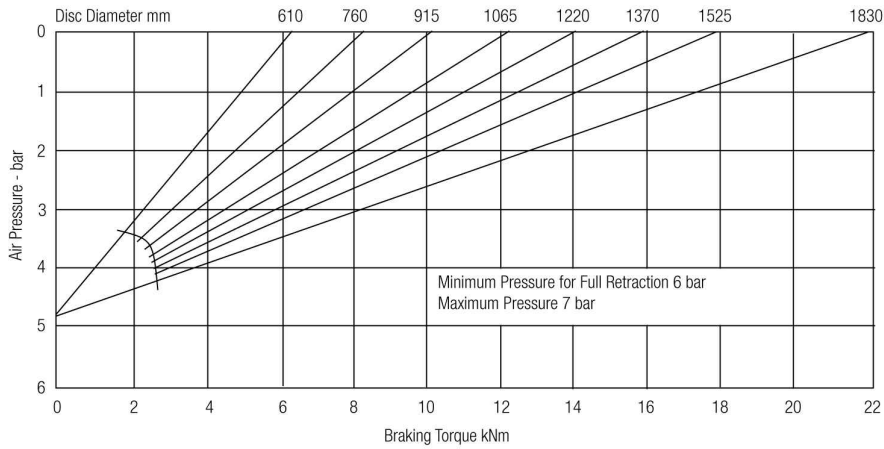

Brake performance at 25 kN braking force

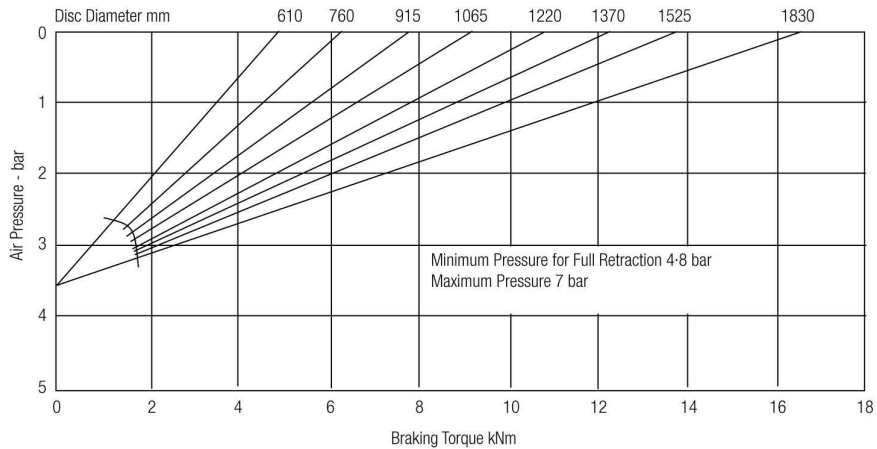

1 kNm = 736.6 lbf-ft 1 bar = 14.5 psi

Brake performance at 19.5 kN braking force



INSTALLATION, OPERATION AND MAINTENANCE INSTRUCTIONS

MANUAL M1477_UK

**GMR-SD & GMR40-SD
DISC BRAKE CALIPER**

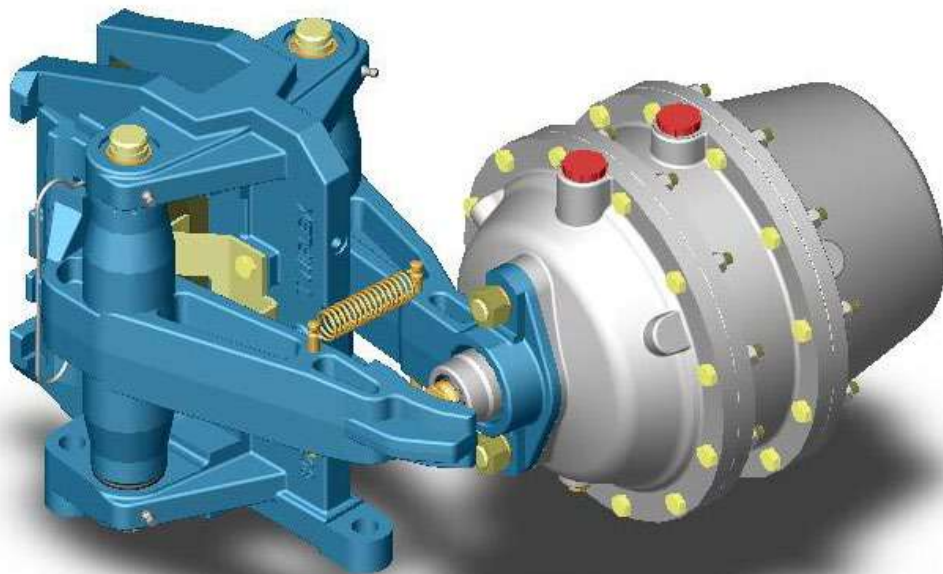

Note:

This manual is a general installation and maintenance manual. Actual brakes / calipers may differ from those illustrated.

The reference drawings show general dimensions. For customized versions, corresponding design drawings are authoritative.

M1477_UK – Original manual
M1477_DE – Translation



**AMENDMENT AND REVISION RECORD
M1477**

AMENDMENT NUMBER ISSUE AND DATE			SIGNATURE AND DATE WHEN AMENDMENT ISSUED
	01	1 / 2006	S.POWELL
13588	02	13/03/07	R. GOULD
13874	03	13/08/09	S.POWELL
13963	04	03/08/10	A. DAVIS
2775	05	21/10/15	R. HEINSEN
---	06	08/09/17	M. DAMRELL



LIST OF CONTENTS

- 1. GENERAL**
 - 1.1 Description
 - 1.2 Part Identification
 - 1.2.1 GMR Caliper
 - 1.2.2 SD Thruster
 - 1.3 Performance Data

- 2. INSTALLATION**
 - 2.1 Caliper Installation
 - 2.2 Inclined Mounting Kit
 - 2.3 Thruster Installation and Setting
 - 2.4 Monitor Unit
 - 2.5 Brake Pad Conditioning

- 3. OPERATION**
 - 3.1 General
 - 3.2 Manual Retraction
 - 3.2.1 Without Monitoring Unit
 - 3.2.2 With Monitoring Unit

- 4. MAINTENANCE**
 - 4.1 Maintenance Schedule
 - 4.1.1 Monthly Maintenance
 - 4.1.2 Periodic Maintenance
 - 4.2 Routine Maintenance
 - Caliper**
 - 4.2.1 Pad Replacement
 - 4.2.2 Pivot Pin Replacement
 - 4.2.3 Recommended Lubricants
 - Thruster**
 - 4.2.4 Push Rod Removal / Replacement
 - 4.2.4.1 Without Monitoring Unit
 - 4.2.4.2 With Monitoring Unit
 - 4.2.5 Stripdown and Seal Replacement
 - 4.2.5.1 Without Monitoring Unit
 - 4.2.5.2 With Monitoring Unit
 - 4.2.6 Recommended Lubricants
 - 4.3 Major Service
 - 4.3.1 Removal of the Spring Pack
 - 4.3.1.1 Without Monitoring Unit
 - 4.3.1.2 With Monitoring Unit
 - 4.3.2 Assembly of Spring Pack

- 5. RECOMMENDED SPARES**



FIGURES

1. Twiflex GMR-SD Disc Brake Caliper
2. GMR Brake Caliper: Basic Parts
3. SD Thruster: Basic Parts
4. Inclined Mounting Kit
5. Thruster Setting
6. Manual Retraction Screw
7. Monitor Unit - 7701384, 7701394, 7701395, 7701442
8. Return Springs Released
9. Keep Plate(s) Removal
10. Replace Pads
11. Pivot Pin Replacement
12. Push Rod Removal
13. Front Cap Removed
14. Centre Casing Removed
15. Hydraulic Press with SD Thruster mounted
16. Assembly Compression and Guide Tools
17. Equipment Layout
18. Retraction Screw removed
19. Monitor Unit Cover Removal
20. Assembly Guide Tool
21. Assembly Equipment Layout
22. GMR Caliper Recommended Spares
23. SD Thruster Recommended Spares

TABLES

1. SD Thruster suitable for Monitor Unit 7700263
2. SD Thruster suitable for Monitor Unit 7701384, 7701394, 7701395, 7701442
3. GMR Caliper – Basic Parts
4. Friction Pad Assemblies
5. SD Thruster – Basic Parts
6. Spring Pack
7. Seal Kit
8. Inclined Mounting Kit

DRAWINGS (to be used in conjunction with this manual - M1477)

- | | |
|--------|---------------------------|
| A11046 | Thruster Type SD |
| A01180 | GMR Caliper Assembly |
| A01221 | GMR40 Caliper Assembly |
| A11210 | Monitor Unit |
| A21123 | Seal Fitting Kit |
| A21160 | Assembly Compression Tool |
| A32151 | Assembly Guide |
- A01601, A01674, A01684 Electrical Monitor Unit (proximity sensor)

1. GENERAL

1.1 Description

- 1.1.1 This manual contains the Installation, Operation and Maintenance instructions for the Twiflex GMR-SD and GMR40-SD disc brake caliper.

The GMR-SD disc brake comprises a GMR caliper and SD thruster which is suitable for a disc thickness of 25mm.

The GMR40-SD disc brake comprises a GMR40 caliper and SD thruster which is suitable for a disc thickness of 40mm.

The minimum disc diameter for both calipers is 610mm but there is no limit on the maximum diameter.



FIGURE 1 – Twiflex GMR-SD disc brake caliper

Both the GMR-SD and GMR40-SD disc brake calipers are spring applied, air released and produce a maximum tangential braking force of 36 kN at a nominal thruster stroke of 20mm.

By removing springs from the thruster the braking force can be reduced to 10 kN. The range of thrusters use dry and filtered compressed air at pressures from 1.4 to 4.6 bar depending on the spring setting. A total of five spring settings are available (see Tables 1 & 2).

Both mechanical (microswitch) and electrical (inductive proximity sensor) monitor units are available (see Para 1.1.2)



Thruster Type	Thruster Part No.	Thruster Mass * (Kg)	Max. Braking Force (kN)	Retraction Air Pressure (Bar)	Caliper Part No. GMR	Caliper Part No. GMR40
SD 4.5	7201265	17.7	10.5	1.4	6780971	6781006
SD 8.4	7200924	18.2	19.5	2.4	6780971	6781006
SD 11	7200811	19.2	25	3.3	6780971	6781006
SD 12.9	7200810	20.0	30	3.8	6780971	6781006
SD 15.6	7200778	21.0	36	4.6	6780971	6781006

TABLE 1 – SD Thruster suitable for Monitor Unit 7700263

Thruster Type	Thruster Part No.	Thruster Mass * (Kg)	Max. Braking Force (kN)	Retraction Air Pressure (Bar)	Caliper Part No. GMR	Caliper Part No. GMR40
SD 4.5	7201265 / BA07	17.7	10.5	1.4	6780971	6781006
SD 8.4	7200924 / AY19	18.2	19.5	2.4	6780971	6781006
SD 12.9	7200810 / AY18	20.0	30	3.8	6780971	6781006
SD 15.6	7200778 / AY17	21.0	36	4.6	6780971	6781006

TABLE 2 – SD Thruster suitable for Monitor Units 7701384, 7701394 7701395 and 7701442

1.1.2 Monitor Units

Mechanical Type (Twiflex Part No. 7700263)

Includes microswitches to indicate 'Full Retraction' plus 'Stroke Adjustment' reqd.

Electrical Type

D.C. Unit (Twiflex Part No. 7701384)

Three function, all N.O. proximity sensors.

'Full Retraction' and 'Stroke Adjustment Required'.

A further switch provides a signal which can be used to initiate shutdown if adjustment has not been made i.e. 'Out of Adjustment'.

D.C. Unit (Twiflex Part No. 7701394)

Three function, 1off N.O. proximity sensors (Full Retraction) plus 1off N.C. 'Stroke Adjustment Required' and 1off N.C. 'Out of Adjustment'.

D.C. Unit (Twiflex Part No. 7701395)

Single function, 1off N.O. proximity sensor (Full Retraction).

A.C. Unit (Twiflex Part No. 7701442)

Three function, 1off N.O. proximity sensors (Full Retraction) plus 1off N.C. 'Stroke Adjustment Required' and 1off N.C. 'Out of Adjustment'.



1.2 Part Identification

1.2.1 GMR CALIPER (see Figure 2)

See Twiflex Drawing A01180 (GMR) and A01221 (GMR40)

TABLE 3 – GMR Caliper Basic Parts

Item	Description	Part Number	Qty
1	Pivot base GMR	8030028	1
	Pivot Base GMR 40	8030028	1
2	Arm – thruster side	6630189	1
3	Arm – opposite side	6630190	1
4	Pressure plate	6630106	2
5	Retaining Disc	See Note *	2
6	Spring clip	7901079	2
7	Keep plate	7950960	2
8	Pivot pin	8250058	2
9	Tension spring	2400140	2
10	Pad Assembly	See Table 4	2
11	M8 nut self locking	5100135	2
12	Mills pin	3150084	4
13	Circlip	4300135	4
14	Grease Nipple	1402417	4
15	'O' ring	6000204	4
16	'O' ring	6000448	4
17	M5 x 16 csk. skt. hd. screw	5500070	2
18	M8 x 45 hex. head bolt (GMR)	5000805	2
	M8 x 55 hex. head bolt (GMR40)	5000818	2

TABLE 4 – Friction Pad Assemblies

Part No.	Material	Colour Code	Remarks
7080080-R	Konoflex ISB-104	Green / White	
70A0080-AP	Saftek 75127	Yellow / Yellow / Yellow	
70A0080-AF	Saftek 75155	Yellow / Yellow / Red	Fire Resistant
7080080-Z	Saftek 75103	Green / Green / Red	
7080314-Z *	Saftek 75103	Green / Green / Red	Full Retaining Disc
7080080-8	TBL BF 6001	Green / Yellow	
7080080-W	TMD 544	Green / Green / Yellow	

* All Friction Pad Assemblies are used with Retaining Disc (Item 5 – Figure 2) 7950948 except Pad Assembly 7080314-Z which is used with Retaining Disc 7953478.

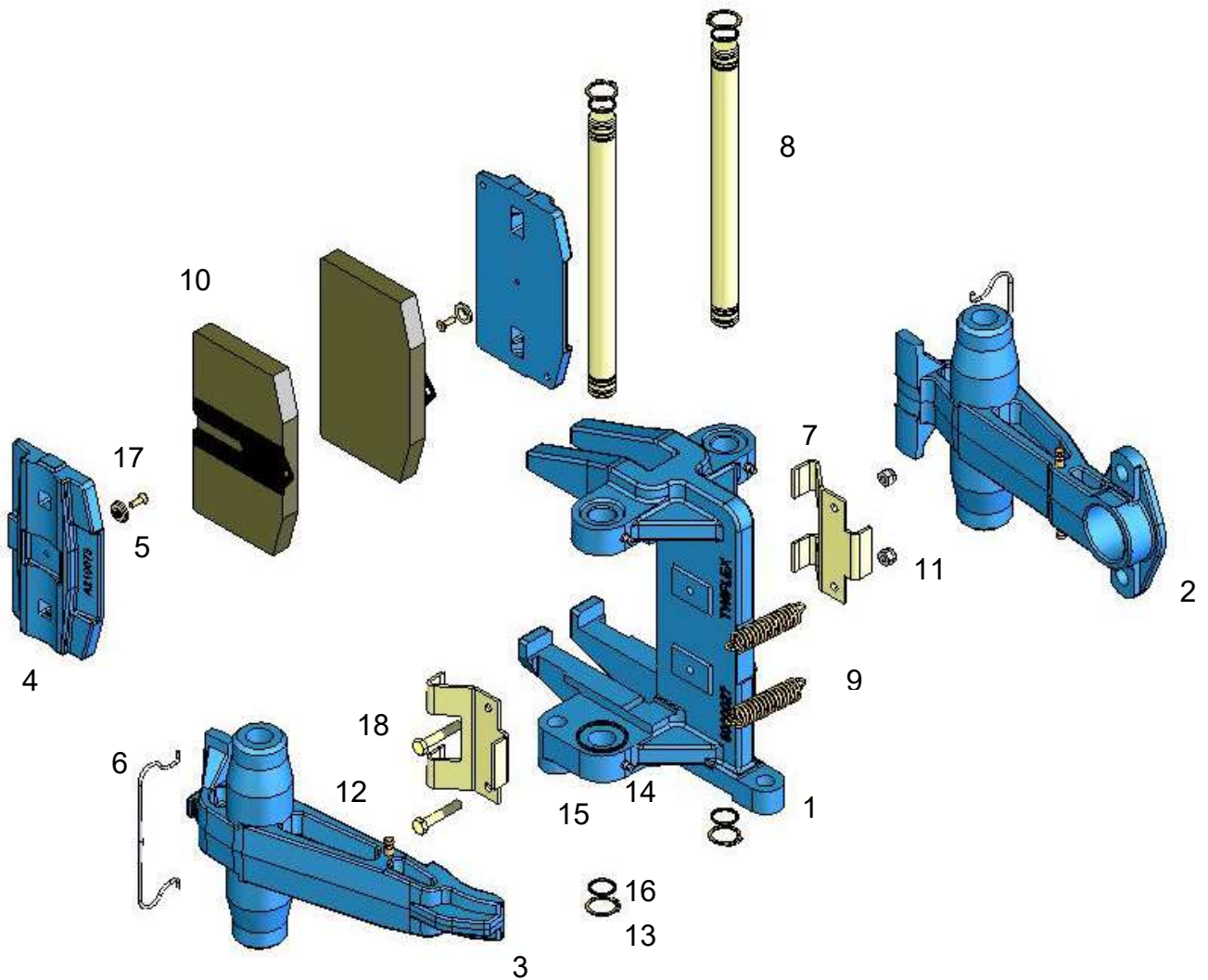

FIGURE 2 – GMR brake caliper: Basic Parts



1.2.2 SD THRUSTER (see Figure 3)

See Twiflex Drawing A11046

TABLE 5 – SD Thruster Basic Parts

Ref.	Description	Part No.	Qty
1	Front cap	7940984	1
2	Rear cap	7940991	1
3	Centre casing	7940995	1
4	Stud	8650004	2
5	M16 nut	5100239	2
6	M16 spring washer	5800008	2
7	Thrust collar *	1650464	1
8	Sleeve Assembly	7951062	1
9	Push Rod Assy.	7951212	1
10	Spacer	1650465	1
11	Adaptor Ring	1650466	1
12	Spring Plate	7951002	1
13	Pressure Plate	7951008	1
14	Support Plate	7951003	2
20	Diaphragm	7200776	2
24	Circlip - External	4300152	2
25	M8 x 40 Hex. Hd. Bolt	5000812	24
26	M8 Nut Nyloc 'T'	5100220	24
27	Plug 1/8 BSP	7300432	2
28	Washer 1/8 BSP	7300435	2
29	M16 x 200 Retraction Screw **	5350238	1
30	Red Cap	8300030	1
31	Red Cap 1/2" BSP	8300031	2
34	Bush Glacier	1800372	1
35	Bush Glacier	1800374	1

* Item 7, Thrust Collar (1650464) is not used when Monitor Unit 7701384, 7701394, 7701395 or 7701442 is fitted.
If Monitor Unit 7700263 is to be fitted then a different Thrust Collar (1650469) is supplied by Twiflex for transportation purposes. This can be easily removed to fit the Monitor Unit.

** Item 29, Retraction Screw (5350238) is changed for 5300377 (M16 x 250mm long Retraction Screw) if Monitor Unit 7701384, 7701394, 7701395 or 7701442 is used.

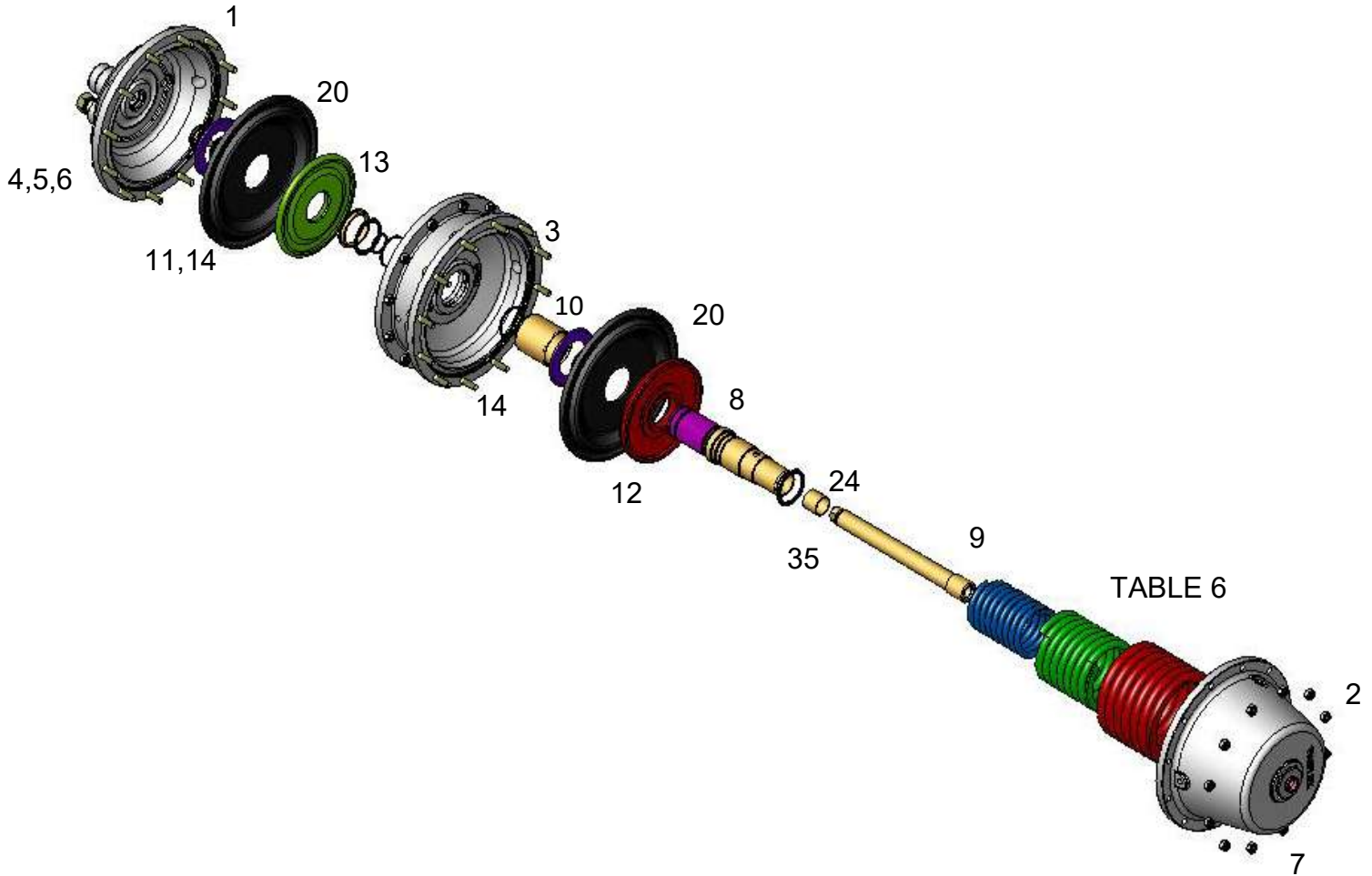

FIGURE 3 – SD Thruster: Basic Parts



TABLE 6 – Spring Pack

By removing or adding springs the thruster force can be altered

Thruster Type	Item No.	Spring Part No.
SD4.5	22	2500130
SD8.4	21	7200397
SD11	21	7200397
	23	2500131
SD12.9	21	7200397
	22	2500130
SD15.6	21	7200397
	22	2500130
	23	2500131

TABLE 7 – Seal Kit

Item No.	Description	Part No.	Qty.
15	Wiper Seal	6000242	1
16	Rod Seal	6000243	1
17	Slip-O-Ring	6000225	1
18	'O' Ring	6000138	1
19	'O' Ring	6000224	3



1.3 **Performance Data**

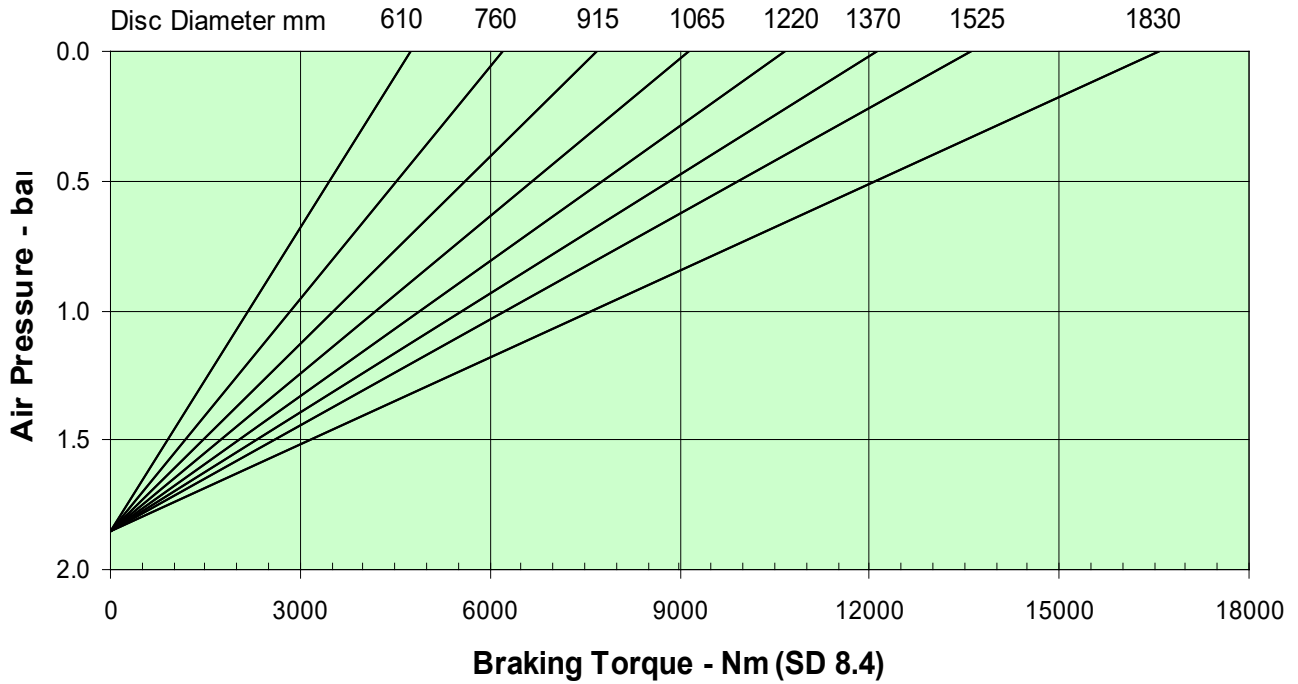

Braking Performance at 19.5 kN Braking Force

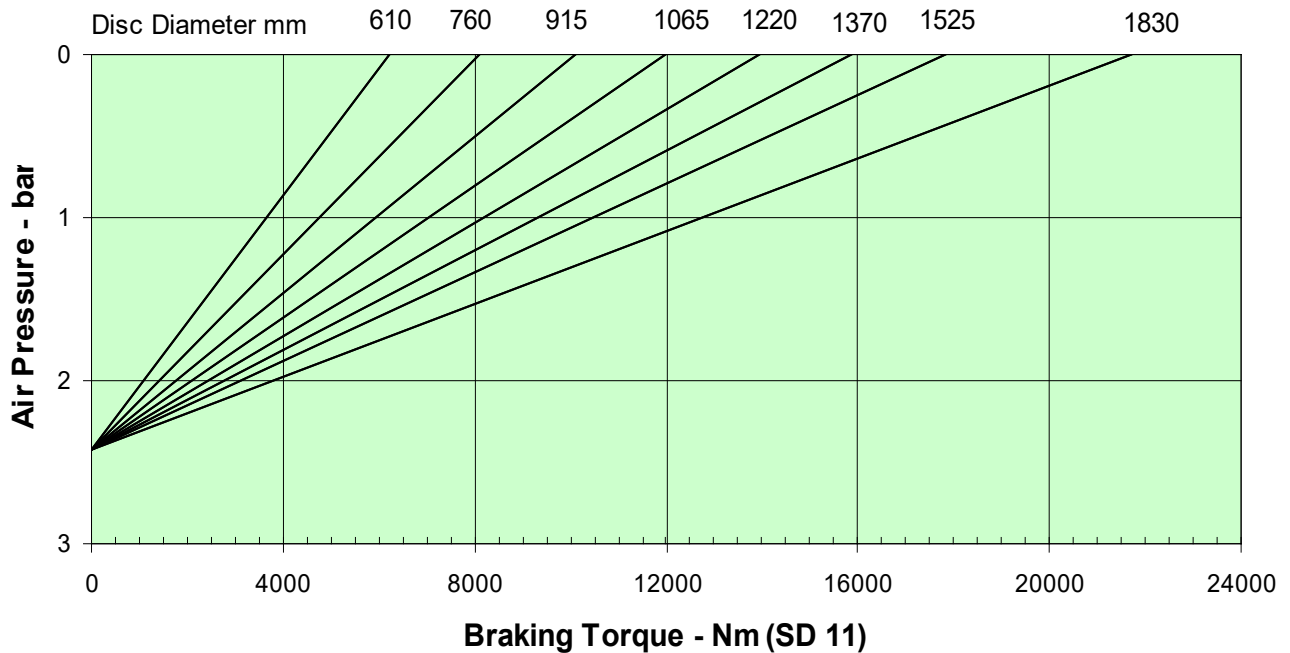

Braking Performance at 25 kN Braking Force

Note: Disc Diameter in mm

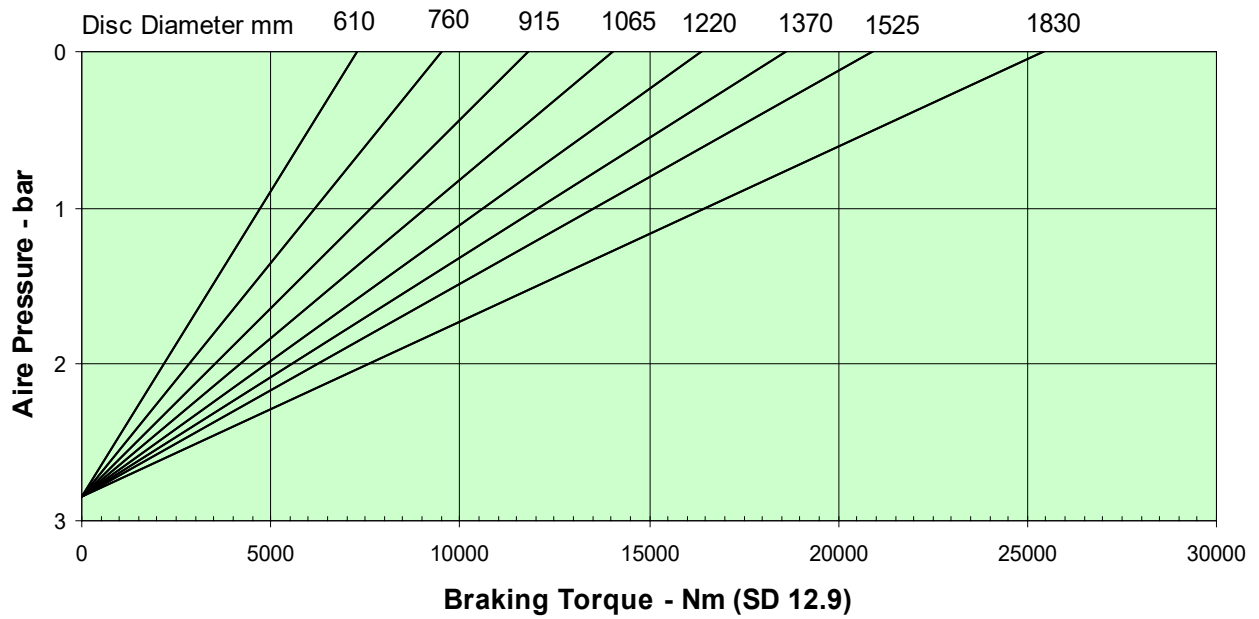

Braking Performance at 30 kN Braking Force

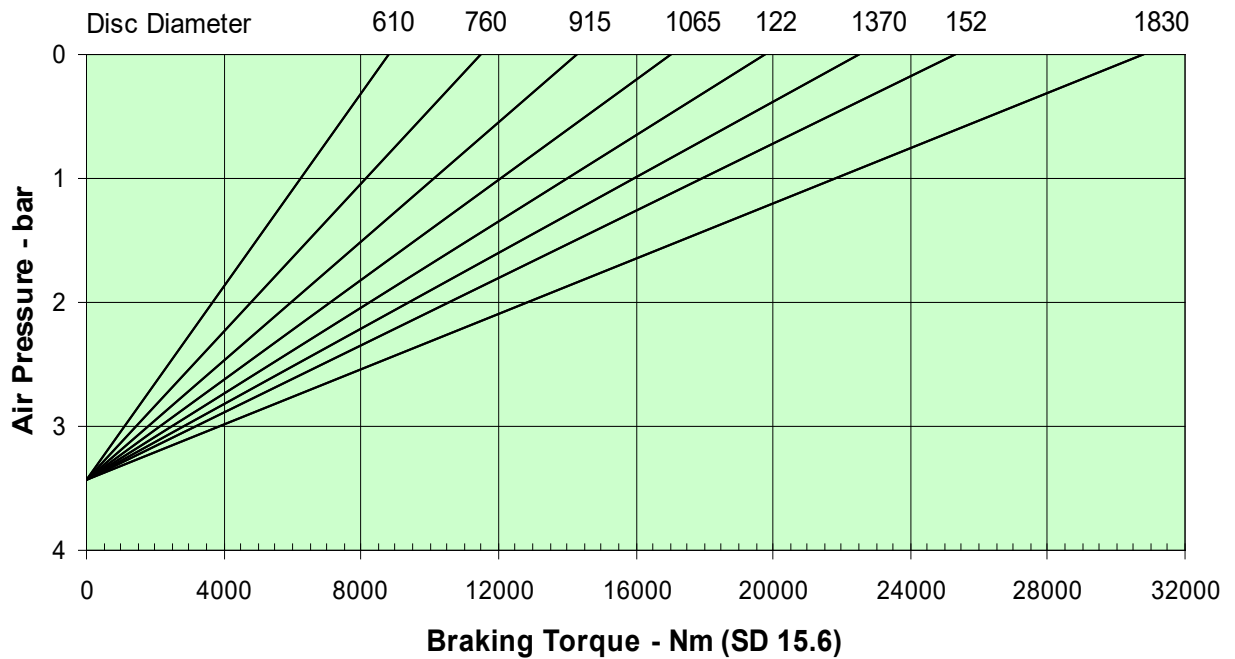

Braking Performance at 36 kN Braking Force

Note: Disc Diameter in mm



2. INSTALLATION

The GMR / GMR40 caliper and SD Thruster is normally supplied separately and need to be assembled as follows :-

2.1 Caliper Installation

2.1.1 The caliper must be mounted on a suitably rigid support, capable of absorbing braking forces of up to 36KN (3.6 ton). Three fixing bolts are required, M16 grade 8.8. The bolts should be tightened to a torque of 150Nm (110 lb.ft).

2.1.2 The caliper should be positioned symmetrically with respect to the disc, as shown on Twiflex drawings A01180 and A01221.

2.1.3 If the caliper is to be mounted on a surface inclined to the horizontal, then the caliper should be fitted with an inclined mounting kit. (see Para. 2.2)

2.1.4 Calipers are normally supplied assembled right handed, as shown on Twiflex drawings A01180 and A01221, unless otherwise specified.

2.2 Inclined Mounting Kit

Where the caliper is mounted at more than 10° from the horizontal (or on vertical shafts) it should be fitted with an inclined mounting kit (Twiflex Part No. 6700458). see Figure 4.

Figure 4 Ref.	Description	Part Number	Qty
1	Block	7951043	1
2	M6 x 30 hx. hd. Bolt	5000706	2
3	M6 spring washer	5000031	2
4	M10 x 50 hx. hd. setscrew	5300182	1
5	M10 Locknut	5200034	1
6	Grooved Pin	3150084	2
7	Bracket	7951042	2
8	M8 x 40 Hex. Hd. Bolt	5000812	2
9	Tension Spring	2400136	2

TABLE 8 – Inclined Mounting Kit

2.2.1 Fit block (1) using M6 bolts and washers (3) and spring pins (6) to GMR caliper body. The required holes are already drilled or tapped.

2.2.2 Fit M10 setscrew (4) and locknut (5) to block (1) to act as stop screw. The stop screw should be adjusted to maintain equal pad clearance on either side of the disc.

2.2.3 To fit brackets (7) to SD Thruster, retraction screw should be fitted to the thruster. Fit only one bracket at a time, using longer M8 cap screws (8) provided.

2.2.4 Place springs (9) between spring pin (6) and bracket (7).

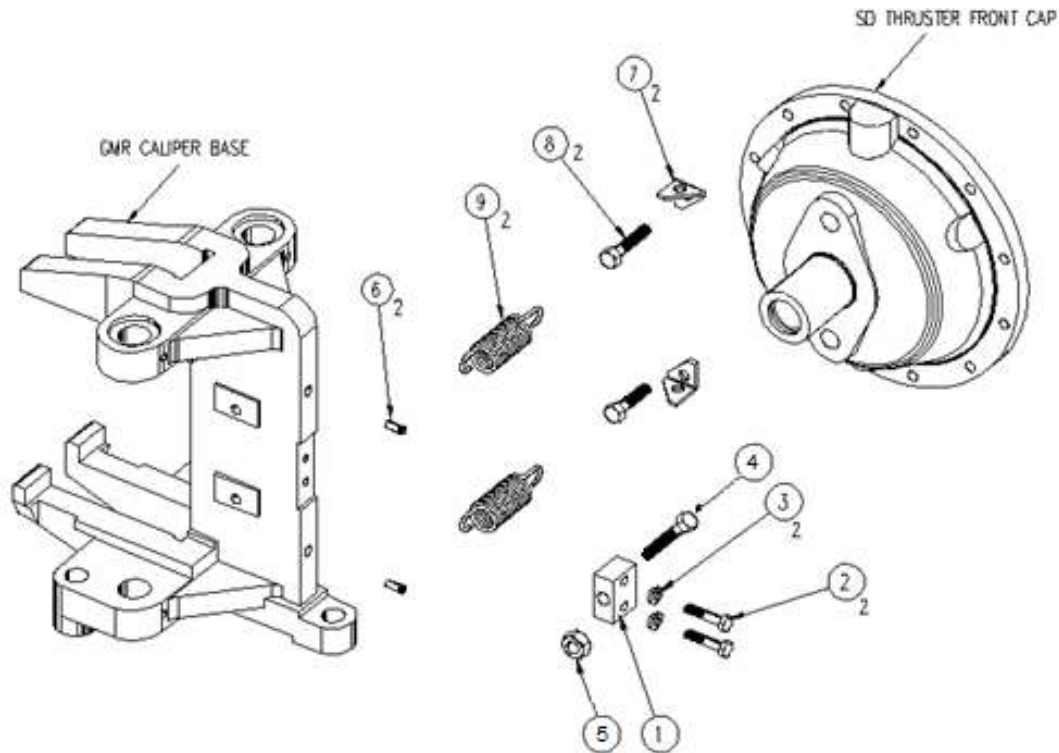

FIGURE 4 – Inclined Mounting Kit

2.3 Thruster Installation and Setting

2.3.1 The thruster is normally supplied separately from the caliper, and with the retraction screw fitted to hold it in the "off" position (see Para. 3.2) until it has been fitted on the caliper arm. Nuts and washers for this purpose are supplied and should be tightened to 45Nm (33 lb.ft) torque. (see Twiflex drg. A11046 Items 5 & 6). Thrusters are normally fitted with air inlets uppermost.

CAUTION
FAILURE TO OBSERVE THE 45Nm (33 lb.ft) TORQUE SETTING MAY LEAD TO THREAD DAMAGE WHICH COULD RESULT IN THE THRUSTER MOUNTING STUDS BEING FORCIBLY EJECTED DUE TO THE AIR PRESSURE.

2.3.2 The two air inlets on the thruster are tapped G1/2 (1/2"BSP). Both must be used. The air supply should be connected via a length of flexible piping to accommodate the movement during operation. A quick exhaust valve may be fitted if very rapid brake operation is required.



2.3.3 The brake is applied by the thruster springs and released pneumatically. The required air pressure for full retraction is dependent on the thruster type. see Tables 1 & 2. - Maximum allowable pressure is 5 bar.

CAUTION
**THE RETRACTION SCREW SHOULD BE REMOVED COMPLETELY
WHEN THE BRAKE IS IN SERVICE.**

2.3.4 The air supply used should be dry, oil free and filtered. Operation of the thruster at full stroke requires approximately 2.5 litres of compressed air.

2.3.5 The thruster stroke should be set at 20mm by unscrewing (outwards) the push rod. (Item 9 – Twiflex drg. A11046). See Figure 5.
Should the thruster stroke exceed 20mm due to pad wear, the braking force will be reduced unless adjustment is carried out. For each 10mm increase in thruster stroke the braking force is reduced by approximately 7%.

To make adjustments the brake must be off (i.e. air pressure on).

- (i) Pull the opposite side caliper arm away from the push rod and turn the rod as required; one turn gives 2mm adjustment (see Figure 5). Twiflex drg. A11046
- (ii) Release the caliper arm, ensuring the flats on the push rod are engaged in the slot in the caliper arm. (A 17mm A/F spanner will fit the flats on the push rod).

CAUTION
**KEEP FINGERS CLEAR OF THE SPACE BETWEEN PUSH ROD AND
CALIPER ARM AT ALL TIMES**

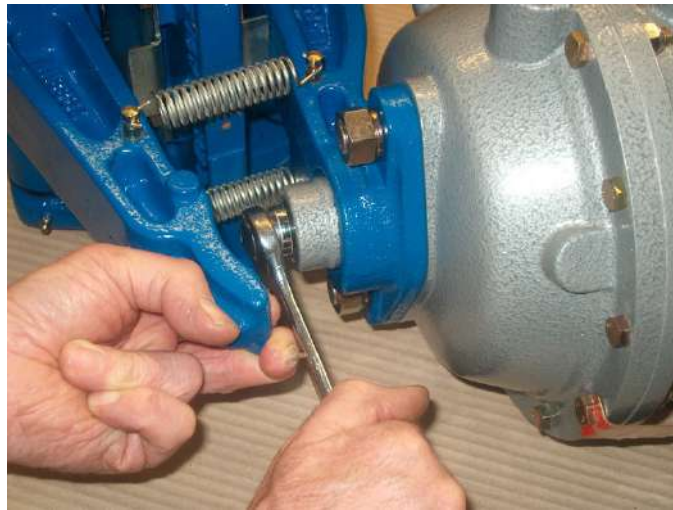

FIGURE 5 – Thruster Setting



2.4 Monitor Unit

The SD Thruster maybe supplied with a monitor unit (not fitted) which can be set to indicate full retraction and when adjustment is required due to pad wear.
Two types are available (see Para. 1.1.2) :-

- (i) Mechanical (microswitch) Type - Twiflex Part No. 7700263
Refer to Twiflex Drawings A11210 and A41021 for installation and set up.
- (ii) Electrical (proximity sensor) Type - Twiflex Part Nos. 7701384, 7701394, 7701395 and 7701442
Refer to Twiflex Drgs. A01601, A01674, A01684 for installation and set up *.

*** in order to fit Twiflex Part No. 7701384, 7701394, 7701395 or 7701442 the standard SD Thruster Rear Cap 7940991 needs to be replaced by Rear Cap X1968.**

2.5 Brake Pad Conditioning

Before the GMR-SD and GMR40-SD disc brake calipers are ready for use the friction pads need to be bedded-in.

2.5.1 The bedded-in procedure consists of two phases:

- (i) Firstly bedding the pads on the disc so that the full area of the pad is making contact and the disc itself is beginning to polish.
- (ii) Secondly the generation of progressively more heat at the pad surface to condition the material by chemical changes so caused until it is able to perform the maximum duty that will be asked of it.

2.5.2 The amount of bedding-in / conditioning that will be needed in any particular case will vary according to the initial condition of the material and the severity of the duty and the procedure may be shortened or lengthened by the commissioning engineer according to his observation of the performance of the pads during this period.

2.5.3 The principle is to work the brake lightly at first to remove high spots and so achieve something approaching 100% pad contact with the disc. This is best achieved by operating the brakes a few times with the disc running.
When complete, carry out any statutory or other testing that may be required.

2.5.4 If the brake is designed for severe emergency use, which might afterwards necessitate disc resurfacing and / or pad replacement, testing should be carried out at 50% or 75% full speed.



3. OPERATION

3.1 General

3.1.1 The GMR-SD and GMR40-SD disc brake calipers are spring applied, air released. Retraction pressures vary with the caliper rating / thruster spring setting as shown in Table 1 & 2 – see Para. 1.3, performance data.

Variable braking torque can be achieved by regulating the air pressure.

3.1.2 The thruster stroke should be maintained at 20mm by unscrewing the pushrod. (see Para. 2.3.5).

3.1.3 If an inclined mounting kit (see Para. 2.2) is fitted the stop screw should be readjusted to maintain equal pad clearance on either side of the disc.

3.2 Manual Retraction

3.2.1 Without Monitoring Unit Fitted

3.2.1.1 To enable the brake to be released in the event of air supply failure, an M16 x 200 long retraction screw (Figure 6) is supplied. This is inserted into the rear of the thruster and screws directly into the inner end of the pushrod. The retraction screw should be well lubricated and can also be used as the safety screw during maintenance.

3.2.1.2 **The retraction screw should be removed completely whilst the brake is in operation, and the red plastic cap – Twiflex drg. A11046: Item 30, fitted in the hole. The brake should be pressurised, i.e. off, when removing the retraction screw.**

CAUTION
**KEEP FINGERS CLEAR OF THE SPACE BETWEEN PUSH ROD
AND CALIPER ARM AT ALL TIMES**



**FIGURE 6 – Manual Retraction Screw
(screw shown partially fitted)**

3.2.2 With Monitoring Unit Fitted

If the SD Thruster is fitted with a Twiflex Monitoring Unit (Part No. 7700263) then this will need to be completely removed before the brake can be manually retracted. The procedure in Para 3.2.1 should then be followed.

If the SD Thruster is fitted with Twiflex Monitoring Unit (Part No. 7701384, 7701394, 7701395 or 7701442), then the following procedure should be used to manually retract the brake:

- 3.2.2.1 To enable the brake to be released in the event of air supply failure, an M16 x 250 long retraction screw is supplied – Twiflex drg. A01601.
- 3.2.2.2 Remove the plastic cap, insert the retraction screw and screw it fully into the inner end of the pushrod through the cover - see Figure 7
The retraction screw should be well lubricated and can also be used as the safety screw during maintenance.

**The retraction screw should be removed completely whilst the brake is in operation, and the red plastic cap fitted in the hole.
The brake should be pressurised, i.e. off, when removing the retraction screw.**



**FIGURE 7 – Monitor Unit Part No. 7701384, 7701394,
7701395 with Retraction Screw being fitted
(Thruster shown without spring pack)**



4. MAINTENANCE

4.1 Maintenance Schedule

4.1.1 Monthly Maintenance

- (i) The surface of the caliper arm, on which the thruster push rod bears, should be well greased (see Para. 4.2.3)
- (ii) Clean knuckle joints between the caliper arms and the pressure plates, and apply a small amount of grease; the joints may be levered apart slightly against the pressure of the spring clip.
- (iii) Inject a small amount of grease via grease nipples to lubricate the pivot pins, then rotate pins to distribute the grease. Any grease exuding past the 'O'-rings should be wiped off. The pins may be turned by gripping the knurled end at the top of the caliper.
- (iv) Clean the push rod. If the air supply is wet, the drain plug (Twiflex drg. A11046 – Item 27) should be removed at intervals to release any accumulated water.
- (v) Ensure that the brake pad and disc remain free from oil and grease.
- (vi) Clean the disc as required.
- (vii) Check for pad wear. If the pads become contaminated they should be replaced immediately. (see Para 4.2.1 - Pad Replacement).
- (viii) Check the thruster stroke is 20mm and if necessary adjust by unscrewing the pushrod. (see Para. 2.3.5).
- (ix) Inspect the tightening of thruster mounting screws and confirm the torque is 45Nm (33lbf-ft).

CAUTION

FAILURE TO OBSERVE THE 45Nm (33 lb.ft) TORQUE SETTING MAY LEAD TO THREAD DAMAGE WHICH COULD RESULT IN THE THRUSTER MOUNTING STUDS BEING FORCIBLY EJECTED DUE TO THE AIR PRESSURE.

4.1.2 Periodic Maintenance

At six monthly intervals the following should be carried out in addition to the monthly maintenance schedule outlined in Para. 4.1.1:

- (i) The caliper pivot pins (Item 10 – Figure 2) should be withdrawn, cleaned and re-greased or replaced if badly worn. (see Para. 4.2.2)

- (ii) Check the thruster push rod (Item 9 – Figure 3) for wear / damage and replace if necessary (see Para. 4.2.4).

4.2 Routine Maintenance

CALIPER

4.2.1 Pad Replacement

(for Item numbers refer Twiflex drg. A11046)

If the caliper assembly includes pads with a wear allowance / indicator groove machined in the edges then the pads must be replaced when the front edge of the groove is no longer visible.

If the pads are supplied without wear allowance / indicator grooves then the maximum allowable wear on each pad is 10mm. (see Para. 2.3.5)

- (i) Pad replacement is carried out from the rear of the caliper.

DO NOT RELEASE THE SPRING CLIPS (Item 6) THAT ATTACH THE PRESSURE PLATES (Item 4) TO THE CALIPER ARMS.

- (ii) With the brake off (retraction screw fitted as a safety screw – see Para.3.2) remove the return springs (Item 9) on the caliper arms and the keep plates (Item 7) as shown in Figures 8 and 9.
- (iii) Withdraw the pads (Item 10) to the rear and lift out as shown in Figure 10. (The hole in the end of the pad backing plate is provided to assist in withdrawing the pads).

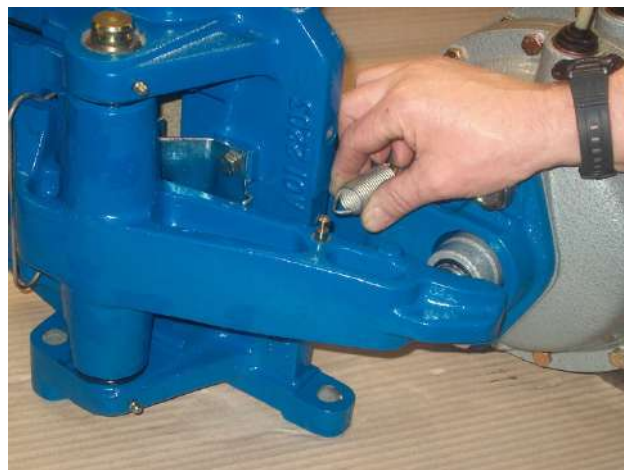

FIGURE 8 – Release Return Springs

- (iv) Fit the new pads ensuring that the slotted retaining plate is located around the pad retaining disc; the pads should slide freely into position.
- (v) Replace keep plates and return springs as in (ii).
- (vi) Re-adjust the thruster pushrod (see Para. 2.3.5).
- (vii) If an inclined mounting kit is fitted, re-adjust the stop screw to maintain equal pad clearance on either side of the disc (see Para 2.2)

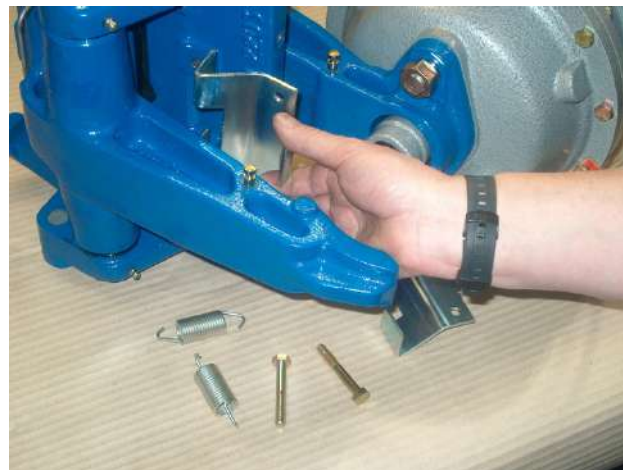

FIGURE 9 – Remove Keep Plates



FIGURE 10 – Replace Pads

4.2.2 Pivot Pin Replacement

If after extended use the pivot pins are badly worn then they should be replaced. This can only be achieved by dismantling the caliper from its mounting bracket. Care must be taken not to damage the 'O'-ring seals on the pins.

- (i) Remove the top circlip (Item 13).
- (ii) Push the pin down not more than 12mm for the lower circlip and 'O'-ring (Item 16) to be removed.
- (iii) Withdraw the pin upwards as shown in Figure 11.
- (iv) Refitting the pin is the reverse of this procedure, (i) to (iii).

4.2.3 Recommended Lubricants

Calipers: Medium grease containing Molybdenum disulphide
e.g. Castrol LMM; Shell Alvania 2 + MoS₂

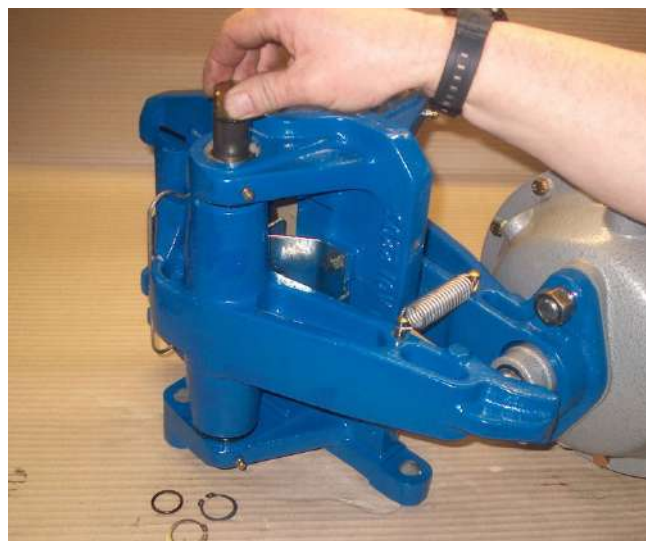

FIGURE 11 – Pivot Pin Replacement



THRUSTER

4.2.4 Push Rod Removal / Replacement

4.2.4.1 Without Monitoring Unit Fitted

(for Item numbers refer Twiflex drg. A11046)

- (i) If the push rod (Item 9) is damaged it must be replaced.
- (ii) With the brake off (pressurised), remove the plastic cap (Item 30), insert the retraction screw (see Para. 3.2) and screw it fully in; finger tight is sufficient. (If thruster will not retract, the brake should be released, using the retraction screw, which should be well lubricated). Disconnect the air supply and remove the thruster from the caliper.
- (iii) Remove the retraction screw so that the thruster operates through its full stroke with the spring load supported on the front cap.
The use of a temporary air supply will be found convenient, as it avoids having to turn the retraction screw under load
- (iv) Remove the thrust collar (Item 7) from the rear cap (Item 2).
- (v) Unscrew the push rod until it can be withdrawn through the rear of the thruster (Figure 12). Clean and examine the push rod, replace if damaged. Clean other parts.
- (vi) Re-lubricate the front cap bearing, the internal thread of the sleeve (Item 8 – Figure 3) the rear cap bore adjacent to the end of the sleeve, and the threads (internal and external) of the push rod, with grease.
- (vii) Re-fit the push rod into the thruster and replace the thrust collar. Use Loctite 601 (Retainer) on the Thrust Collar if loose.
- (viii) Pressurise the thruster, check for leaks and fit the retraction screw.
- (ix) Re-fit the thruster to the caliper (see Para. 2.3).
- (x) Remove the retraction screw and replace the plastic end cap.

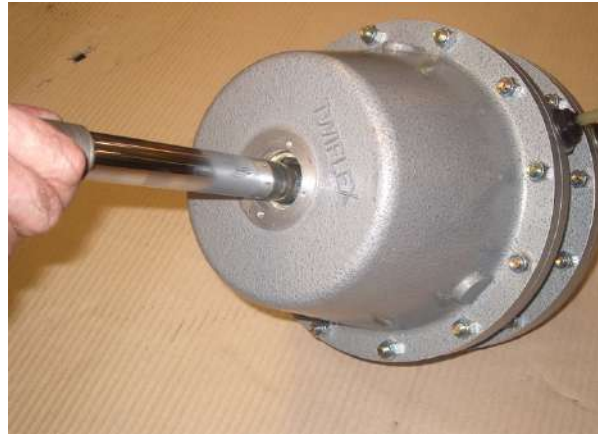

FIGURE 12 – Push Rod Removal

4.2.4.2 With Monitoring Unit Fitted

If the SD Thruster is fitted with a Twiflex Monitoring Unit (Part No. 7700263) then this will need to be completely removed before the Push Rod can be replaced - Twiflex drg. A11210

The procedure in Para 4.2.4.1 should then be followed.

If the SD Thruster is fitted with Twiflex Monitoring Unit (Part No. 7701384, 7701394, 7701395 or 7701442) – Twiflex drgs. A11046, A01601, A01674 and A01684 then the following steps should be used to replace the Push Rod:

- (i) Follow procedure in Para. 4.2.4.1 (i) to (iii).
- (ii) Remove the Monitoring Unit Cover and take out the Striker. This may require a small amount of force to free the Striker from the Sleeve (Item 8 – Twiflex drg. A11046) which is bonded to the latter using Loctite 641 (Bearing Fit). Clean the Sleeve bore.
- (iii) Unscrew the push rod until it can be withdrawn from the rear of the Thruster, then extract the push rod through the Monitor Unit Retraction Housing.
Clean and examine the push rod, replace if damaged.
Clean other parts.
- (iv) Re-lubricate the front cap bearing, the internal thread of the sleeve, the rear cap bore adjacent to the end of the sleeve, and the threads (internal and external) of the push rod, with grease.



- (v) Re-fit the push rod into the thruster and replace the Striker making sure it is fitted into the Sleeve using Loctite 641 (Bearing Fit).
- (vi) Re-fit the Monitoring Unit Cover
- (vii) Pressurise the thruster, check for leaks and refit the retraction screw (see Para. 3.2.2).
- (viii) Re-fit the thruster to the caliper (see Para. 2.3).
- (ix) Remove the retraction screw and replace the plastic cap.

4.2.5 Stripdown and Seal Replacement

In the event of leakage or malfunction of the thruster, the following parts can be inspected and replaced if necessary without decompressing the spring pack:
Item numbers in accordance with Twiflex drg. A11046 and Figure 3.

Item No.	Part	Item No.	Part
20	Diaphragm	17	Slip 'O' Ring
16	Rod Seal	10	Spacer
34	Bearing	9	Push Rod
15	Wiper Seal		

NOTE:

Replacement of any other components, e.g. O-ring (Item 19) under spring plate, O-ring (Item 18), bush (Item 35) require the spring pack to be decompressed. (see Para. 4.3.1)

Thruster stripdown and seal replacement is carried out as follows:

4.2.5.1 Without Monitoring Unit Fitted

Item numbers in accordance with Twiflex drg. A11046 and Figure 3.

- (i) With the brake off, remove the plastic cap (Item 30), insert the retraction screw (see Para. 3.2) and screw it fully in; finger tight is sufficient. (If thruster will not retract, the brake should be released, using the retraction screw, which should be well lubricated). Disconnect the air supply and remove the thruster from the caliper.
- (ii) Adjust the retraction screw to allow a thruster stroke of approximately 32mm (i.e. just under full stroke). This adjustment allows the diaphragm to assume its natural shape which eases re-assembly.
The use of a temporary air supply will be found convenient, as it avoids having to turn the retraction screw under load.



- (iii) Withdraw the bolts securing the front cap (Item 1). Remove the front cap, circlip (Item 24), adapter ring (Item 11), support plate (Item 14), front diaphragm (Item 20) and pressure plate (Item 13). The 'O' ring (Item 19) which seals the pressure plate bore should also be removed and discarded if damaged.



FIGURE 13 – Front Cap removed

- (iv) Withdraw the bolts securing the centre casing (Item 3) to the rear cap. Remove the centre casing, support plate (Item 14) and rear diaphragm (Item 20). The diaphragms should be free from splits or cracks, but some wear from the edges of the pressure plate or spring plate are acceptable if the fabric reinforcement is not damaged.



**FIGURE 14 – Centre Casing removed
(rear diaphragm removed)**



- (v) Leakage of air past the rod seal (Item 16) or the slip o-ring seal (Item 17) may be caused by damage to the seals, the pushrod (Item 9) or the spacer (Item 10). The surfaces of the pushrod and spacer must be smooth and free from scoring or bruising.
Note: the pushrod cannot be removed whilst the thruster is dismantled (see Para. 4.2.4).
- (vi) The rod seal (Item 16) comprising two parts, (a P.T.F.E sealing ring and an 'O' ring) may be removed using a small screwdriver or similar tool taking care not to damage the groove. Once removed the seal should not be re-used. When fitting a new rod seal the P.T.F.E. ring must be compressed, which requires the use of a fitting tool – Twiflex drg. A21123
Note: the stepped side of the ring is the pressure side.
- (vii) The slip o-ring seal (Item 17), which is fitted in the centre casing, can easily be examined in situ. It is of a similar design to the rod seal, but the P.T.F.E. sealing ring is thinner and can be fitted without special tools by carefully deforming the ring, whilst avoiding sharp bends.
- (viii) The wiper seal (Item 15) serves both to retain grease and to exclude dirt from the bush (Item 34). The section of the pushrod which moves through the wiper seal, should be cleaned with a very light lubricant film. The wiper seal is of all rubber construction and is easily replaced without tools.
- (ix) The bush (Item 34), which is pressed into the front cap, has a number of shallow circular indentations in its surface, which retains grease. The acceptable wear limit is 0.2mm, approximately half the depth of the indentations in a new bearing. A worn bearing can be withdrawn (after removal of the wiper seal which may be re-used if undamaged) using a suitable extractor. The new bearing should be pressed in until flush with the base of the wiper seal recess.
- (x) Assembly of the thruster is the reverse of the dismantling procedure.
Note: the spacer (Item 10) should be fitted before the centre casing (Item 3). 'O' rings and seals should be lightly greased to ease assembly. The grease reservoir groove in the front cap and bearing indentations should be filled with grease. Use a good quality silicone or mineral based medium grease. (see Para. 4.2.6).
- (xi) Ensure that the beaded edges of the diaphragms locate correctly in the grooves, and tighten the bolts (Item 25) to 25 Nm (18 lb ft.), progressively until flanges are 100% in contact.
- (xii) After re-assembly, pressurise the thruster and check for leaks. Fit the retraction screw to maintain full retraction and refit the thruster to the caliper. (After removing the retraction screw, replace the red plastic cap).
Note: Ensure the thruster is pressurised when removing the retraction screw.



4.2.5.2 With Monitoring Unit Fitted

If the SD Thruster is fitted with a Twiflex Monitoring Unit (Part No. 7700263) then this will need to be completely removed before thruster stripdown and seal replacement can be carried out.

The procedure in Para 4.2.5.1 should then be followed.

If the SD Thruster is fitted with Twiflex Monitoring Unit (Part No. 7701384, 7701394, 7701395 or 7701442) then seal replacement can be carried out without having to remove the unit.

In this instance the M16 x 250mm retraction screw supplied should be used in place of the shorter 200mm retraction screw and the procedure in Para. 4.2.5.1 is then followed.

4.2.6 Recommended Lubricants

Thrusters: Medium lithium based grease with rust inhibitors.
e.g. Duckham's Keenomax L2; Castrol AP 2; Shell Alvania R2

4.3 Major Service

In order to carry out a major service a hydraulic press (Figure 15) with the following specification is required:

- (i) Minimum Capacity 2 Tons
- (ii) Base Plate with:
Centre Hole 58mm diameter (2.25" diameter)
Minimum Diameter 152mm (6")
Maximum Diameter 250mm (10")
- (iii) Minimum Stroke 180mm (7")
- (iv) Clear Space between base plate and ram 710mm (28") with ram withdrawn.
- (v) Clear Space below base plate 250mm (10") minimum



FIGURE 15 – Hydraulic Press with SD Thruster mounted

In addition to the hydraulic press the following special tools are required:

- (vi) Assembly Compression Tool – Twiflex Part No. 7901846 (Drg. A21160)
- (vii) Assembly Guide Tool – Twiflex Drg. A32151



FIGURE 16 –Assembly Compression and Guide Tool

Special Tools are required for use with Twiflex Monitor Unit 7701384, 7701394, 7701395 and 7701442. Consult Twiflex for Part Numbers.

4.3.1 **Removal of the Spring Pack** (for Item numbers refer Twiflex drg. A11046)

If the SD Thruster is fitted with a Twiflex Monitoring Unit (Part No. 7700263) then this will need to be completely removed before a major service can take place. The procedure in Para. 4.3.1.1 is then followed.

In the event of an SD Thruster being fitted with Twiflex Monitoring Unit (Part No. 7701384, 7701394, 7701395 and 7701442), then the major service should be carried out in accordance with Para. 4.3.1.2.

4.3.1.1 Without Monitoring Unit Fitted (see Figures 16, 17 and 18)

- (i) With the brake off (pressurised), remove the plastic cap (Item 30), insert the retraction screw (see Para. 3.2) and screw it fully in; finger tight is sufficient. (If the thruster will not retract, the brake should be released, using the retraction screw, which should be well lubricated). Disconnect the air supply and remove the thruster from the caliper.



- (ii) Pressurise the brake (brake off) and insert the retraction screw and screw it fully in (finger tight is sufficient).
The use of a temporary air supply will be found convenient, as it avoids having to turn the retraction screw under load.
- (iii) Follow the procedure in Para. 4.2.5.1 (iii) to (iv)
- (iv) The following parts will remain on assembly, restrained by the retraction screw, which must not be removed at this stage: -
 - Springs (Items 21,22,23) as fitted.
 - Rear Cap (Item 2), with thrust collar (Item 7) and bush (Item 35)
 - Sleeve (Item 8)
 - Spring Plate (Item 12)
 - Push Rod (Item 9)
 - 'O' Rings (Item 18 and 19).
 - Circlip (Item 24)
- (v) This assembly should be placed in the press (rear cap uppermost) with the compression tool, (see Figure 17).
The circular end of the Compression Tool (Twiflex Part No. 7901846) must be placed concentrically on the rear cap as shown. The press ram should bear on the centre of the bridge piece. The minimum capacity for the press should be 2 tons.
- (vi) Operate the press until the retraction screw is free of load; do not use more force than necessary (1800kp (4000lb.f.) with 3 springs fitted).
Remove the retraction screw (see Figure 18).
- (v) Allow the press ram to retract slowly until the springs are fully decompressed approximately 170mm (6.75") stroke. Remove the parts from the press.
Remove the thrust collar (Item 7) from the rear cap (Item 2) by tapping out with a drift.

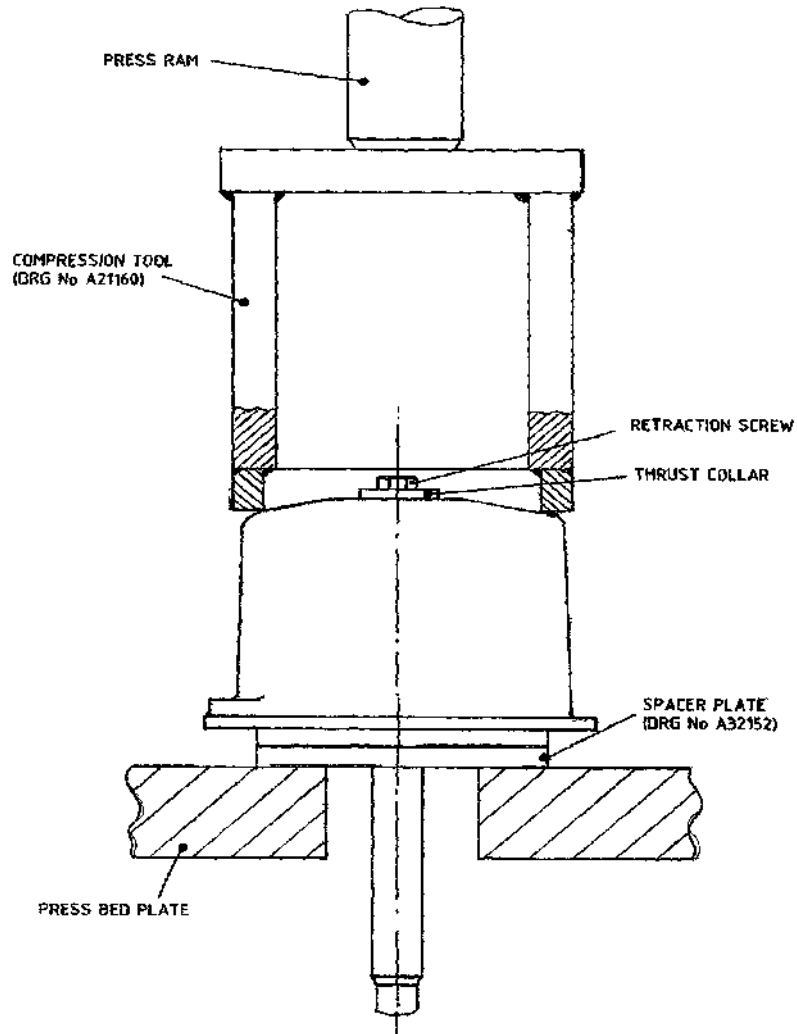

FIGURE 17 – Equipment Layout



FIGURE 18 – Retraction Screw removal



4.3.1.2 With Monitoring Unit Fitted

(refer Twiflex drgs. A11046, A01601, A01674 and A01684)

- (i) With the brake off (pressurised), remove the plastic cap, insert the M16 x 250mm Retraction Screw supplied (see Para. 3.2.2) and screw it fully in; finger tight is sufficient. (If the thruster will not retract, the brake should be released, using the retraction screw, which should be well lubricated). Disconnect the air supply and remove the thruster from the caliper.
- (ii) Remove the retraction screw so that the thruster operates through its full stroke with the spring load supported on the front cap.
The use of a temporary air supply will be found convenient, as it avoids having to turn the retraction screw under load.
- (ii) Remove the Monitoring Unit Cover (Figure 19) and take out the Striker. This may require a small amount of force to free the Striker from the Sleeve which is bonded to the latter using Loctite 641 (Bearing Fit). Clean the Sleeve bore.
- (iv) In place of the Monitor Unit Cover, fit a dummy cover or steel plate 12mm thick with a 17mm diameter centre hole to suit the retraction screw.
- (v) Pressurise the brake (brake off) and insert the retraction screw and screw it fully in; finger tight is sufficient.
- (vi) Follow the procedure in Para. 4.3.1.1 (iii) to (vii).



**FIGURE 19 – Monitor Unit Cover Removal
Thruster shown without spring pack fitted**

4.3.2 Assembly of the Spring Pack

The assembly procedure assumes that neither Twiflex Monitoring Units, Part Nos. 7700263 or 7701384, 7701394, 7701395 and 7701442 are fitted and the Thrust Collar (Item 7 – Twiflex drg. A11046) has been removed.

Note: If necessary the Retraction Housing for Monitor Unit, Part No. 7701384, 7701394, 7701395 or 7701442, may be fitted prior to assembly but the longer Assembly Guide Tool will need to be used.

Consult Twiflex for tooling part numbers.

The assembly procedure is as follows (for Item numbers see Twiflex drg. A11046):

- (i) Fit the following parts to the Sleeve (Item 8) :-
‘O’ rings (Items 18,19),
Spring Plate (Item 12)
Circlip (Item 24)
Note: the ‘O’ rings should be greased before assembly.
- (ii) Screw the pushrod (Item 9) with the threads well greased into the sleeve assembly until the thread is fully engaged. see Para 4.2.4
- (iii) Place the Sleeve Assembly on the base of the press with the Pushrod (Item 9) extending down through the central hole.
- (iv) Fit the Assembly Guide Tool (Twiflex drg. A32151). see Figure 20

Note: for SD Thruster fitted with Monitor Unit, Part Nos. 7701384, 7701394, 7701395 and 7701442 use the longer Assembly Guide Tool.

Consult Twiflex for tooling part numbers.



FIGURE 20 – Assembly Guide Tool

- (v) Assemble the springs as required onto the Spring Plate (Item 12) and place the Rear Cap (Item 2) onto the assembly. The Rear Cap will be located by the Assembly Guide Tool which fits into the Rear Cap Bush (Item 35). Ensure that the springs (which should be greased before assembly) are correctly located on the Spring Plate and in the Rear Cap.
- (vi) Using the Assembly Compression Tool (Twiflex Part No. 7901846 (Drg. A21160) compress the spring pack until dimension 'X' (see Figure 21) is reduced to approximately 25mm (1").

Note: for SD Thruster fitted with Monitor Unit, Part Nos. 7701384, 7701394, 7701395 and 7701442 use Assembly Compression Tool.

Consult Twiflex for tooling part numbers.

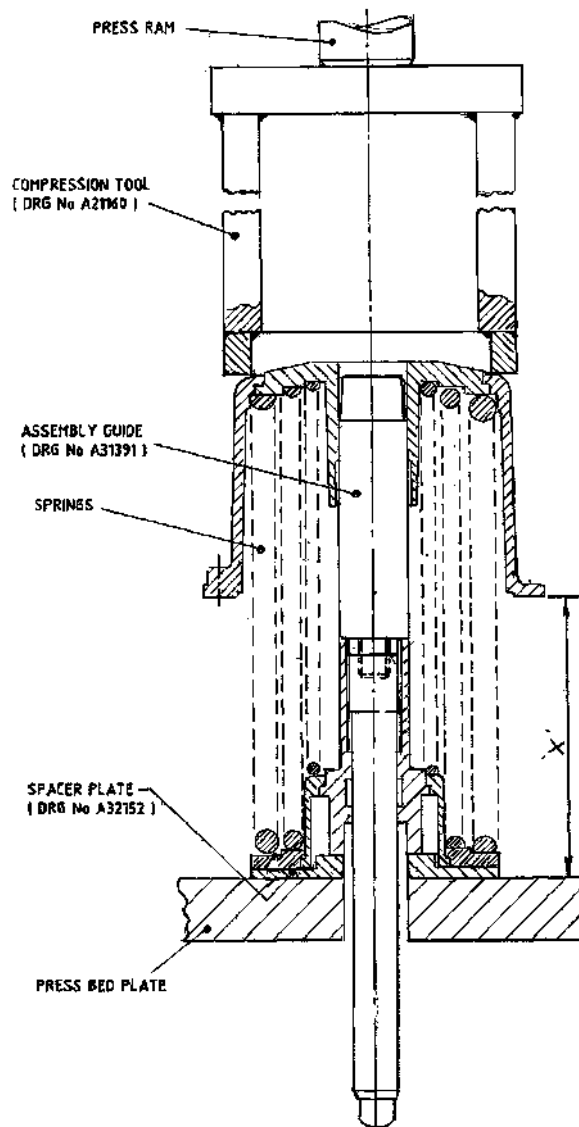

FIGURE 21 – Assembly Equipment Layout



For Thrusters without a monitoring unit fitted: (Refer Twiflex drg. A11046)

- (vii) Remove the Assembly Guide Tool and place the Thrust Collar (Item 7) * in position on the Rear Cap. The Collar should be a light press fit in the Cap, but provided that it is seated squarely (a lead chamfer is provided there is no need to hammer it in.
If loose use Loctite 601 (Retainer).
- (viii) Screw in the M16 x 200mm Retraction Screw until the head is in contact with the Thrust Collar. (prevent the pushrod from turning while fitting the retraction screw).
- (ix) Allow the press ram to retract slowly. The Thrust Collar will be drawn into position by the head of the Retraction Screw as the spring load bears on it.
- (x) Fully retract the press ram.
- (xi) Remove parts from the press and complete re-assembly of the Thruster in accordance with Para. 4.2.5.1 (x).

* If Twiflex Monitor Unit Part No. 7700263 is to be fitted then the Thrust Collar is not required.
Installation of Monitor Unit Part No. 7700263 is in accordance with Para 2.4 and Twiflex drg. A11210.

For Thrusters with a monitoring unit fitted:

(Part Nos. 7701384, 7701394, 7701395 and 7701442)

(assumes the Retraction Housing is already assembled to the Rear Cap).

- (vii) Remove the long Assembly Guide and fit a dummy cover in place of the Monitor Unit Cover (see Para 4.3.1.2 iv) to suit the M16 x 250mm Retraction Screw supplied.
- (viii) Screw in the Retraction Screw until the head is in contact with the dummy cover. (prevent the pushrod from turning while fitting the retraction screw).
- (ix) Fully retract the press ram.
- (x) Remove parts from the press and complete re-assembly of the Thruster in accordance with Para. 4.2.5.1.
- (xi) When the Thruster has been fully assembled it can be pressurised and the dummy cover removed. The Monitor Unit (Part Nos. 7701384, 7701394, 7701395 or 7701442) is installed in accordance Para. 2.4 and Twiflex drgs. A01601, A01674, A01684.



5. RECOMMENDED SPARES

5.1 GMR CALIPER (Figure 22)

Item	Description	Part Number	Qty
4	Pressure plate	6630106	2
5	Retaining Disc	7950948	2
	Retaining Disc	7953478 *	2
6	Spring clip	7901079	2
7	Keep plate	7950960	2
8	Pivot Pin	8250058	2
9	Tension spring	2400140	2
11	M8 nut self locking	5100135	4
12	Mills pin	3150084	4
13	Circlip	4300135	4
15	'O' ring	6000204	4
16	'O' ring	6000448	4
17	M5 x 16 csk. skt. hd. screw	5500070	2
18	M8 x 45 hex. head bolt (GMR)	5000805	4
	M8 x 55 hex. head bolt (GMR40)	5000818	4

Quantities are per Caliper Assy.

* Retaining Disc used with Pad Assy. 7080314-Z only

5.2 FRICTION PAD ASSEMBLY (Figure 22)

Part No.	Material	Colour Code	Remarks
7080080-R	Konoflex ISB-104	Green / White	
70A0080-AP	Saftek 75127	Yellow / Yellow / Yellow	
70A0080-AF	Saftek 75155	Yellow / Yellow / Red	Fire Resistant
7080080-Z	Saftek 75103	Green / Green / Red	
7080314-Z *	Saftek 75103	Green / Green / Red	Full Retaining Disc
7080080-8	TBL BF 6001	Green / Yellow	
70F0080-Y	DVRH 10442		Graphite
70F0080-AJ	DVRH 10442	Red / Blue	Graphite



FIGURE 22 – GMR Caliper Recommended Spares



5.3 SD THRUSTER (Figure 23)

Ref.	Description	Part No.	Qty
4	Stud	8650004	2
5	M16 nut	5100239	2
6	M16 spring washer	5800008	2
7	Thrust collar *	1650464	1
9	Push Rod Assy.	7951212	1
20	Diaphragm	7200776	2
24	Circlip - External	4300152	2
25	M8 x 40 Hex. Hd. Bolt	5000812	24
26	M8 Nut Nyloc 'T'	5100220	24
27	Plug 1/8 BSP	7300432	2
28	Washer 1/8 BSP	7300435	2
29	M16 x 200 Retraction Screw *	5350238	1
	M16 x 250 Retraction Screw **	5350377	1
30	Red Cap	8300030	1
31	Red Cap 1/2" BSP	8300031	2
34	Bush Glacier	1800372	1
35	Bush Glacier	1800374	1

Quantities are per Caliper Assy

* not used when Monitor Unit 7701384 or 7701394 is fitted

** used when Monitor Unit 7701384 or 7701394 is fitted

5.4 SPRING PACK (Figure 23)

Thruster Type	Item No.	Spring Part No.
SD4.5	22	2500130
SD8.4	21	7200397
SD11	21	7200397
	23	2500131
SD12.9	21	7200397
	22	2500130
SD15.6	21	7200397
	22	2500130
	23	2500131



5.5 SEAL KIT (Figure 23)

Item No.	Description	Part No.	Qty.
15	Wiper Seal	6000242	1
16	Rod Seal	6000243	1
17	Slip-O-Ring	6000225	1
18	'O' Ring	6000138	1
19	'O' Ring	6000224	3

Quantities are per Caliper Assy



FIGURE 23 – SD Thruster recommended spares