

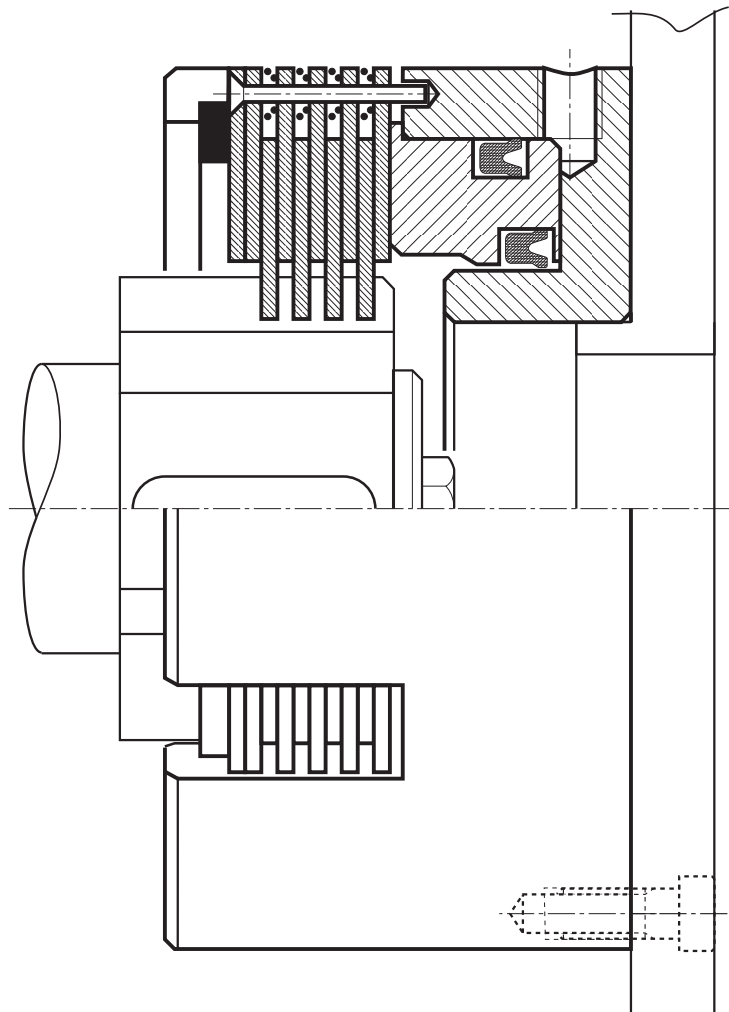

## **FRENO NEUMÁTICO MULTIDISCO DIRECTO**

# **FPL/BF**





# FRENO NEUMÁTICO MULTIDISCO DIRECTO FPL/BF

## FRENOS NEUMÁTICOS MULTIDISCO FPL/BF

Frenos fuertes y confiables, estos frenos son perfectos para aquellas aplicaciones en las que se requiere potencia y precisión en el frenado.

Su diseño simple incluye un paquete de discos, una carcasa de copa y un pistón que en conjunto forman el actuador neumático fijo.

El aire bajo presión ingresa a través del orificio externo «A», una solución que permite la eliminación de canales complicados y permite montar varios frenos en el mismo eje.

Una serie de muelles de separación de disco genera suficiente presión axial para permitir el rápido retorno de los pistones a su posición neutral, impactando mínimamente sobre el empuje de trabajo.

Para obtener el par de frenado nominal, debe garantizar los valores de presión de trabajo sugeridos en este catálogo.

También sugerimos que se instale la válvula de mando, que debe estar equipada con un dispositivo de descarga directa, lo más cerca posible del cilindro de trabajo, para desenganchar el freno de manera rápida y precisa.

## PNEUMATICALLY APPLIED MULTI-DISK BRAKES FPL/BF

Strong and reliable, these brakes are perfect for those applications where power and precision in braking are required.

Their simple design includes a disk pack, a cup housing and a piston which together form the fixed pneumatic actuator.

Air under pressure enters through external bore «A», a solution which permits the elimination of complicated channeling and allows several brakes to be mounted on the same shaft.

A series of disk separating springs, generates sufficient axial pressure to allow the quick return of the piston to its neutral position, impacting minimally on the working thrust.

Piston stroke and the thrust springs allow disk-wear take-up, thus eliminating the need of adjustment. Furthermore, mounting of the springs between the disks prevents most of the dragging when the brake is in the neutral position, allowing its installation in a vertical position (in the presence of very sensitive kinematic or where greater uncoupling precision is required).

For dry applications, this series of multi-disc brakes makes use of a combination of bronze/steel disks that actually allows you to work without lubrication.

To obtain the nominal brake torque, you must guarantee the working pressure value suggested on this catalogue. We also suggest to mount the command valve, which must be equipped with a blow-off device, as close as possible to the working cylinder, to quickly and precisely disengage the brake.



# FRENO NEUMÁTICO MULTIDISCO DIRECTO FPL/BF

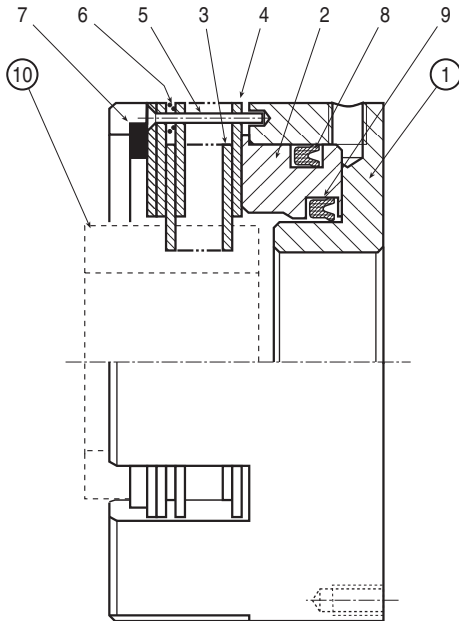

## PARTS LIST

1. CUP HOUSING
2. PISTON
3. INNER DISK
4. OUTER DISK
5. SPRING GUIDE PIN
6. DISK SEPARATING SPRING
7. INSIDE SAFETY RING
8. OUTER SEAL RING
9. INNER SEAL RING
10. HUB (ON DEMAND)

## MONTAJE

Estos frenos deben montarse bloqueando su cuerpo externo al de la máquina para que pueda fijar otro soporte con tornillos; posteriormente, debe montar el cubo fresado (bajo demanda) en el eje rotativo. El cubo va insertado en las aletas de los discos interiores (ver ejemplos de montaje).

## EJEMPLO DE MONTAJE

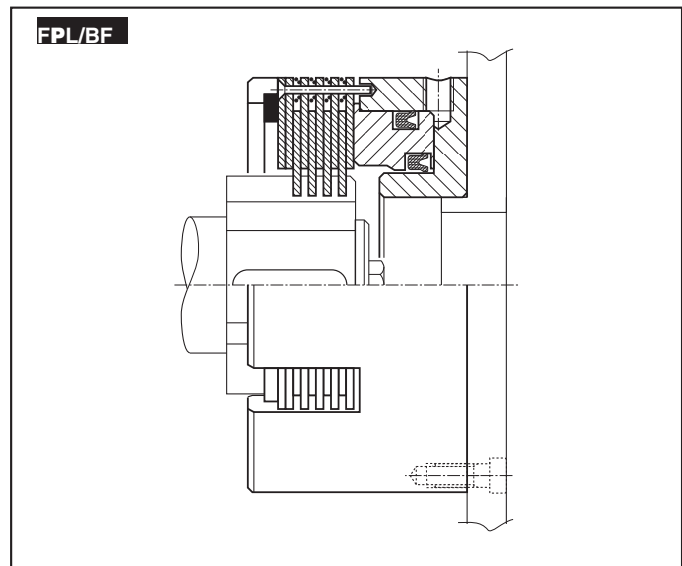



# FRENO NEUMÁTICO MULTIDISCO DIRECTO FPL/BF

MODEL  
CODE

FPL □□□/BF  
03.05.□□□.01

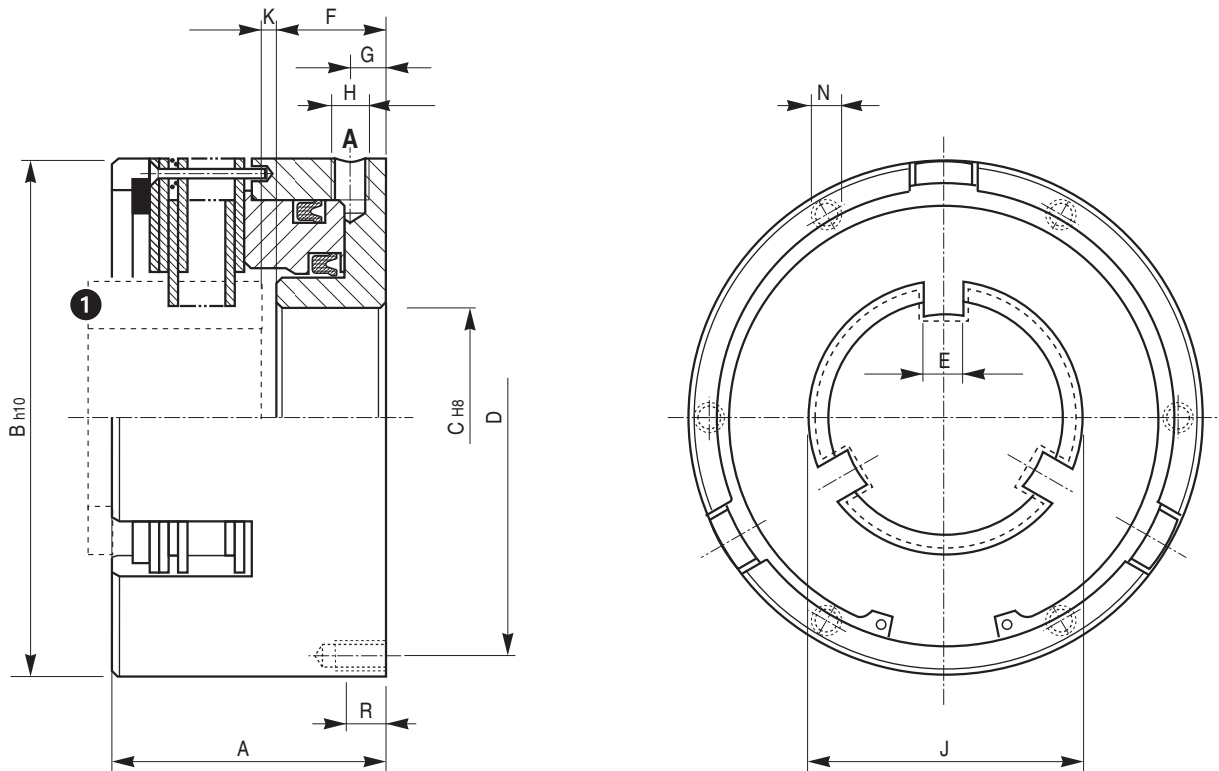

A = Air supply

NOTE - For run in oil-bath box, the brake disks are all made of steel

□□□	Torque Ms(Nm)	Working pressure bar	R.P.M. max	Cylinder volume (cm <sup>3</sup> )	Internal plates N.	Weight (kg)	Hubon demand ①
002	95	6	3000	5	5	1,8	MF2
003	150	6	2800	9	6	2,6	MF3
004	300	6	2400	13	6	4,0	MF4
006	650	6	2000	22	6	6,0	MF6
008	1200	6	1800	33	7	11,1	MF8/10
010	2400	6	1400	57	7	21,4	MDF-N230/S (*)

□□□	A	B	C	D	E	F	G	H	J	K	N n° x Ø	R max
002	56	92	40	83	9	24	7	1/8"	47,15	3	4 x M5	10
003	60	108	50	98	9	23	7	1/8"	55	3	6 x M6	10
004	66	122	55	112	12	26,5	7	1/8"	66	3	9 x M5	10
006	75	148	65	138	14	32,5	9,5	1/4"	86	3,5	9 x M6	12
008	94	188	100	174	12,3	37	9	1/4"	100,5	4	9 x M8	16
010	105	248	150	232	(*)	43	9	1/4"	140	5	12 x M10	16