



Airflex® DBA Description



Model DBA brakes are spring applied, pressure released, disc style brakes. They develop equal torque in either direction of rotation. Their torque and thermal capacities allow them to be used in the most demanding applications.

Brake construction and operation is shown in the figure. Pressurizing the brake compresses the brake springs and withdraws the clamping plates from the brake discs. Standard brakes are furnished with either one or two discs, which are free to move axially.

Model DBA uses a rubber diaphragm to form the releasing pressure chamber and to serve as the releasing piston. Brake friction material is attached to stationary components. Brake discs are either solid or ventilated. The disc type is indicated by an S for solid, or V, for ventilated, in the brake model designation. Solid discs are used in applications requiring a heat sink and/or where engagement is infrequent. Ventilated discs are recommended for cyclic applications.

Torque ratings listed are for brakes with a standard compliment of springs. The quantity of springs can be varied to customize the torque of the brake to suit a particular application. Consult the factory for brake torque of units with non-standard spring configurations.

Brake sizes are indicated by the number of brake discs and the disc diameter in inches. For instance, size 229DBA has two discs 29 inches in diameter.



Features

Large friction area.

Allows brakes to absorb and dissipate high energy loads associated with high cyclic and high inertia stops.

Minimal adjustment required for lining wear.

Single disc units require no wear adjustment and dual disc units require only one wear adjustment during the long life of the friction material.

Where used:

- Can making machines
- Draglines
- Power shovels
- Conveyors
- Power presses



Airflex® DBA Component parts

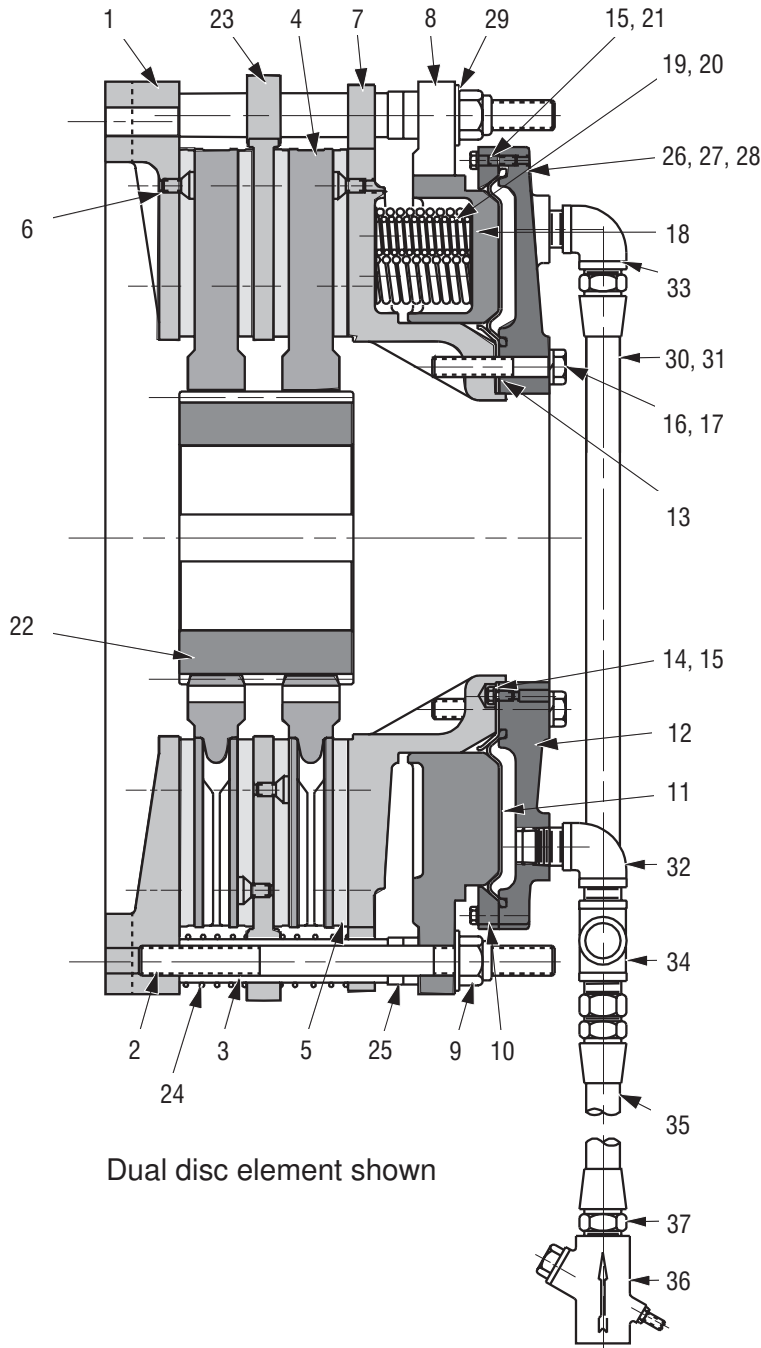

Item Number	Description
1	Mounting Flange
2	Stud
3	Clamp Tube
4	Disc
5	Friction Disc
6	Flat Head Screw
7	Pressure Plate
8	Spring Housing
9	Locknut
10	Outer Clamp Ring
11	Diaphragm
12	End Plate
13	Inner Clamp Ring
14	Hex Head Screw
15	Lockwasher
16	Hex Head Screw
17	Lockwasher
18	Spring Retainer Plate
19	Inner Spring
20	Outer Spring
21	Hex Head Screw
22	Gear
23	Reaction Plate
24	Release Spring
25	Wear Spacer
26	Name Plate
27	Self Tapping Screw
28	Warning Decal
29	Washer
30	Air Tube
31	Air Tube
32	90 Deg. Street Elbow
33	90 Deg. Male Elbow
34	Cross
35	Hose Assembly
36	Flow Control Valve
37	Bushing



Airflex® DBA Brake Elements



Form DBA808 Dimensional and Technical Data

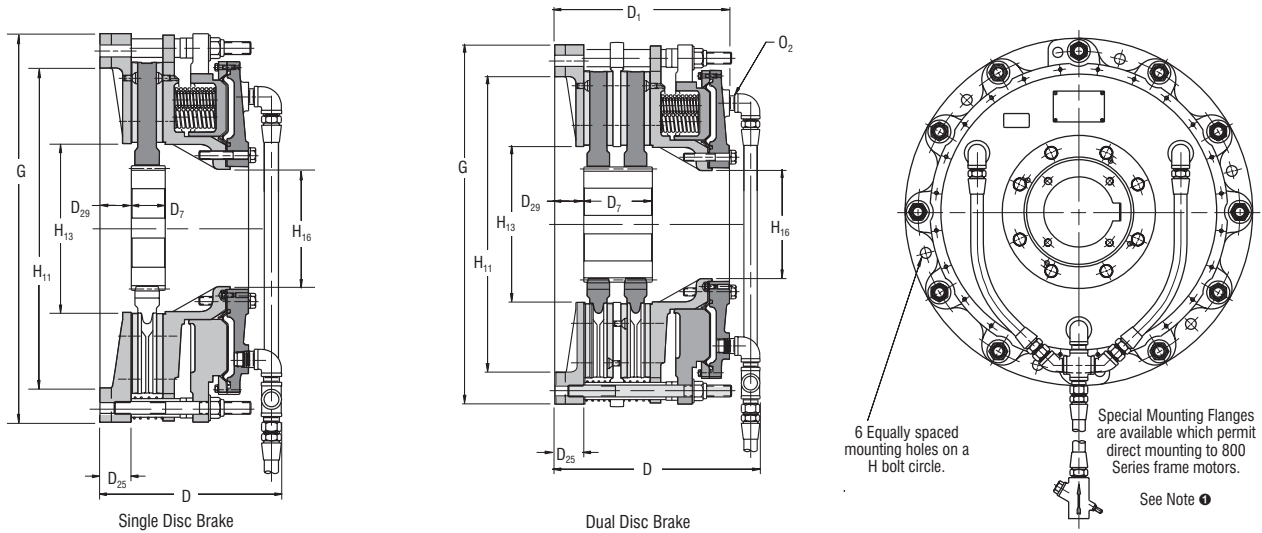

English	Dimensions in inches							
17DBA	2.00	21.000	17.25	10.00	5.38	24.998	0.78	1/2-14
21DBA	2.00	23.000	21.00	12.12	7.62	26.498	1.06	1-11 1/2
29DBA	2.75	31.000	28.00	14.75	10.25	33.998	1.06	1-11 1/2
Basic Size	D ₂₅	H	H ₁₁	H ₁₃	H ₁₆	G ②	L	O ₂ ③
17DBA	51	533	438	254	137	634,9	20	1/2-14
21DBA	51	584	533	308	194	673,0	27	1-11 1/2
29DBA	70	787	711	375	260	863,5	27	1-11 1/2
SI	Dimensions in millimeters							

English	Dimensions in inches								
117DBA	2.50	4.50	12.55	11.19	4.88	1.00	10.69	4.88	1.88
217DBA	2.75	4.13	15.77	14.41	6.50	1.88	13.41	6.50	1.88
121DBA	2.88	5.75	13.19	11.33	2.50	2.12	11.33	5.62	2.00
221DBA	3.63	5.63	16.47	14.61	5.63	2.12	14.23	5.62	2.25
129DBA	3.88	7.13	15.51	13.75	3.50	2.25	15.06	5.88	2.38
229DBA	4.88	7.19	19.13	17.38	7.12	2.25	18.06	7.00	3.12
329DBA	5.63	6.88	22.93		10.63	2.34			
Size	Min.	Max.	D	D ₁	D ₇	D ₂₉	D	D ₇	D ₂₉
	④ Bore Range ⑤		Ventilated Disc Types						
	Min.	Max.	D	D ₁	D ₇	D ₂₉	D	D ₇	D ₂₉
117DBA	64	114	319	284	124	25	272	124	48
217DBA	70	105	401	366	165	48	341	165	48
121DBA	73	146	335	287	64	54	288	143	51
221DBA	92	143	418	371	143	54	361	143	57
129DBA	99	181	394	349	89	57	383	149	60
229DBA	124	182	486	441	181	59	459	178	79
329DBA	143	175	582		270	59			
SI	Dimensions in millimeters								

Notes:

- ① All ventilated disc brakes are furnished with an approximate 15.5 inch (394 mm) length of flexible hose and a flow control valve having a 1-11 1/2 American National Pipe Thread port.
- ② Tolerance +0.000/-0.003 in (+0,00/-0,08 mm)
- ③ American National Pipe Thread
- ④ Minimum bore based on catalog rated torque and standard spring configuration.
- ⑤ Maximum bore based on catalog rated torque and flat key



Airflex® DBA Elements



Dimensional and Technical Data

English			lb in	psi	in ³	in ²	lb ft ²	lb		rpm
117DBAS	146148	413113	29300	85	100	270	18	95	410	2300
217DBAS	146152	413248	52600	85	100	540	35	160	455	2300
121DBAS	146145	413534	69800	85	160	406	42	130	610	1900
221DBAS	146151	413536	129300	85	160	812	80	270	565	1900
129DBAS	146162	413801	176700	100	310	890	152	325	950	1500
229DBAS	146163	414126	336200	100	310	1780	292	520	1150	1500
Size	① Part Number	Gear Part Number	M, Torque Rating ②③	Minimum Releasing Pressure	⑤ Releasing Volume	Friction Area	Wk ²	Weight		Maximum Speed
							Disc & Gear	Disc & Gear	Housing	
							J	Mass		
117DBAS	146148	413113	3310	5,9	1,64	1742	0,76	43	186	2300
217DBAS	146152	413248	5940	5,9	1,64	3483	1,47	72	206	2300
121DBAS	146145	413534	7890	5,9	2,62	2619	1,76	59	276	1900
221DBAS	146151	413536	14600	5,9	2,62	5237	3,36	122	256	1900
129DBAS	146162	413801	20000	6,9	5,08	5741	6,38	147	430	1500
229DBAS	146163	414126	38000	6,9	5,08	11481	12,26	236	521	1500
SI			Nm	bar	dm ³	cm ²	kg m ²	kg		rpm

English			lb in	in ³	in ²	lb ft ²	lb		rpm
117DBAV	146148	413113	20500	100	270	10	70	320	1300
217DBAV	146152	413248	38000	100	540	20	112	363	1300
121DBAV	146145	413534	52500	160	406	30	105	480	1000
221DBAV	146151	413535	96000	160	812	60	210	565	1000
129DBAV	146162	413683	113000	310	890	97	185	970	900
229DBAV	146163	413585	216000	310	1780	191	340	1150	900
329DBAV	146210	415080	339000	310	2670	285	495	1549	900
Size	① Part Number	Gear Part Number	M, Torque Rating ②③④⑥	⑤ Releasing Volume	Friction Area	Wk ²	Weight		Maximum Speed
						Disc & Gear	Disc & Gear	Housing	
						J	Mass		
117DBAV	146148	413113	2320	1,64	1742	0,42	32	145	1300
217DBAV	146152	413248	4290	1,64	3483	0,84	51	164	1300
121DBAV	146145	413534	5930	2,62	2619	1,26	48	217	1000
221DBAV	146151	413535	10800	2,62	5237	2,52	95	256	1000
129DBAV	146162	413683	12800	5,08	5741	4,07	84	439	900
229DBAV	146163	413585	24400	5,08	11481	8,02	154	521	900
329DBAV	146210	415080	38400	5,08	17223	11,97	224	703	900
SI			Nm	dm ³	cm ²	kg m ²	kg		rpm

Notes:

- ① Basic part number only. Does not include gear. Gear must be ordered separately with the bore and keyway requirements.
- ② Dynamic torque shown. Static torque approximately 1.15 greater. Torque values are for new linings. Torque decreases with lining wear. At the worn out condition, torque is approximately 0.66 of values shown.
- ③ Torque ratings are for units with a standard complement of springs. Consult factory for torque ratings of units with non-standard spring configurations.
- ④ Maximum allowable cylinder pressure is 120 psi (8,3 bar).
- ⑤ Absolute volume of releasing cavity.
- ⑥ Minimum releasing pressure 60 psi (4,1 bar).