



Airflex[®] Magnetic Clutches and Brakes



Element Descriptions

General

Airflex magnetic clutches and brakes are stationary field, multiple-disc units actuated by electromagnetic force. The stationary field eliminates the need for collector rings and brushes, thus doing away with mounting and service problems. The units can be furnished with disc packs for either wet or dry operation. Operation in oil is recommended where high speeds, high cyclic rates and heavy loads are encountered and where wear must be minimized.

Type SC

Clutch design is illustrated in the component parts diagram. The coil 5 and coil housing 6 are supported and held in alignment by the inner race of bearing 3. These components are held stationary by holding arm 1. Items 7, 8, 15, 16, 18 and 19 are mechanically attached to clutch body 2 which in turn is keyed to the driving shaft. Driving discs 15 and friction discs 17 are disengaged by released springs 18.

Energizing coil 5 sets up a magnetic flux circuit which attracts armature 8 towards outer field ring 7, compressing springs 18 and clamping the disc pack, causing driven gear 14 and its shaft to rotate.

De-energizing coil 5 disrupts the magnetic flux circuit allowing release springs 18 to disengage driven friction discs 17.

Type SC clutches are available in seven sizes. Torque ratings up to 8250 lbin (932 Nm)

Type SB

Type SB brakes are spring-applied magnetically-released units. Design is illustrated in the components parts diagram. Items 1, 2, 3, 9 and 12 are mechanically connected and are reacted to a stationary member by screws 10. Gear 7 and friction discs 8 are attached to the shaft to be braked.

Energizing coil 2 attracts armature 13, which in turn compresses springs 1 and releases the friction discs 8.

De-energizing the coil allows springs 1 to clamp the friction disc pack, braking the shaft.

Type SB brakes are available in two sizes. Torque ratings to 396 lbin (45 Nm).





Airflex® Magnetic Clutches and Brakes



Component Parts

SC Component Parts

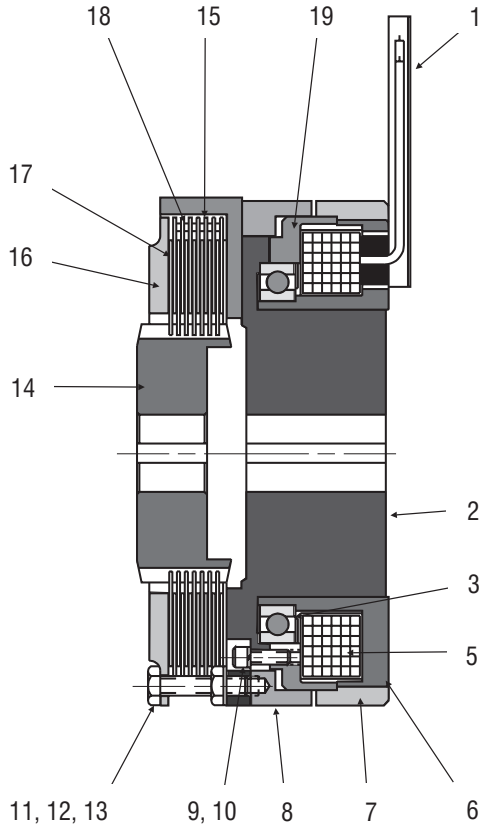

SB Component Parts

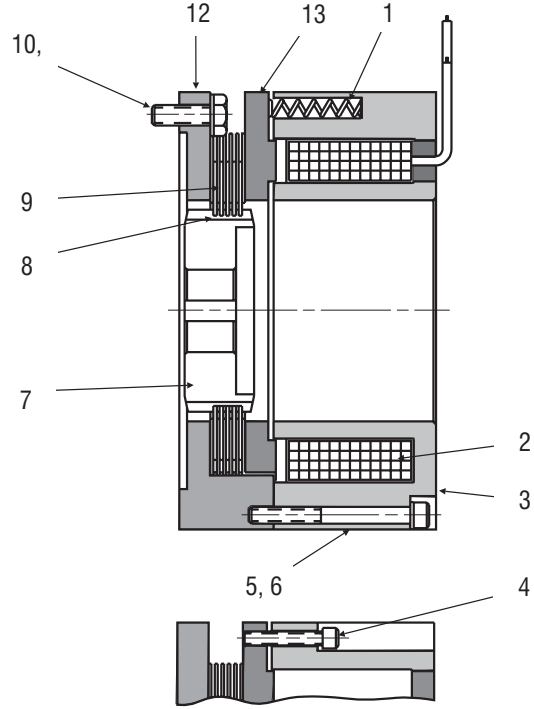

Item	Description
1	Holding Arm
2	Clutch Body
3	Bearing
4	Lube Retainer
5	Coil
6	Coil Housing
7	Outer Field Ring
8	Armature
9	Lockwasher
10	Socket Head Cap Screw
11	Hex Head Cap Screw
12	Hex Nut
13	Lockwasher
14	Driven Gear
15	Driving Disc
16	Pressure Plate
17	Friction Disc
18	Release Spring
19	Magnetic Flux Barrier

Item	Description
1	Spring
2	Coil
3	Coil Housing
4	Manual Release Screw
5	Socket Head Cap Screw
6	Lockwasher
7	Driven Gear
8	Friction Disc
9	Driving Disc
10	Hex Head Cap Screw
11	Lockwasher
12	Mounting Flange
13	Armature



Airflex® Type SC Magnetic Clutches



Technical Data

English			lb in				lb		Wk ²		
			Wet ²		Dry		Clutch	Gear	Primary Parts	Friction Discs	Gear
SC-275	147000	203522	55	70	85	100	2.1	0.1	1.54	0.09	0.02
SC-325	147001	203529	110	135	160	200	3.1	0.3	3.42	0.21	0.12
SC-375	147002	203531	275	340	365	420	4.8	0.3	7.09	0.34	0.22
SC-450	147003	203533	560	650	840	990	7.8	0.8	17.00	0.86	0.81
SC-550	147004	203535	1100	1400	1625	2100	13.5	1.1	42.00	4.11	1.28
SC-650	147005	203537	2200	3000	3300	4400	21.3	1.9	98.00	9.00	3.42
SC-775	147006	306346	4400	5500	6600	8250	32.9	2.9	212.00	26.00	9.23
Size	Part Number ¹	Gear Part Number	Dynamic	Static	Dynamic	Static	Weight		Wk ²		
			M, Torque @ Rated Amps								
			Dynamic	Static	Dynamic	Static	Mass		J		
SC-275	147000	203522	6,22	7,91	9,61	11,3	1,0	0,04	0,06	0,0037	0,0008
SC-325	147001	203529	12,4	15,3	18,1	22,6	1,4	0,1	0,14	0,01	0,01
SC-375	147002	203531	31,1	38,4	41,2	47,5	2,2	0,1	0,30	0,01	0,01
SC-450	147003	203533	63,3	73,5	94,9	112	3,5	0,4	0,71	0,04	0,03
SC-550	147004	203535	124	158	184	237	6,1	0,5	1,76	0,17	0,05
SC-650	147005	203537	249	339	373	497	9,6	0,9	4,12	0,38	0,14
SC-775	147006	306346	497	622	746	932	15	1,3	8,90	1,09	0,39
SI			Wet ²		Dry		Clutch	Gear	Primary Parts	Friction Discs	Gear
			Nm								

Size	Number of Discs		Max rpm	Response Time (Seconds)		Coil Data ⁴			
	Steel	Friction		Torque Build-up	Torque Decay	D.C. Voltage	Resistance Ohms	Current Amps	Power Watts
SC-275	4	4	6000	.089	.022	90	662	.136	12.2
SC-325	5	5	6000	.115	.029	90	502	.179	16.1
SC-375	5	5	5000	.180	.040	90	235	.383	34.5
SC-450	6	6	4000	.198	.052	90	235	.383	34.5
SC-550	6	6	3500	.280	.065	90	126	.715	64
SC-650	7	7	3000	.388	.078	90	140	.642	58
SC-775	7	7	2500	.440	.113	90	90	1.00	90

Notes:

- ¹ Basic number for wet operation. Add suffix "A" for dry operation. Gear not included.
- ² For optimum compatibility and performance, use plain mineral oil SAE 10 to 20.
- ³ Based upon minimum bore.
- ⁴ At 68°F (20°C).
- ⁵ Tolerance +0.000/-0.005 in (+0.00/-0.13 mm)
- ⁶ Tolerance \pm 0.005 in (\pm 0.13 mm)



Airflex® Type SC Magnetic Clutches



Dimensional Data

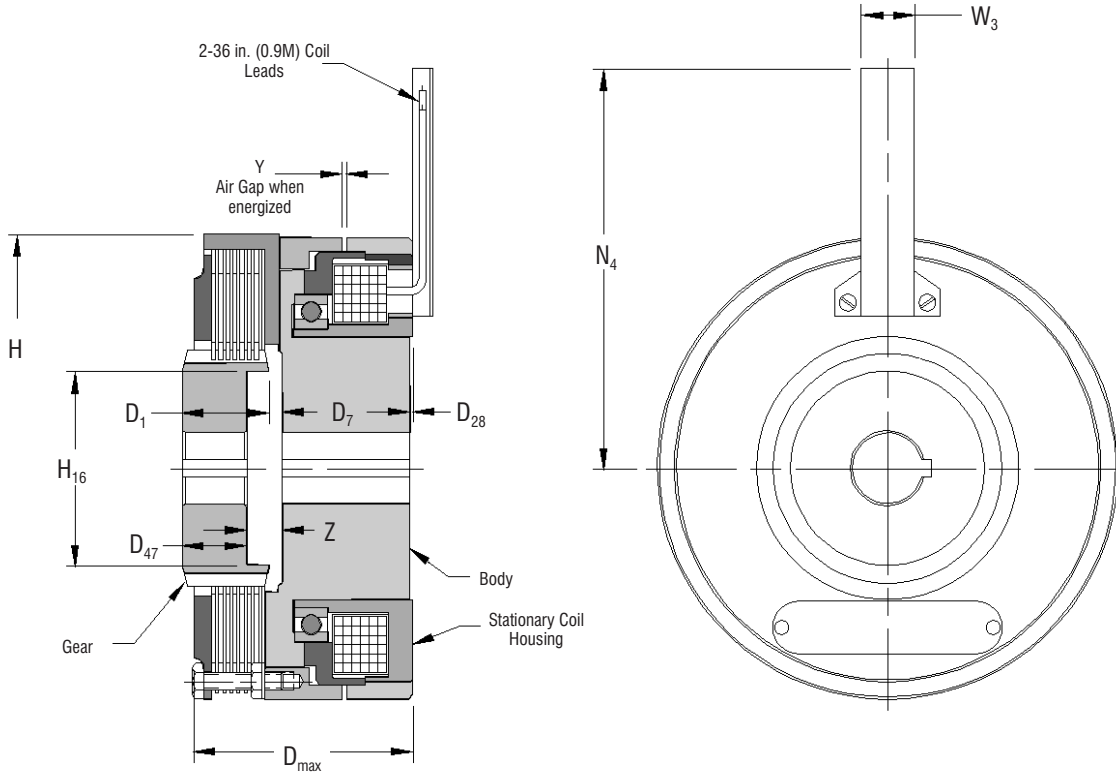

English	Dimensions in inches															
SC275	0.38	0.75	0.38	0.81	1.72	0.562	1.099	0.03	0.422	2.81	1.06	2.66	0.50	0.010	0.20	0.25
SC325	0.47	0.94	0.47	1.13	1.95	0.656	1.224	0.03	0.516	3.34	1.25	2.88	0.50	0.010	0.17	0.25
SC375	0.59	1.22	0.59	1.44	2.22	0.689	1.380	0.03	0.500	3.84	1.67	3.09	0.50	0.012	0.28	0.36
SC450	0.81	1.50	0.81	1.75	2.63	0.844	1.568	0.05	0.625	4.59	2.03	4.81	0.75	0.012	0.31	0.42
SC550	1.00	1.75	1.00	2.38	2.88	1.000	1.724	0.03	0.781	5.63	2.25	5.25	0.75	0.014	0.31	0.42
SC650	1.31	2.13	1.31	2.75	3.22	1.219	1.849	0.06	0.906	6.63	2.75	5.66	0.75	0.016	0.41	0.55
SC775	1.31	2.63	1.31	2.88	3.66	1.219	2.224	0.05	0.906	7.75	3.25	6.00	0.75	0.018	0.41	0.58
Size	Min.	Max.	Min.	Max.	D	⊕	⊕	D ₂₈	⊕	H	H ₁₆	N ₄	W ₃	Y	Min.	Max.
	Gear Bore		Body Bore			D ₁	D ₇		D ₄₇						Z	
	Min.	Max.	Min.	Max.		Min.	Max.		Min.						Max.	
SC275	10	19	10	21	44	14,3	27,9	1	10,7	71	27	68	13	0,3	5	6
SC325	12	24	12	29	50	16,7	31,1	1	13,1	85	32	73	13	0,3	4	6
SC375	15	31	15	37	56	17,5	35,1	1	12,7	98	42	78	13	0,3	7	9
SC450	21	38	21	44	67	21,4	39,8	1	15,9	117	52	122	19	0,3	8	11
SC550	25	44	25	60	73	25,4	43,8	1	19,8	143	57	133	19	0,4	8	11
SC650	33	54	33	70	82	31,0	47,0	2	23,0	168	70	144	19	0,4	10	14
SC775	33	67	33	73	93	31,0	56,5	1	23,0	197	83	152	19	0,5	10	15
SI	Dimensions in millimeters															



Airflex® Type SB Magnetically Released



Technical Data

English			lbin		lb		lbft ²	
			Wet ²	Dry	Brake	Gear	Friction Discs	Gear
SB450	147008	203531	84	120	5.8	0.3	0.34	0.22
SB525	147009	203533	228	396	12.4	0.8	0.71	0.81
Size	Part ¹ Number	Gear Part Number	M _s Static Torque		Weight		Wk ²	
					Mass	³	J	
SB450	147008	203531	9.49	13.6	2.6	0.1	0.01	0.01
SB525	147009	203533	25.8	44.7	5.6	0.4	0.03	0.03
SI			Wet ²	Dry	Brake	Gear	Friction Discs	Gear
			Nm		kg		kgm ²	

Size	Number of Discs		Max rpm	Discs & Gear Same As	Response Time (Seconds)		Coil Data ⁴			
	Steel	Friction			Torque Build-up	Torque Decay	D.C. Voltage	Resistance Ohms	Current Amps	Power Watts
SB-450	6	5	5000	SC-375	.035	.055	90	304	0.30	26.6
SB-525	6	5	4000	SC-450	.110	.110	90	190	0.47	42.7

Notes:

- ¹ Basic number only. Gear not included.
- ² For optimum compatibility and performance, use plain mineral oil SAE 10 to 20.
- ³ Based upon minimum bore.
- ⁴ At 68°F (20°C). Coil can be energized continuously without overheating.
- ⁵ Tolerance +0.000/-0.005 in (+0,00/-0,13 mm)
- ⁶ Tolerance +0.000/-0.002 in (+0,00/-0,05 mm)
- ⁷ American National Standard for Unified Screw Threads.



Airflex® Type SB Magnetically Released



Dimensional Data

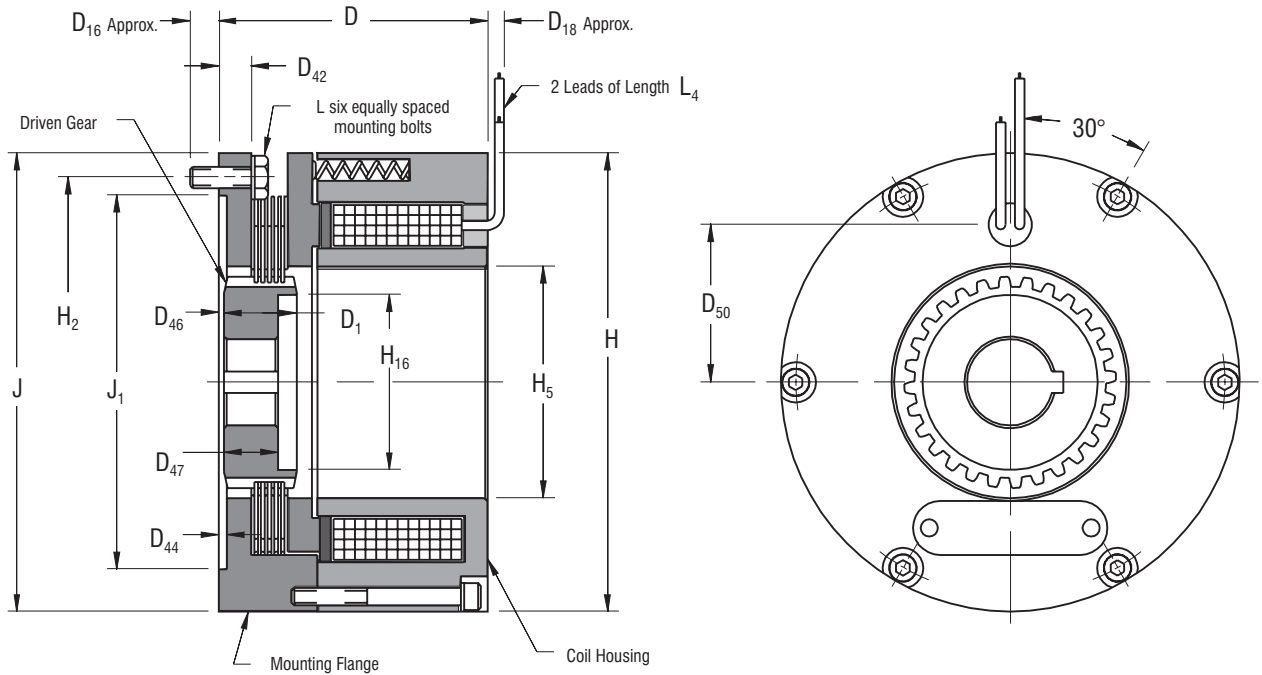

English	Dimensions in inches																				
SB450	0.594	1.219	2.66	0.688	0.28	0.19	0.31	0.094	0.06	0.25	0.500	1.45	4.53	4.00	2.10	1.67	4.53	3.50	10-24	24	
SB525	0.625	1.500	3.13	0.844	0.33	0.19	0.38	0.094	0.02	0.31	0.625	1.83	5.31	4.75	2.25	2.03	5.31	4.33	1/4-20	36	
Size	Min. Max.																				
	Bore Range		D	⑤	D ₁₆	D ₁₈	D ₄₂	D ₄₄	Min. Max.		⑤	D ₄₇	D ₅₀	H	H ₂	H ₅	H ₁₆	⑥	⑦	L	L ₄
	Min. Max.																				
SB450	15,0	30,8	67	17,4	7	5	8	2,4	2	6	12,7	37	115	101	53	42	115	89	10-24	607	
SB525	15,8	38,0	79	21,4	8	5	9	2,4	0	8	15,8	46	134	120	57	51	134	110	1/4-20	911	
SI	Dimensions in millimeters																				