

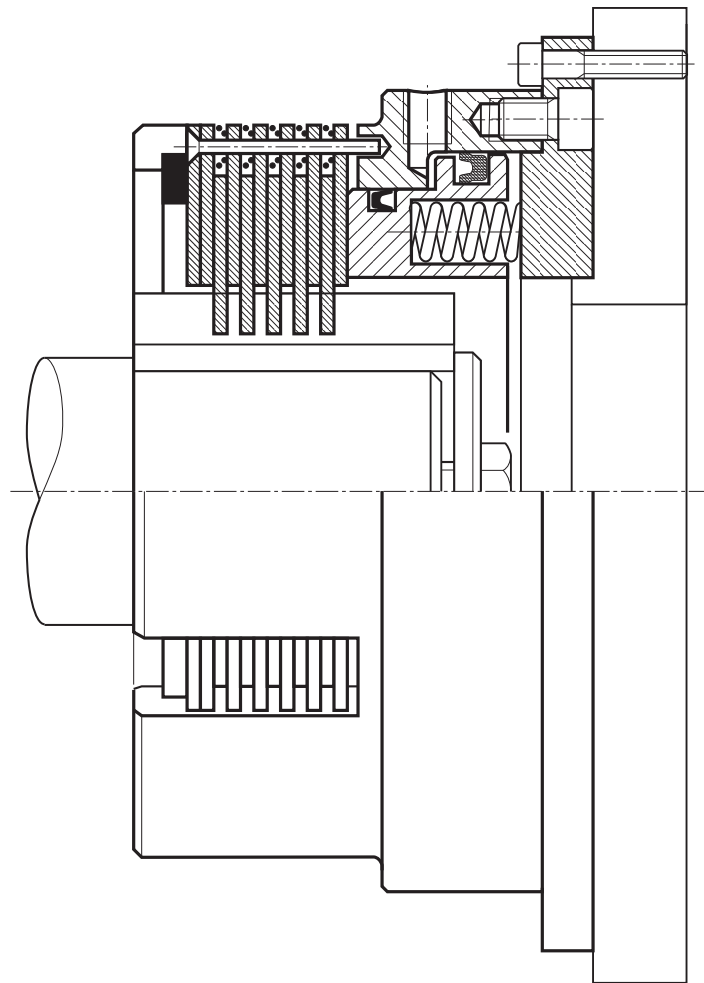

**FRENO HIDRÁULICO
MULTIDISCO NEGATIVO**

FOL-N/C-BF





FRENO HIDRÁULICO MULTIDISCO NEGATIVO FOL-N/C-BF

SPRING-APPLIED, HYDRAULICALLY RELEASED MULTI-DISK BRAKES

Spring-applied brakes realize instantly lock a machinery or part of it in an emergency, simply cutting off pressure supplied to the brake actuator.

They also may be used as parking brakes during scheduled stops or for maintenance.

In working conditions, this type of brake is engaged by the action of thrust springs, which guarantee the nominal braking torque.

Releasing of the brake occurs when air/oil under pressure is supplied to the working cylinder through the supply bore «A» located on the external diameter of the working cylinder itself.

For dry applications, this series of multi-disc brakes makes use of a combination of bronze/steel disks that actually allows you to work without lubrication.

In order to obtain a complete disengagement of the brake, you must guarantee the release pressure suggested in this catalogue; we also suggest to mount the command valve, which must be equipped with a blow-off device, as close as possible to the working cylinder, to quickly and precisely disengage the brake.



FRENO HIDRÁULICO MULTIDISCO NEGATIVO FOL-N/C-BF

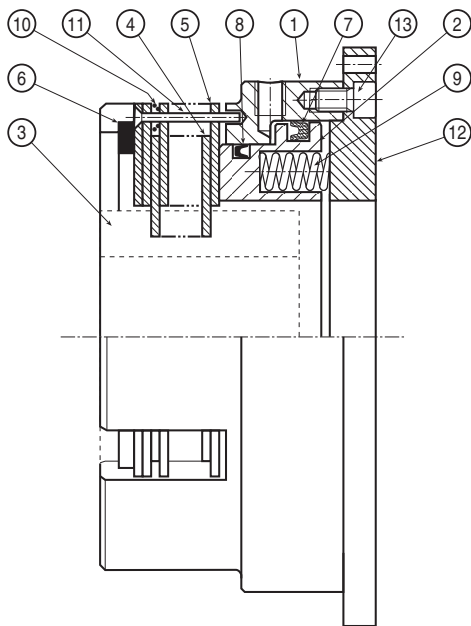

PARTS LIST

1. CYLINDER
2. PISTON
3. CENTRAL HUB (ON DEMAND)
4. INNER DISK
5. OUTER DISK
6. INNER SAFETY RING
7. OUTER SEAL RING
8. INNER SEAL RING
9. SPRING
10. DISK SEPARATING SPRING
11. SPRING GUIDE PIN
12. MOUNTING FLANGE
13. MOUNTING FLANGE LOCKING SCREW

EXAMPLES OF MOUNTING

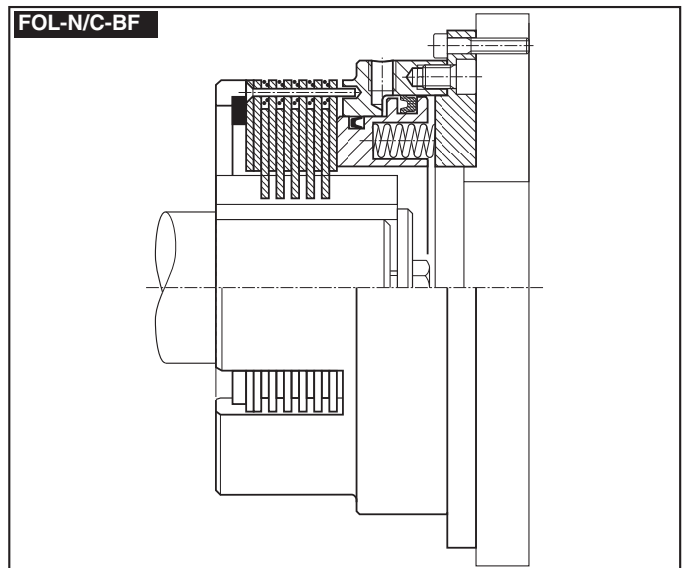

MOUNTING

For this model, mounting procedure consists in drilling the proper number of threaded holes to fix the brake mounting flange to the machinery or other fixed support by means of screws or bolts. To center correctly the mounting flange upon the machinery is very important. You have to mount a milled hub (on demand) to the rotating shaft; this hub inserts into the fins of the inner disks. Please, always refer to mounting examples.



FRENO HIDRÁULICO MULTIDISCO NEGATIVO FOL-N/C-BF

MODEL	FOL-N □□□ /C-BF
CODE	03.70.□□□.02

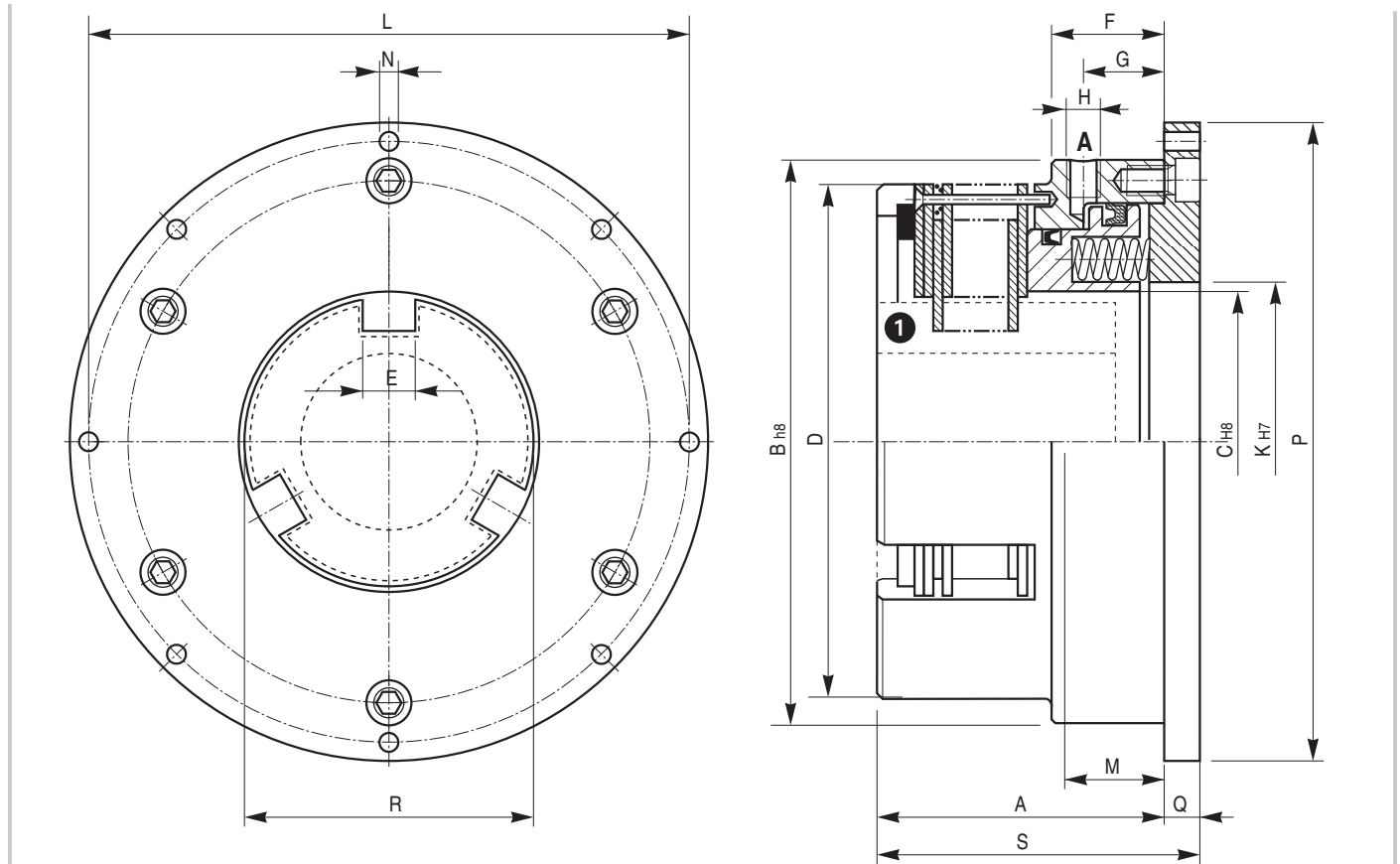

A = Air supply

NOTE - For run in oil-bath box, the brake disks are all made of steel

□□□	Torque Ms(Nm)	Release pressure bar	R.P.M. max	Cylinder volume (cm³)	Internal plates N.	Weight (kg)	Hub on demand ①
002	95	6	3000	14	5	3,9	MF2
003	150	6	2800	18	6	5,3	MF3
004	300	6	2400	35	6	6,7	MF46
006	650	6	2000	41	6	13,5	MF6
008	1200	6	1800	77	6	23,7	MF8/10
010	2400	6	1400	135	7	35,4	MDF-N230/S (*)

□□□	A	B	C	D	E	F	G	H	K	L	M max	N n° x Ø	P	Q	R	S
002	59,5	118	48	92	9	32	24	1/8"	50	130	33,5	6 x 6,5	142	10	47,15	69,5
003	67,5	135	57	108	9	32	24	1/8"	58	147	35,5	6 x 6,5	159	10	55	77,5
004	73	155	70	118	12	37	26	1/8"	72	168	40	8 x 6,5	184	10	66	83
006	92,5	192	87	148	14	42	31,5	1/4"	89	207	63	8 x 8,5	222	14	86	106,5
008	109,5	235	102	188	12,3	50,5	35	1/4"	110	250	59	12 x 8,5	265	14	100,5	123,5
010	116	280	150	248	(*)	58	42	1/4"	150	298	62	12 x 10,5	316	15,5	140	131,5