

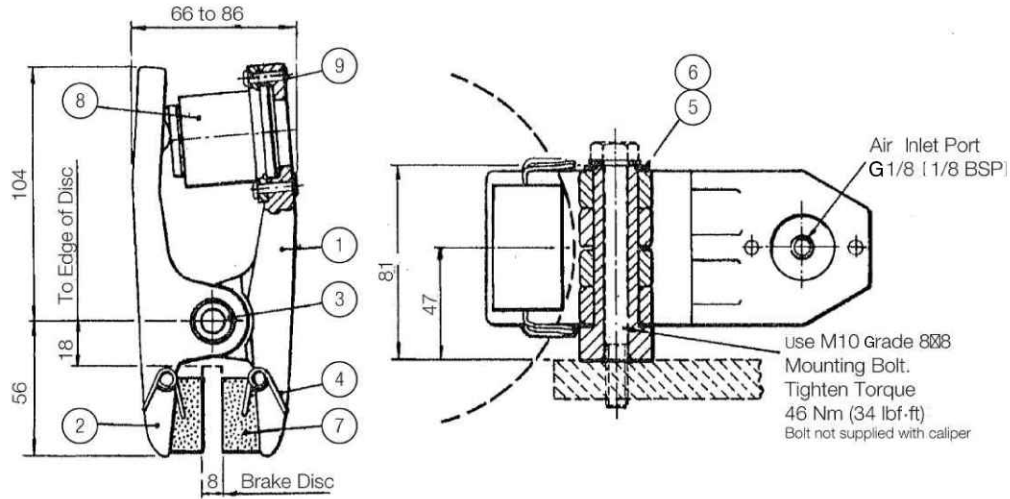

MUP DISC BRAKE CALIPER - Air Applied



Disc Brake Caliper Assembly Type MUP
Complete assembly (Caliper and thruster) Part No. 678919

Parts List

Item	Component	Part No.	Qty.
1	Arm (Thruster Side)	6640177	1
2	Arm (Opposite Side)	6640178	1
3	Pivot Post	8240039	1
4	Pad Retaining Spring	2450093	2
5	9/16" Plain Washer	4700209	1

Item	Component	Part No.	Qty.
6	M10 Plain Washer	4700208	1
7			
8	Air Thruster	7200525	1
9	5/32" x 3/4" Rivet	6540095	2
10			

Technical Data MUP:

Complete assembly (Caliper and thruster) Part No. 6780919.
 Weight (complete assembly)-0.800kg
 Minimum brake disc diameter-150mm
 Disc thickness (Standard) -8mm
 New pad dimensions-30x50x21mm thick
 Brake pad wear allowance-5mm each pad
 Total pad area -30cm²
 Maximum pressure-7 bar (100 psi)
 Volume displacement of thruster at maximum (6mm) stroke-3.8 ml

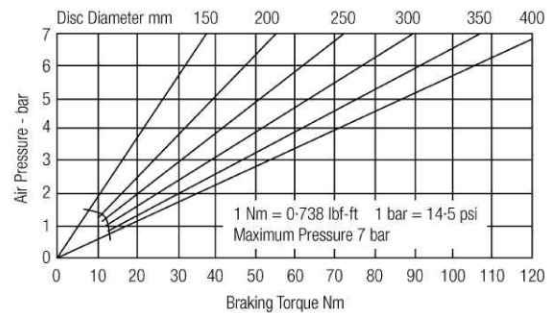

Brake Performance of MUP Disc Brake Caliper

The ratings shown on the above graph are based on fully bedded-in pads and coefficient of friction of 0.38

Braking Force 7 bar (100 psi) = 680 N (153 lbf)

Brake torque (Nm) = Braking force (N)xeffective disc radius (m).

(Effective disc radius (m) = actual radius (m) -0.020).