



Airflex® DBB Description



Model DBB brakes are spring applied, pressure released, disc style brakes. They develop equal torque in either direction of rotation. Their torque and thermal capacities allow them to be used in the most demanding applications.

Brake construction and operation is shown in the figure. Pressurizing the brake compresses the brake springs and withdraws the clamping plates from the brake discs. Standard brakes are furnished with either one or two discs, which are free to move axially.

Model DBB uses a conventional piston design to release the brake discs. The rotating component of the DBB style brake is a very low inertia friction disc core with riveted on friction discs. The low inertia of the rotating components coupled with the high heat sink capacity of the stationary members allow these units to provide superior performance in high cyclic applications. In applications requiring higher speed operation or where precise balance of the rotating components is required, the DBBS style is offered, which utilizes a solid rotor and stationary friction material. Similar to the DBAS design, the DBBS should only be used for applications where brake engagement is non-cyclic.

Torque ratings listed are for brakes with a standard compliment of springs. The quantity of springs can be varied to customize the torque of the brake to suit a particular application. Consult the factory for brake torque of units with non-standard spring configurations.

Brake sizes are indicated by the number of brake discs and the disc diameter in inches. For instance, size 225DBB has two discs 25 inches in diameter.



Features

Low inertia friction disc assembly.

Reduces the overall inertia that must be stopped.

Optional split friction discs.

Allows removal of friction discs without disturbing other components of drive system in mid-shaft brake arrangement.

Long wearing, self lubricating PolyPak® seals.

Eliminates premature twisting failure and requires no external lubrication.

Where used:

- Bottling equipment
- Power Shovels
- Conveyors
- Shears
- Power Presses



Airflex® DBB Component Parts

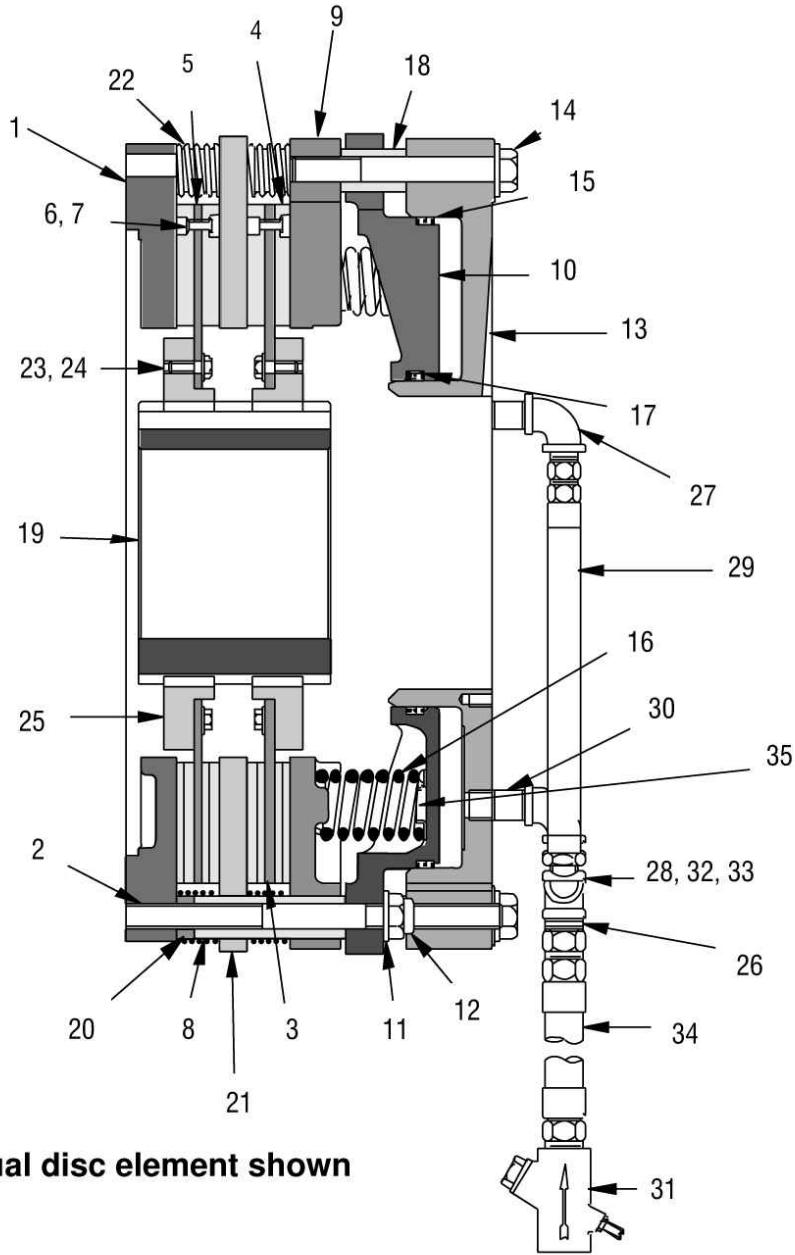

Dual disc element shown

Item Number	Description
1	Mounting Flange
2	Stud
3	Friction Disc Sub-Assembly
4	Friction Disc
5	Friction Disc Core
6	Rivet
7	Washer
8	Clamp Tube
9	Pressure Plate
10	Spring Housing
11	Flat Washer
12	Locknut

Item Number	Description
13	Cylinder
14	Hex Head Screw
15	Outer Seal
16	Spring
17	Inner Seal
18	Spacer Tube
19	Gear
20	Wear Spacer
21	Reaction Plate
22	Release Spring
23	Flat Washer
24	Hex Head Screw

Item Number	Description
25	Ring Gear
26	Pipe Nipple
27	Elbow
28	Pipe Cross
29	Hose Assembly
30	Pipe Nipple
31	Flow Control Valve
32	45 Deg. Street Elbow
33	Pipe Reducer
34	Hose Assembly
35	Spring Retainer



Airflex® DBB Brake Elements



Dimensional and Technical Data

English	Dimensions in inches				
109DBB	1.50	2.56	7.26	1.75	6.06
209DBB	1.94	2.56	8.70	4.00	7.53
309DBB	2.13	2.63	10.12	5.25	9.06
115DBB	2.50	4.38	4.38	2.88	7.52
215DBB	3.00	4.25	11.16	4.38	9.23
120DBB	3.00	5.88	10.87	3.00	9.37
220DBB	3.75	6.00	13.04	6.27	11.54
320DBB	4.25	5.88	15.21	8.25	13.68
420DBB	4.50	5.88	17.38	10.31	15.84
125DBB	3.88	7.50	12.07	3.50	10.57
225DBB	4.88	7.56	14.38	7.00	12.88
325DBB	5.50	7.50	16.69	9.31	15.19
425DBB	5.88	7.50	19.00	12.00	17.50
138DBB	6.00	11.00	16.25	5.00	14.25
238DBB	7.38	10.88	19.05	9.00	17.05
338DBB	8.38	10.63	21.85	12.00	19.73
438DBB	9.06	10.63	24.65	5.00	22.52
Size	Min.	Max.	D ^⑤	D ₁	W ₄ ^⑤
	Bore Range				

SI	Dimensions in millimeters				
109DBB	38	65	184	44	154
209DBB	49	65	221	102	191
309DBB	54	67	202	133	230
115DBB	64	111	242	73	191
215DBB	76	108	283	111	235
120DBB	76	149	276	76	238
220DBB	95	152	331	159	292
320DBB	108	149	386	210	347
420DBB	114	149	441	262	402
125DBB	99	191	307	89	268
225DBB	124	192	365	178	327
325DBB	140	191	424	236	386
425DBB	149	191	483	305	445
138DBB	152	279	413	127	362
238DBB	187	276	484	229	433
338DBB	213	270	555	305	501
438DBB	230	270	626	381	572
Size	Min.	Max.	D ^⑤	D ₁	W ₄ ^⑤
	Bore Range				

English	Dimensions in inches							
9DBB	1.00	0.25	①	3.12	12.125	8.375	12.37	3/8-18
15DBB	1.47	0.38	0.38	6.00	18.375	14.375	18.94	1/2-14
20DBB	1.50	0.38	1.00	8.50	23.250	18.250	23.82	1/2-14
25DBB	1.75	0.25	0.75	11.50	30.630	24.375	30.89	1/2-14
38DBB	2.45	0.25	1.25	16.50	44.750	36.375	45.01	3/4-14
Size	D ₃₁	D ₄₄	D ₄₅	H ₁₆	J ^②	J ₁ ^③	J ₂ [▼]	O ₂ ^④
9DBB	25	6	①	79	308.0	212.7	314	3/8-18
15DBB	37	10	10	152	466.7	365.1	481	1/2-14
20DBB	38	10	25	216	590.6	463.5	605	1/2-14
25DBB	44	6	19	292	778.0	619.1	785	1/2-14
38DBB	62	6	32	419	1136.7	923.9	1143	3/4-14

Mounting Bolt Circles

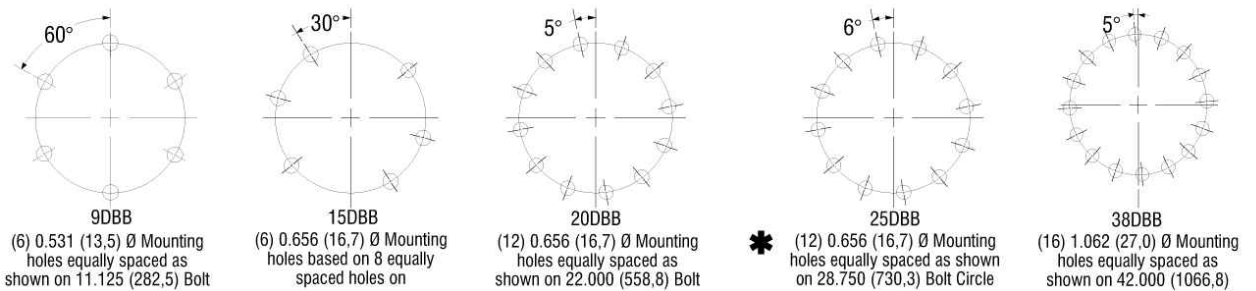

Notes:

- ① 0.50 in (13mm) for 109 DBB
0.25 in (6mm) for 209 DBB
0.00 in (0mm) for 309 DBB
- ② Tolerance +0.000/-0.003 in (+0.00/-0.08 mm)
- ③ Tolerance +0.003/-0.000 in (+0.08/-0.00 mm)
- ④ American National Pipe Thread.
- ⑤ Brake in disengaged position.
- ⑥ All DBB brakes can be supplied plumbed as shown with a flow control valve having American National Pipe thread ports of 1/2-14 for size 9DBB, 3/4-14 for sizes 15DBB, 20 DBB, 25DBB and 1-11 1/2 for size 38DBB
- ⑦ Basic part number only. Does not include gear. Gear must be ordered separately with the bore and keyway requirements.
- ⑧ Dynamic torque shown. Static torque approximately 15% greater. Torque values are for new linings. Torque decreases with lining wear. At the worn out condition, torque is approximately 0.66 of values shown.
- ⑨ Torque ratings are for units with standard complement of ⑩ springs. Consult factory for torque ratings of units with non ⑩ standard spring configurations.
- ⑩ Maximum allowable cylinder pressure is 120 psi (8,3 bar).
- * (12) 0.781 (19,8) Diameter mounting holes equally spaced as shown on 28.75 (730,3) Bolt circle
- ▲ Absolute volume of releasing cavity.
- ▼ Maximum diameter of "as cast" surfaces.
- ◆ Some high torque applications of three and four disc elements require additional support on the cylinder side of the unit. Contact your local Airflex representative for more details.
- See notes 4 & 5 on revised page E-3



Airflex® DBB Brake Elements



Dimensional and Technical Data

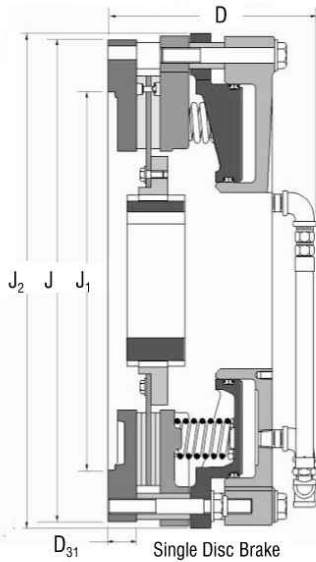

Single Disc Brake

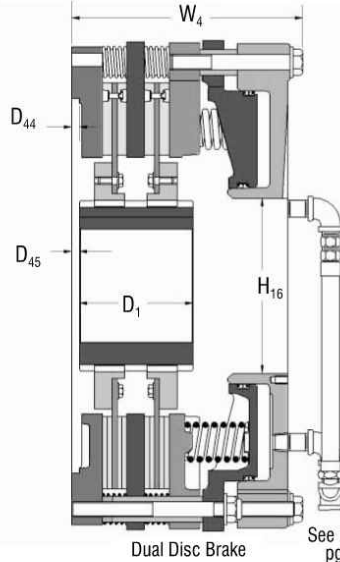

Dual Disc Brake

See Note on pg. E-7

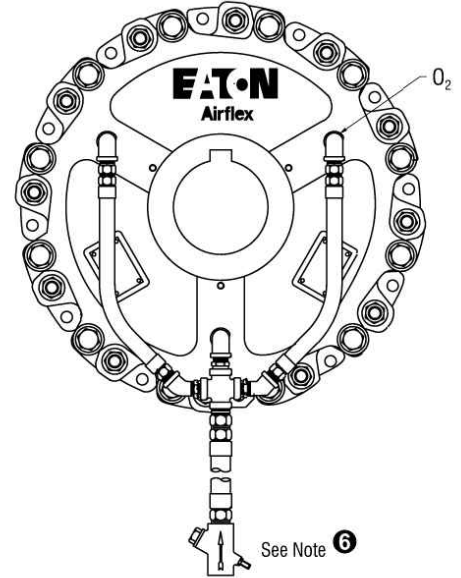

See Note 6

English	lb · in	psi	in ³	in ²	lb · ft ²	lb	rpm			
109DBB	146333	415313	7500	60	30	96	0.5	9	115	3000
209DBB	146334	415314	14000	60	30	192	1	18	145	3000
309DBB	146380	416481	19400	60	30	288	1.83	27	180	3000
115DBB	146222	415454	30000	60	75	238	5	35	225	2400
215DBB	146337	415302	57000	60	75	476	10	64	275	2400
120DBB	146299	415900	53500	60	133	334	17	40	385	1850
220DBB	146300	416059	101500	60	133	668	33	67	487	1850
320DBB	146378	416304	149000	60	133	1002	49	213	590	1850
420DBB	146379	416471	180000	60	133	1336	65	102	695	1850
125DBB	146315	416073	115300	60	259	600	47	78	705	1400
225DBB	146327	416074	219000	60	259	1201	93	148	935	1400
325DBB	146370	416223	303000	60	259	1802	139	403	1120	1400
425DBB	146381	416477	390000	60	259	2403	185	280	1250	1400
138DBB	146295	416068	420000	60	612	1322	287	203	1955	950
238DBB	146296	416069	800000	60	612	2644	562	340	2325	950
338DBB	146386	416241	1153000	60	612	3966	837	1087	3280	950
438DBB	146387	416464	1470000	60	612	5288	1112	1424	3850	950

Size	Part Number	Gear Part Number	M _r Torque rating ^{⑧⑨}	Minimum releasing pressure ^⑩	Releasing Volume	Friction Area	Wk ² Weight		Housing	Maximum speed
							Disc & Gear			
							J	Mass		
109DBB	146333	415313	847	4,1	0,49	619	0,02	4	52	3000
209DBB	146334	415314	1581	4,1	0,49	1238	0,04	8	66	3000
309DBB	146380	416481	2192	4,1	0,49	1858	0,07	12	82	3000
115DBB	146222	415454	3387	4,1	1,23	1535	0,21	16	102	2400
215DBB	146337	415302	6435	4,1	1,23	3070	0,42	29	125	2400
120DBB	146299	415900	6040	4,1	2,18	2154	0,71	18	175	1850
220DBB	146300	416059	11459	4,1	2,18	4309	1,39	30	221	1850
320DBB	146378	416304	16822	4,1	2,18	6463	2,06	97	277	1850
420DBB	146379	416471	20338	4,1	2,18	8617	2,73	46	315	1850
125DBB	146315	416073	13017	4,1	4,25	3870	1,97	35	320	1400
225DBB	146327	416074	24725	4,1	4,25	7746	3,91	67	424	1400
325DBB	146370	416223	44031	4,1	4,25	11623	5,84	183	508	1400
425DBB	146381	416477	44067	4,1	4,25	15499	7,77	127	567	1400
138DBB	146295	416068	47418	4,1	10,03	8527	12,05	92	887	950
238DBB	146296	416069	90320	4,1	10,03	17054	23,60	154	1055	950
338DBB	146386	416241	130282	4,1	10,03	25581	35,15	493	1488	950
438DBB	146387	416464	166101	4,1	10,03	34108	46,70	646	848	950

SI	n · m	bar	dm ³	cm ²	kg · m ²	kg	rpm
----	-------	-----	-----------------	-----------------	---------------------	----	-----