

# LIMITADOR DE PAR

# "FU" IBERICA, S.L.

Consisten en discos, tuerca, ferodos, resortes y rodamiento que protegen los equipos de transmisión de fuerzas importantes que podrían dañarlos. Se deslizan automáticamente cuando hay sobrecarga.

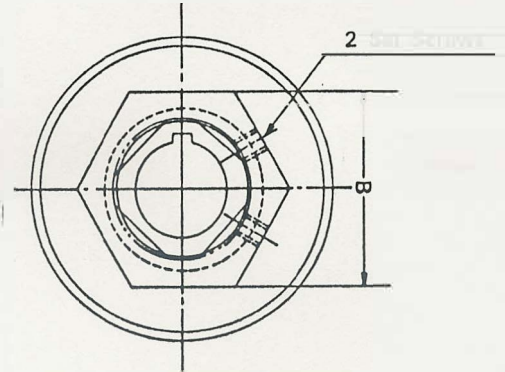
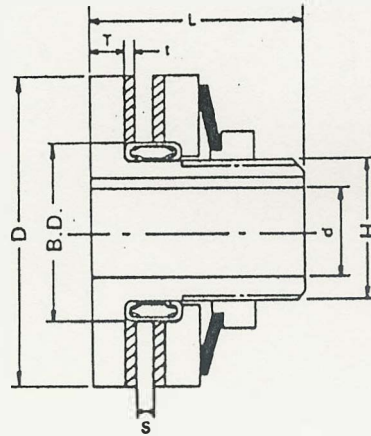
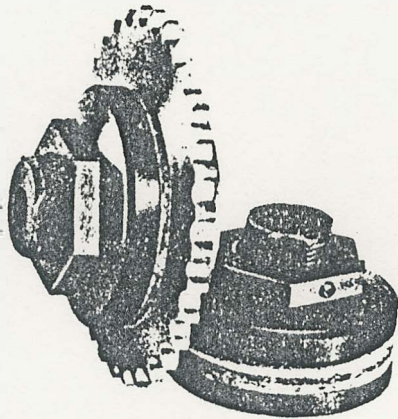

Torque Limiter NO.	Torque				Bore d		Dimensions-mm						No. of Spring	Needle Bearing		Width between linings S		Weight kg.
	min.		Max.											No.	Outer dia B.D.	min.	max.	
	Nm	Lbs.ft	Nm	Lbs.ft	min.	max.	D	L	T	H	B	t		No.	Outer dia B.D.	min.	max.	
TR- 5	9	7	49	36	8	19	57	50	9.5	25.4	35	3.2	1	B- 168	31.75	3	12	0.5
TR- 7	19	14	69	51													10	
TR- 13	29	22	128	94	10	25	86	60	9.5	38.0	54	3.2	1	B-2410	47.63	6	16	1.4
TR- 24	49	36	235	174													17	
TR- 26	59	43	255	188	17	35	114	70	9.5	47.63	67	3.2	1	B-3010	57.15	8	20	2.5
TR- 39	78	58	383	282													21	
TR- 44	59	43	432	318	21	41	152	90	13.0	63.5	85	4.5	1	NB-4012	73.02	4.5	28	5.7
TR- 60	176	130	589	434													23	
TR- 75	157	116	736	543	23	64	190	115	13.0	88.9	120	4.5	1	B-5617	101.60	4.5	48	10.6
TR-105	176	130	1030	760													10	
TR-201	29	22	128	94	10	35	94	60	8.0	50.0	67	3.0	1	NK-5020	58.0	7	16	1.9
TR-202	64	47	255	188													2	

## SERIES DE TIPO TRD

Uniones Maxton con limitadores de par protegen los componentes de equipos independientemente instalados de sobrecarga y uso excesivo causado por torsión de árboles como resultado de desalineamiento. Véase limitador de par.

Unión No.	Limitador Máx.		L	O.D. Máx.	Nota
	Limitador d Máx.	Piñón D Máx.			
T R D 4018	16	35	76	85	No. de resorte1:#TR- 5 No. de resorte2:#TR- 7
T R D 5022	22	55	98	127	No. de resorte1:#TR- 13 No. de resorte2:#TR-24
T R D 6024	35	70	109	164	No. de resorte1:#TR 26 No. de resorte2:#TR-39
T R D 8022	41	90	139	202	No. de resorte1:#TR- 44 No. de resorte2:#TR-60
T R D 10022	64	120	177	253	No. de resorte1:#TR-75 No. de resorte2:#TR-105

