

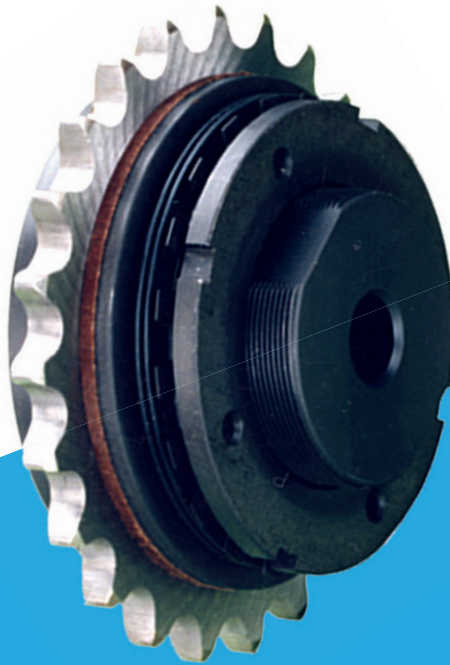

ComInTec[®]
Safety in Power Transmission

FRICITION TORQUE LIMITER

up to 23 KNm and 140 mm bore diameters



ED. 07/2021

DF

DF - friction torque limiter: introduction



- Simple and economic friction torque limiter.
 - Suitable for dusty conditions without need of timing between gearbox and output.
 - Silent overload without vibration.
 - Protection in both rotation directions.
 - Asbestos-free friction discs.
 - Simple and precise torque setting by adjusting the locking ring.
 - Innovative calibration system by "H dimension" for an immediate calibration of the device.
- ON REQUEST
- Complete with transmission gear, fully turned and mounted (plate wheel, pulley, gear pair).
 - Possibility of connections with bore and keyway, locking assembly or other locking systems.
 - Different types of friction discs for specific applications.
 - Anti-corrosive surface treatments or stainless steel version for special requirements.



Sliding safety coupling where a plate wheel, pulley or other transmission component is interposed between two friction rings. Upon reaching the torque sliding ensures continuity in the transmission without damaging the components. The minimum to have a low cost protection.

MAIN APPLICATIONS

- Forming machines.
- Conveyors.
- Automotive.
- Agricultural machines, woodworking machines.

ADVANTAGES AND BENEFITS

- Protects the motor-gearbox in case of accidental collision.
- Protects the film of wrapping machines in case of higher tension.
- Absorbs static torques without disengaging.
- Protects the gear in case of short product jam.

FRICION RINGS

- STD (standard): friction rings used for the torque values indicated in the catalogue. Optimum performance ratio torque / life.
 - ▲ ○ LD (long life): same performance in torque respect std friction rings life greater than 5 times.
 - ▲ ○ LDX (extra long life): life greater than 150 times respect standard friction rings, but performance in torque reduced by of 70% (until size 3,115 DF).
- ▲ On request

	DF: Basic model for parallel shaft transmission, with plate wheels, gear pairs or pulleys.	From 1 to 23000 Nm 140 mm max bore	Page 9
	DF/SI: signaling on overload and automatic re-engaging possible.	From 3 to 23000 Nm 140 mm max bore	Page 10
	DF/TAC: in-line shaft connection, simple and economic.	From 1 to 23000 Nm 160 mm max bore	Page 11
	... + GAS: in-lineshaft connection with elastic coupling with high misalignments.	From 1 to 14000 Nm 125 mm max bore	Page 12
	... + GEC: in-line shaft connection with compact elastic coupling.	From 1 to 23000 Nm 160 mm max bore	Page 12

APPLICATION EXAMPLES

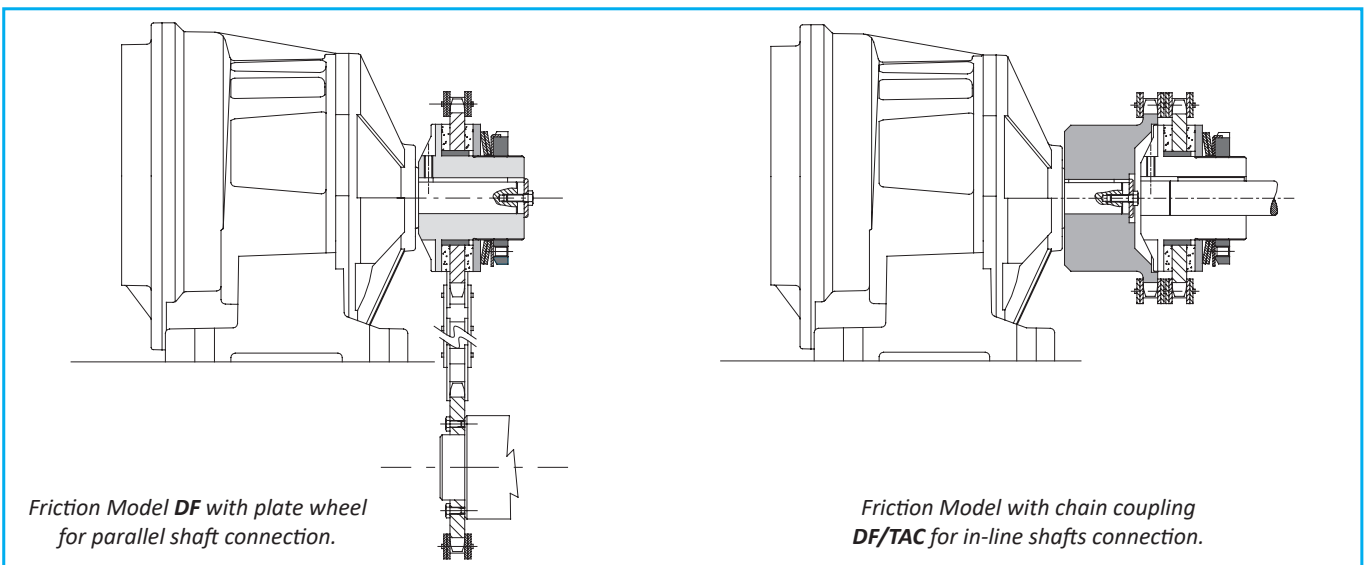

DF - friction torque limiter: technical data

- Simple and compact solution.
- Version with coil springs for fine adjustment: .../CM.
- Available in corrosion resistant: DF/EA or stainless steel version: DF-SS.
- Available with customized alignments ("L") interchangeable with other models on the market.
- Available with radial ring statically balanced: .../GR.
- Torque range from 1 to 23 KNm; max. bore $\phi 140$ mm.

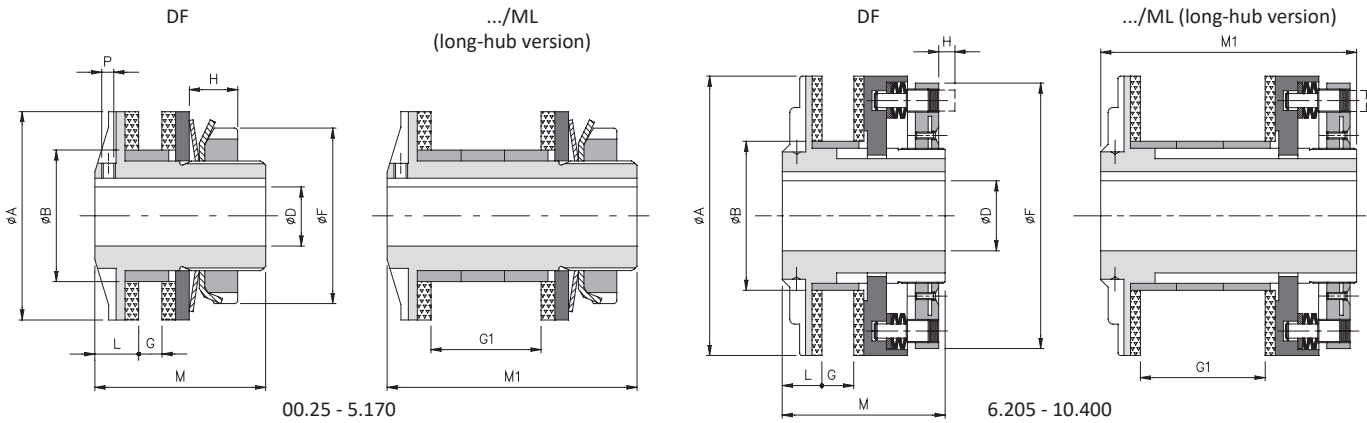

FOR TECHNICAL DATA
CONSULT THE
DEDICATED BROCHURE

DIMENSIONS

Size	A	B h7	D H7		F	G		G1 max	L	M	M1	P *
			pilot bore	max		min	max					
00.25	25	14	-	8	22	1	3	-	5	26	-	M3*
00.38	38	24	-	12	32	1	5	21	8	33	46	M3
0.50	50	36	-	20	44	1	6	26	10	35	57,5	M4
1.70	70	45	-	25	63	1	10	40	15	55	85	M6
2.90	90	60	-	38	82	3	12	46	16	60	95	M6
3.115	115	72	18	45	104	5	16	58	18	70	113	M6
4.140	140	85	24	55	130	8	19	69	20	80	136	M8
5.170	170	98	28	65	158	10	22	78	22,5	95	153,5	M8
6.205	205	120	38	80	193	18	26	90	27	110	174	-
7.240	240	145	50	100	230	18	29	99	27	116	186	-
8.300	300	175	60	120	287	21	33	113	29	123	203	-
9.340	340	205	60	130	325	23	33	113	41	158	238	-
10.400	400	230	60	140	388	23	35	119	46	167	251	-

TECHNICAL DETAILS

Size	Torque [Nm]				Inertia [10 ³ kgm ²]	Max. speed [Rpm]	Weight [Kg]	
	T0	T1	T2	T3			DF	.../ML
00.25	-	1 - 8	2 - 12	2 - 20	0,003	10000	0,1	-
00.38	-	1 - 14	8 - 22	15 - 34	0,022	10000	0,2	0,3
0.50	2 - 12	9 - 42	17 - 70	46 - 90	0,075	7600	0,4	0,5
1.70	4 - 20	15 - 80	30 - 150	80 - 230	0,390	5450	1,1	1,4
2.90	12 - 85	55 - 160	95 - 290	175 - 450	1,167	4250	2,2	2,8
3.115	65 - 265	130 - 380	200 - 700	290 - 950	3,809	3350	3,7	4,8
4.140	-	95 - 700	200 - 1300	280 - 1650	9,982	2750	6,6	8,5
5.170	-	100 - 950	600 - 1900	800 - 2800	23,943	2250	10,9	13,5
6.205	300 - 1200	500 - 2400	1000 - 4800	-	75,088	1900	20,1	24,5
7.240	500 - 2000	1000 - 4000	2000 - 8000	-	152,946	1600	30,9	37,8
8.300	800 - 3500	1500 - 7000	3000 - 14000	-	380,357	1300	49,1	60,8
9.340	1000 - 4500	2000 - 9000	4000 - 18000	-	869,290	1200	85,5	102,5
10.400	1500 - 5000	3000 - 11000	5000 - 23000	-	1830,092	1000	124,5	147,7

▲ On request

NOTES

- P *: On the size 00.25 the grubscrew is located on the nut side, not on the flange side.
- Weights are relevant to the torque limiter with pilot bore (DF), inertias refer to the maximum diameter for finished bore.

.../SI - intervention signaling version: technical data



- ⊙ Electromechanical overload signaling.
- ⊙ Automatic re-engaging after transmission reset.
- ⊙ Assembly with helical springs possible: .../SI/CM.
- ⊙ Available with a longer shaft for assembly with transmission elements of large size: .../SI/ML.
- ⊙ Available with friction rings with different performances for specific needs.
- ⊙ Torque range: 3 – 23 kNm; max. bore: $\varnothing 140$ mm.

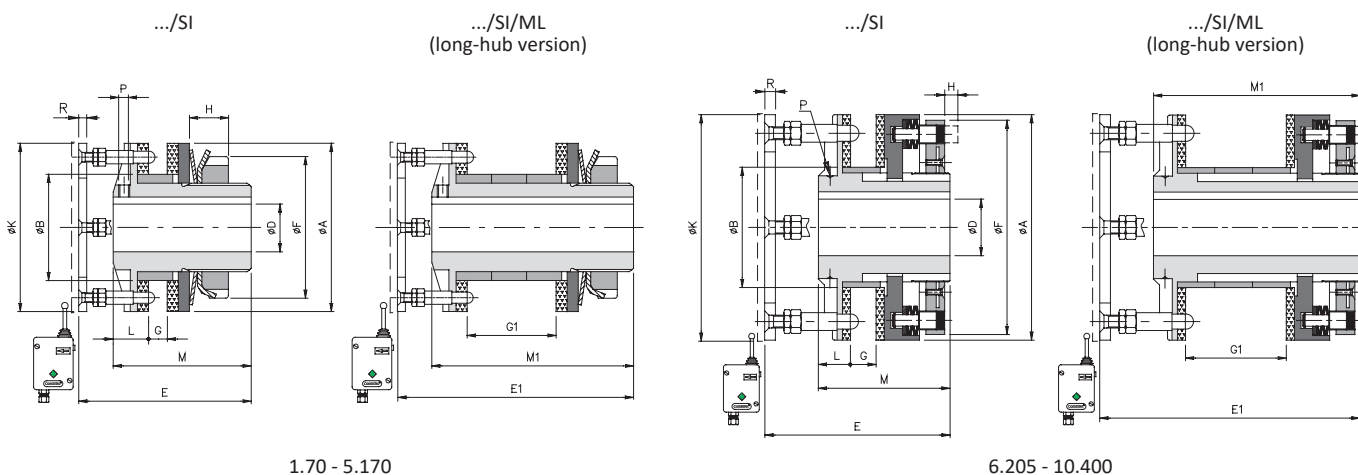

DIMENSIONS

Size	A	B h7	D H7		E	E1	F	G		G1 max	K	L	M	M1	R
			pilot bore	max				min	max						
1.70	70	45	-	25	75	105	63	5	10	40	70	15	55	85	3
2.90	90	60	-	38	80	114	82	7	12	46	90	16	60	95	3
3.115	115	72	18	45	89	131	104	9	16	58	115	18	70	113	4
4.140	140	85	24	55	97	153	130	13	19	69	140	20	80	136	4
5.170	170	98	28	65	113	172	158	15	22	78	170	22,5	95	153,5	4
6.205	205	120	38	80	124	188	193	18	26	90	205	27	110	174	4
7.240	240	145	50	100	132	202	230	18	29	99	240	27	116	186	6
8.300	300	175	60	120	137	217	287	21	33	113	300	29	123	203	6
9.340	340	205	60	130	172	252	325	23	33	113	340	41	158	238	6
10.400	400	230	60	140	176	260	388	23	35	119	400	46	167	251	6

TECHNICAL DETAILS

Size	Torque [Nm]				Inertia [10 ⁻³ kgm ²]	Max speed [Rpm]	Weight [kg]	
	T0	T1	T2	T3			DF/SI	.../ML
1.70	4 – 20	15 – 80	30 – 150	80 – 230	0,393	5450	1,4	1,7
2.90	12 – 85	55 – 160	95 – 290	175 – 450	1,178	4250	2,7	3,3
3.115	65 – 265	130 – 380	200 – 700	290 – 950	3,847	3350	4,9	6
4.140	-	95 – 700	200 - 1300	280 – 1650	10,081	2750	7,8	9,7
5.170	-	100 - 950	600 - 1900	800 - 2800	24,182	2250	12,9	15,5
6.205	300 - 1200	500 - 2400	1000 - 4800	-	75,834	1900	20,9	25,2
7.240	500 - 2000	1000 - 4000	2000 - 8000	-	154,475	1600	32,2	39,1
8.300	800 - 3500	1500 - 7000	3000 - 14000	-	384,161	1300	50,6	62,3
9.340	1000 - 4500	2000 - 9000	4000 - 18000	-	877,882	1200	88	105
10.400	1500 - 5000	3000 - 11000	5000 - 23000	-	1848,432	1000	128,8	152

NOTES

▲ On request

- Weights are relevant to the torque limiter with pilot bore (DF/SI), inertias refer to the torque limiter (DF) hole max.
- Microswitches EM1 or EM2 and inductive sensor PRX see page 73

.../TAC - version with chain coupling: technical data

- Simple and compact solution for transmission with in-line shafts.
- Protection in both rotation directions.
- Possibility of different types of friction discs for specific applications.
- Version with coil springs for precise and fine adjustment of the torque: .../CM/TAC.
- Available with radial ring statically balanced: .../GR.
- Torque range from 1 to 23 KNm; max. bore $\phi 160$ mm.

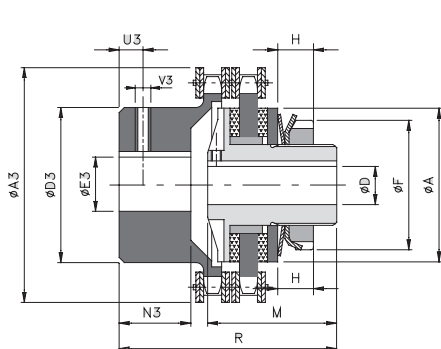

00.25 - 5.170

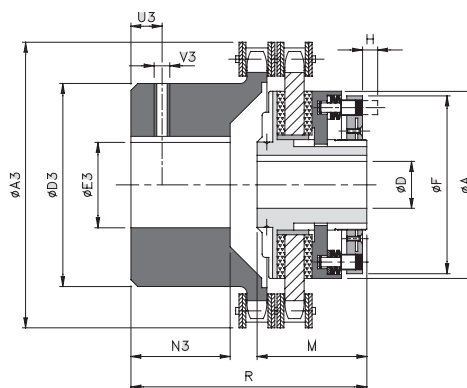

6.205 - 10.400

DIMENSIONS

Size	A	D H7		F	M	R	A3	D3	E3 H7		N3	U3	V3
		pilot bore	max						pilot bore	max			
00.25	25	-	8	22	26	39	45	23	8	12	9	4	M3
00.38	38	-	12	32	33	58	57	37	10	20	20	5	M3
0.50	50	-	20	44	35	58	75	50	12	28	19	8	M4
1.70	70	-	25	63	55	87	101	70	16	38	29	12	M6
2.90	90	-	38	82	60	102	126	89	20	55	38	12	M6
3.115	115	18	45	104	70	131	159	110	20	70	56,5	15	M8
4.140	140	24	55	130	80	145	184	130	28	80	59,5	15	M8
5.170	170	28	65	158	95	189	215	130	30	80	88	15	M8
6.205	205	38	80	193	110	218	291	150	38	90	103	25	M10
7.240	240	50	100	230	116	245	310	170	50	110	124	25	M10
8.300	300	60	120	287	123	284	374	200	50	140	147	30	M12
9.340	340	60	130	325	158	329	423	210	60	150	165	30	M12
10.400	400	60	140	388	167	364	471	240	60	160	191	30	M16

TECHNICAL DETAILS

Size	Torque [Nm]				Angular α [°]	Misalignment		Max speed [Rpm]	Weight [kg]
	T0	T1	T2	T3		Axial X [mm]	Radial K [mm]		
00.25	-	1 - 8	2 - 12	2 - 20	2°	1,50	0,20	5000	0,2
00.38	-	1 - 14	8 - 22	15 - 34		1,50	0,20	5000	0,6
0.50	2 - 12	9 - 42	17 - 70	46 - 90		1,50	0,20	3800	1,1
1.70	4 - 20	17 - 60	34 - 120	80 - 230		2,40	0,25	2800	2,8
2.90	12 - 85	55 - 160	95 - 290	175 - 450		3,20	0,30	2200	5,9
3.115	65 - 265	130 - 380	200 - 700	290 - 950		4,50	0,35	1800	11,1
4.140	-	95 - 700	200 - 1300	280 - 1650		4,80	0,40	1500	20,3
5.170	-	100 - 950	600 - 1900	800 - 2800		4,80	0,40	1300	31
6.205	300 - 1200	500 - 2400	1000 - 4800	-		6,30	0,50	1000	54,6
7.240	500 - 2000	1000 - 4000	2000 - 8000	-		6,30	0,50	900	76,7
8.300	800 - 3500	1500 - 7000	3000 - 14000	-		6,80	0,55	700	125,5
9.340	1000 - 4500	2000 - 9000	4000 - 18000	-		6,80	0,55	600	180
10.400	1500 - 5000	3000 - 11000	5000 - 23000	-	6,80	0,55	550	260	

▲ On request

NOTES

- Data is relevant to the whole group (DF/TAC).
- Weights are relevant to the whole group with pilot bore (DF/TAC).

... + GAS - model with jaw coupling: technical data

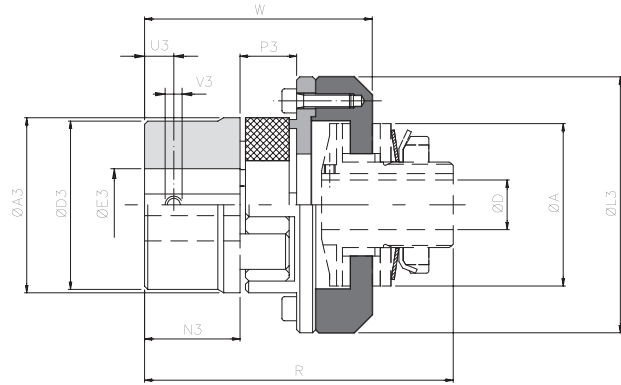

DIMENSIONS AND TECHNICAL DETAILS

DF	Size		Torque [Nm]		A3	E3 H7 max	L3	N3	P3	U3	V3	A	D H7		R	W	Misalignments *			Max speed [Rpm]	Weight [Kg]
	GAS		Nom	Max									pilot bore	max			Angular α [°]	Axial X [mm]	Radial K [mm]		
	Std	▲ Min																			
00.25	01 (14)	-	12,5	25	30	16	43	11	12	5	M4	25	-	8	56	37,5	0° 54'	-0,5/+1	0,09	10000	0,2
00.38	00 (19)	-	17	34	40	25	58	25	16	10	M5	38	-	12	84,5	64	1° 18'	-0,5/+1,2	0,20	10000	0,4
0.50	0 (24)	-	60	120	55	35	74	30	18	10	M5	50	-	20	94	74,5	1° 18'	-0,5/+1,4	0,22	7600	0,8
1.70	2 (38)	1 (28)	325	650	80	48	107	45	24	15	M8	70	-	25	135	104	1° 18'	-0,7/+1,8	0,28	5450	3,3
2.90	3 (42)	2 (38)	450	900	95	55	132	50	26	20	M8	90	-	38	148,5	115,5	1° 18'	-1/+2	0,32	4250	5,4
3.115	5 (55)	4 (48)	685	1370	120	74	164	65	30	20	M10	115	18	45	181,5	143,5	1° 18'	-1/+2,2	0,38	3350	10,3
4.140	7 (75)	6 (65)	1465	2930	160	95	208	85	40	25	M10	140	24	55	224	181	1° 18'	-1,5/+3	0,48	2750	21,1
5.170	8 (90)	7 (75)	3600	7200	200	110	246	100	45	30	M12	170	28	65	260	207,5	1° 18'	-1,5/+3,4	0,50	2250	36,3
▲ 6.205	9 (100)	-	4900	9800	225	120	285	110	50	30	M12	205	38	80	295	236	1° 18'	-1,5/+3,8	0,52	1900	-
▲ 7.240	10 (110)	-	7000	14000	255	130	330	120	55	33	M16	240	50	100	317	255	1° 18'	-2/+4,2	0,55	1600	-

... + GEC - model with compact elastic coupling: technical data

▲ On request

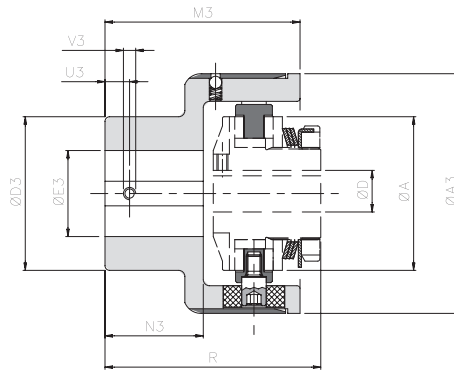

DIMENSIONS AND TECHNICAL DETAILS

DF	Size		Torque [Nm]		A3	D3	E3 H7		M3	N3	U3	V3	A	D H7		R	Misalignments			Max speed [Rpm]	Weight [Kg]
	GEC	Nom	Max	Grz			Max	pilot bore						max	Angular α [°]		Axial X [mm]	Radial K [mm]			
00.38	00	35	50	63	42	-	28	60,5	29	8	M4	25	-	12	58	1°	$\pm 0,7$	0,5	6000	0,8	
0.50	0	70	110	78	50	-	35	63,5	32	10	M5	50	-	20	70	1°	$\pm 0,7$	0,5	5500	1,4	
1.70	1	280	420	108	70	-	48	89	49	12	M6	70	-	25	106	0° 48'	$\pm 0,7$	0,5	5000	4,2	
2.90	2	570	860	130	80	-	55	111	65	15	M8	90	-	38	128	0° 36'	$\pm 0,7$	0,6	4250	7,4	
3.115	3	980	1500	161	100	-	68	140	85	15	M8	115	18	45	158	0° 30'	$\pm 0,8$	0,6	3350	13,4	
4.140	4	2340	3600	206	120	20	80	168	105	20	M10	140	24	55	189,5	0° 24'	$\pm 0,8$	0,6	2750	24,1	
5.170	5	3880	5800	239	135	30	90	201	130	20	M10	170	28	65	229,5	0° 24'	$\pm 0,8$	0,6	2250	37,9	
▲ 6.205	6	15000	20000	315	215	40	150	260	165	25	M12	205	38	80	290,5	0° 24'	$\pm 0,8$	0,6	1900	86,8	
▲ 7.240	7	15000	17500	360	240	40	165	310	205	25	M12	240	50	100	341,5	0° 24'	$\pm 0,8$	0,6	1500	160,5	

▲ On request

NOTES

- ... + GAS (torque and misalignments)*: data relates to red elastomeric element 98Sh-A.
- Data is relevant only to application (.../GAS - .../GEC), for torque limiter data see on page 9
- Weights are relevant only to the coupling application with pilot bore version (.../GAS - .../GEC).

DF - friction torque limiter: additional information

OTHER COUPLING ON REQUEST

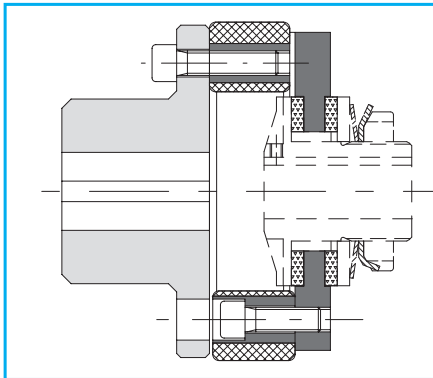

Model DF suitable for connections GF to coaxial shafts capable of recovering high misalignments.

VERSIONS ON REQUEST

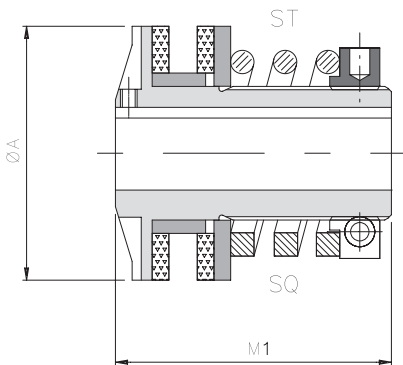

.../CM: minimum torque version (with GR ring nut)

Helical springs execution, for a wider torque range and consequently a finer adjustment on calibration is possible.

Size	Torque [Nm]		A	M1
	spring ST	spring SQ		
0.50	4,5 - 11	-	50	57,5
1.70	2 - 34	2 - 60	70	85
2.90	5 - 56	3 - 70	90	95
3.115	10 - 130	25 - 160	115	113

STAINLESS STEEL discs

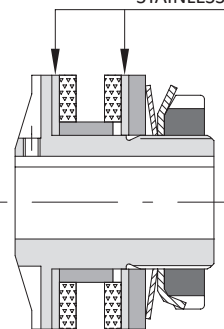

.../EA: rust resistant

Rust resistant execution, with stainless steel rings, galvanized for application in wet environments.

For size 00.38 - 3,115 DF

.../GR: model with radial ring

Ring with radial locking statically balanced alternative to the grooved nut GT standard. Available from size 00.38 to 5.170.

For size 00.38 - 5,170 DF

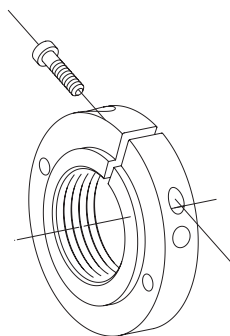

GT/DR KIT: kit for double registration matching to the nut with notches GT

Torque adjustment system with double registration (with flange and hex head screws) for high sensitivity and precision calibration, also with belleville washers.

For size 1.70 - 5,170 DF

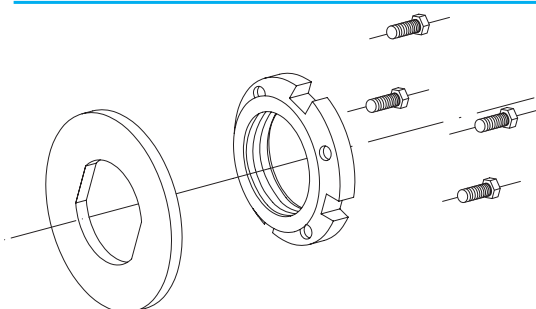

DF - friction torque limiter: additional information

PLATE WHEELS

The driving part selected (plate wheels, pulleys, gears, and so on) to be incorporated into the friction torque limiter, must adhere to predetermined characteristics (ex. the surface in contact to the friction rings with roughness $Ra=0,8 : 1,6$) to ensure good performance. In the table below, there are standard plate wheels in CominTec's production (supplied already grounded) which can be assembled on the torque limiter; **and the minimum chain passage "V"** (see picture 3), necessary for the correct sizing of the plate wheel to avoid contact between the chain and outside diameter of the limiter. It is possible to assemble various types of plate wheels, but the surfaces must be machined, and the chain passage cannot be smaller than this value. Another aspect to take into consideration to ensure the dimension of the assembly is correct, is the element thickness and its relevant bush "N" (see picture 1). We suggest to obtain a quote "N" equal to $[S + G + W]$. Comparing "N" value obtained, to the N_{std} indicated on the table, which corresponds to the standard length of the bushes, you can have: "N" < " N_{std} " (picture 1 - ex.A) → reduce the bush width to quote "N".
"N" > " N_{std} " (picture 2 - ex.B) → machine the driving part at a diameter of "A+1" and a depth equal to "x" ($N - N_{std}$).

Example "A" (see picture 1)
1.70 with plate wheel #7
G = 7 mm
S = 4 mm
N = S+G+W = 4 + 7 + 1,5 = 12,5
 $N_{std} = 15$
Reduce the bush width to 12 mm.

Example "B" (see picture 2)
1.70 with plate wheel #13
G = 13 mm
S = 4 mm
N = S+G+W = 4 + 13 + 1,5 = 18,5
 $N_{std} = 15$
Machine $\varnothing 71$ with depth (value "x" = 18-15 = 3)

where:

p = pitch [in]
G = thickness of the ground element
z = teeth number
dp = pitch diameter
S = thickness of the friction ring
 N_{std} = thickness of the standard bush
N = thickness of the calculated bush (S+G+W)
A = outside diameter of the torque limiter
V = inside diameter of the chain
x = depth of the machining ($N - N_{std}$)
W = min useful assembly for 2° friction ring
= 1 (00,25 ÷ 0,50 DF)
= 1,5 (1,70 ÷ 7,240 DF)
= 2 (8,300 ÷ 10,400 DF)

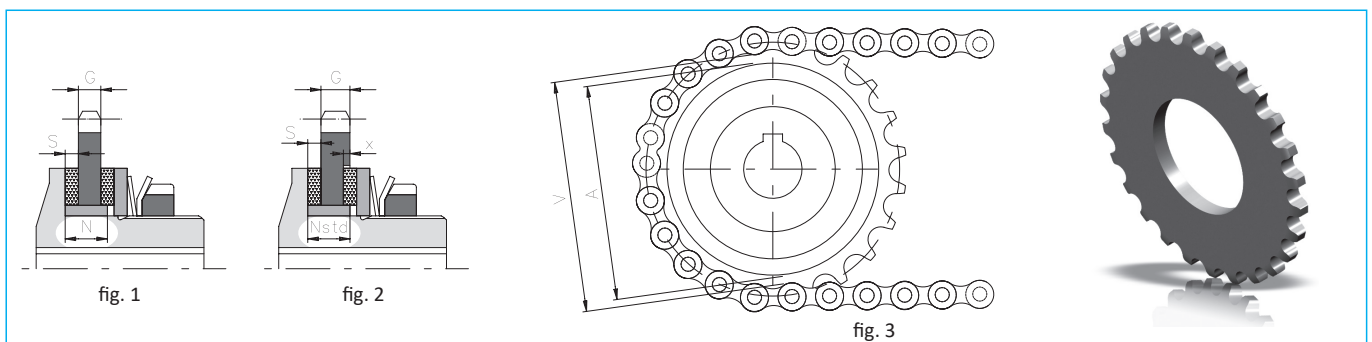

Size	P [in]		G [mm]	z	dp [mm]	S [mm]	N_{std} [mm]	A [mm]	V [mm]	W	Code for single plate wheel		
	DF e DSF/TF/AP	DF/SI e DSF/TF/AP/SI									EDF/F		
00.25	3/8"	06 B	5,1	12	36,80	2	5,5	25	28	1	580419851P05	-	-
00.38	3/8"	06 B	5,1	16	48,82	2,5	8	38	41	1	580406961P05	-	580406961P05
0.50	3/8"	06 B	5,1	20	60,89	3	10	50	53	1	580406460P05	-	580406460P05
			5,1	22	66,93						580406560P05	-	-
1.70	1/2" x 5/16"	08 B	7,0	22	89,24	4	15	70	73	1,5	580403753P05	580401200P20	580403753P05
	5/8"	10 B	8,9	19	96,45						580404200P05	-	-
2.90	1/2" x 5/16"	08 B	7,0	26	105,36	4	17	90	94	1,5	580404700P05	-	-
	3/4"	12 B	10,9	18	109,71						580440100P05	580442100P20	580440151P05
3.115	3/4"	12 B	10,9	23	139,9	4	21	115	119	1,5	580404900P05	-	-
	1"	16 B	16,0	17	138,22						580440251P05	580442200P20	580440251P05
4.140	3/4"	12 B	10,9	28	170,13	5	25	140	144	1,5	580405500P05	-	-
	1"	16 B	16,0	20	162,38						580440300P05	580442300P20	580440351P05
5.170	1"	16 B	16,0	24	194,59	5	28	170	175	1,5	580440400P05	580442400P20	-
	1" 1/4	20 B	18,3	20	202,98						580417200P05	-	-
▲ 6.205	1" 1/4	20 B	18,3	26	263,40	5	32	205	210	1,5	580406200P05	580407600P20	-
▲ 7.240	1" 1/4	20 B	18,3	28	283,56	5	35	240	245	1,5	580406300P05	580407700P20	-
▲ 8.300	1" 1/2	24 B	23,8	28	340,27	6	40	300	306	2	580407000P05	580407300P20	-
▲ 9.340	1" 1/2	24 B	23,8	32	388,69	6	40	340	355	2	580407100P05	580407400P20	-
▲ 10.400	1" 1/2	24 B	23,8	36	437,16	6	42	400	403	2	580407200P05	580407500P20	-

▲ A richiesta

DF - friction torque limiter: additional information

SENSOR CONNECTION EXAMPLE

To maximize the lifetime of the friction rings and maintain the performance of the limiter, you should promptly stop the drive as soon as the first slip occurs. This is possible using the model DF / SI combined with a micro-switch (model EM1 or EM2) or an inductive sensor (model PRX), see page 73.

If this is not possible, however, we suggest the use of an inductive sensor connected to a tachometer or frequency inverter in order to reveal the possible speed change of a metallic mass connected to the organ of transmission, as shown in the example below.

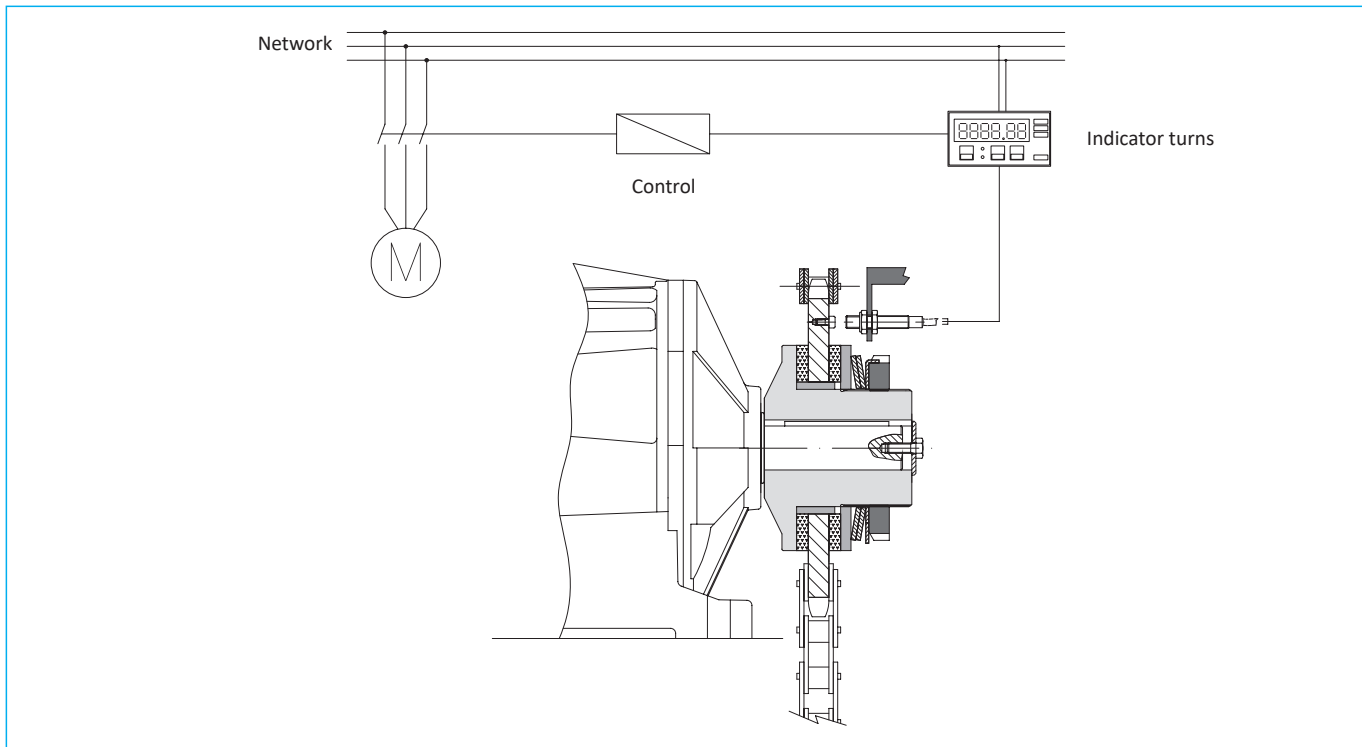

ORDER EXAMPLE

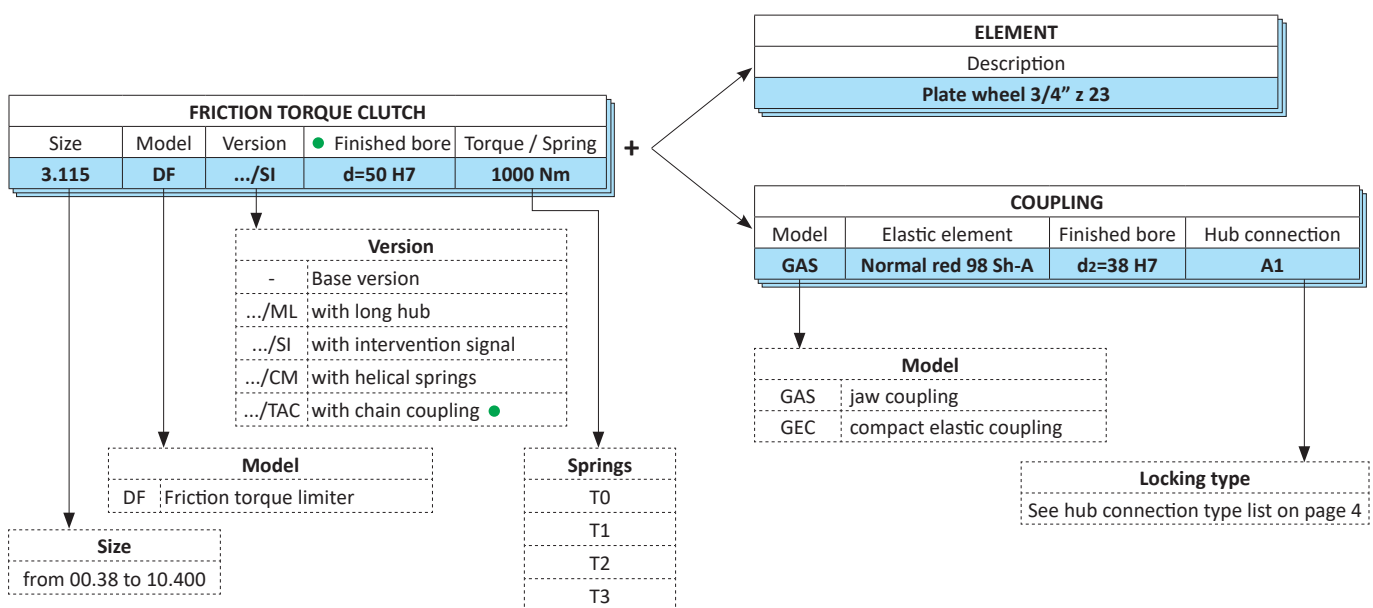

- If the version of DF/TAC state both finished bores (on the limiter and pinion TAC).

Size	Model	Version	Bore T.L.	Bore coupling	Torque / Spring
3.115	DF	.../TAC	d1=50 H7	d2=60 H7	1000 Nm